

Montážní návod

(Montážny návod, Fitting instruction, Montageanleitung,
Istruzioni di montaggio, Monteringshandledning,
Asennusohje, Instruction de montage,
Montegehandleiding, Инструкция по установке)



Tažné zařízení Opel Grandland X 06/2017->

Ťažné zariadenie
Towbars
Trekhaak
Anhängerkupplung de
Dispositif d'attelage
Equipo de remolque
Sprzęt holowniczy
Hinauslaitteet
Буксирное оборудование



výrobce / dodavatel
SVC Group s.r.o.

Odkaz na produkt:

<https://www.svcgroup.cz/tazne-zarizeni-sro-uby-pevny-skoda-rapid-monte-carlo-10-2012-2018-p7283-v960>



www.svcgroup.cz

2016 | 25 let



SVC GROUP s.r.o.

TYP
VTZ 001-459
VTZ 002-459
VTZ 003-459

Průmyslová zóna 179
547 01 Náchod
Česká Republika

www.svcgroup.cz



OPEL GRANDLAND X



06/2017 ->

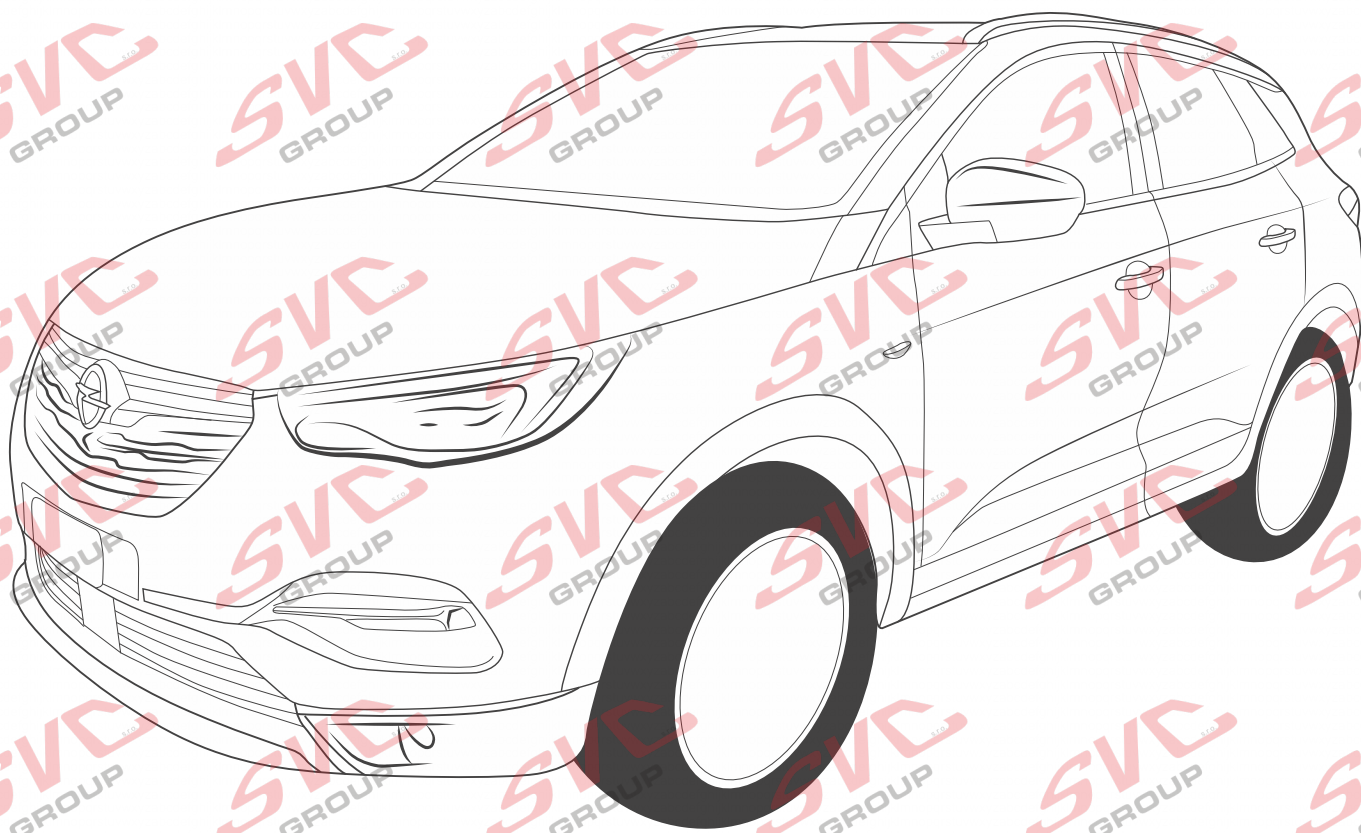

CZ Montážní instrukce

SK Montážne inštrukcie

EN Mounting instructions

DE Montageanleitung

HU Szerelési útmutató

FR Instructions de montage

IT Istruzioni di montaggio

PL Instrukcja montażu

ES Instrucciones de montaje

NL Montage-instructie

FIN Asennusohjeet

NOR Monteringsanvisning

SV Monteringsanvisningar

RU Инструкция по монтажу

SVC GROUP © 4014

e-mail: scv@scvgroup.cz Tel.: +420 491421021 +420 491421022 mob.: +420 603360607



VTZ



VTZ 001-459



VTZ 002-459



VTZ 003-459

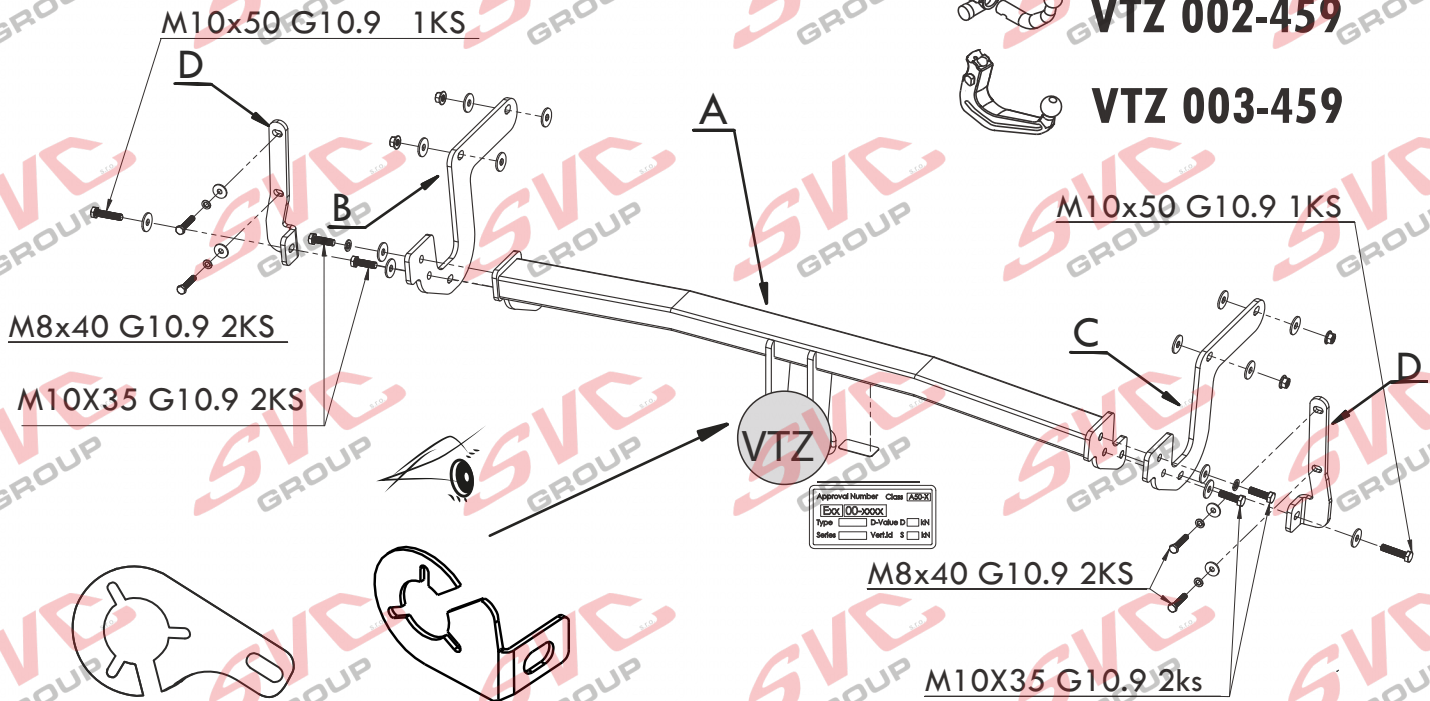

Držák zásuvky použijte, dle modelu a výbavy vozu
 u některých vozidel není možné využít sklápěcí zásuvku SKL
 U těchto modelu je následně potřeba použít běžný držák auto zásuvky pod šroub
 Oba držáky jsou součástí dodávky

	A	x1
	B	x1
	C	x1
	D	x1
	E	x1
Dlouhé		1+1

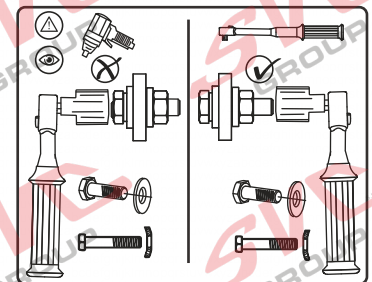

	M10x50	2ks
	M10x35	4ks
	M8x40	4ks
	Ø10	14ks
	Ø8	4ks
	Ø10	2ks
	Ø8	4ks
	M10	8ks



Opel Grandland X



06/2017 ->

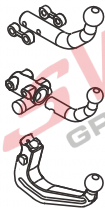

VTZ 001-459

VTZ 002-459

VTZ 003-459

20,5

kg

31,5

kg

23,5

kg



1,5 h



06/2016 ->

100

kg

2 100

kg

D= 10,46

kN

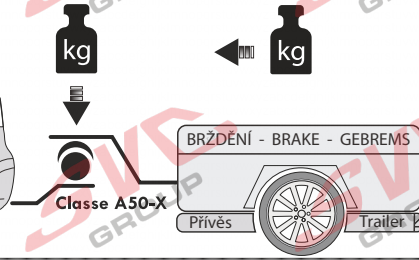
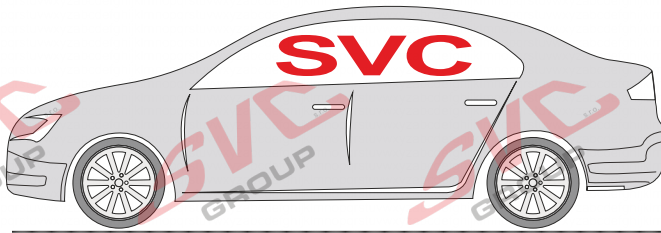

Diagram showing the location of the brake system components on the car. A checkmark indicates that the components are visible, while a crossed-out checkmark indicates they are not visible. A trash can icon is also present.

Není vidět
 Je vidět

Diagram showing the location of the brake system components on the car. A checkmark indicates that the components are visible, while a crossed-out checkmark indicates they are not visible.

Není vidět
 Je vidět

Pevnost	8,8	10,9	12,9
M6	9,7	14,3	16,1
M8	24,5	35,9	42,0
M10	48,4	71,0	83,0
M12	84,0	123,0	144,0
M14	133,0	196,0	229,0
M16	137,0	307,0	359,0

Nm

Homologace - registrační certifikát

E27-55R-01-0417

EHC R-55
ES 94/20

Není vidět
 Je vidět

- CZ Informace k provozu / homologaci
- SK Informácie na prevádzku / homologáciu
- EN Operating / homologation information
- DE Betriebs- / Zulassungsinformationen
- HU Üzemeltetési / homologációs információk
- FR Informations d'exploitation / homologation
- IT Informazioni sull'operazione / omologazione
- NL Monteringsanvisningar
- ES Instrucciones de montaje
- FIN Montage-instructie
- SV Asennusohjeet
- NOR Drifts- / homologasjonsinformasjon
- PL Informacje dotyczące pracy / homologacji
- RU Информация о работе / омологации



EHC R-55
ES 94/20

CZ Informace k provozu / homologaci

E-2

Výrobek je schválen dle homologací EU 94/20 EHK-55 R pro prodej ve státech EU. Pozorně si nastudujte montážní návod a všechna doporučení, dále dodržujte případná nařízení pro provoz jednotlivých států EU. Všeobecné montážní, homologační, provozní pokyny vztahující se k montáži, registraci a záruce výrobku, naleznete na našem webu www.svcgroup.cz

Pro rychlejší přístup k těmto informacím si naskenujte, přiložený QR kód.

Součástí dodávky tažného zařízení je dodán TYPOVÝ LIST. Tento typový list slouží pro zapsání výrobku do technického průkazu vozidla, druhá strana dokumentu obsahuje základní informace a pokyny.

SK Informácie na prevádzku / homologáciu

Výrobok je schválený podľa homologácií EÚ 94/20 EHK-55 R pre predaj v štátoch EÚ. Pozorne si nashudujte montážny návod a všetky odporúčania, ďalej dodržujte prípadné nariadenia pre prevádzku jednotlivých štátov EÚ. Všeobecné montážne, homologačné, prevádzkové pokyny vztahujúce sa na montáž, registráciu a záruku výrobku, nájdete na našom webe www.svcgroup.cz.

Pre rýchlejší prístup k týmto informáciám si naskenujte priložený QR kód.

Súčasťou dodávky ťažného zariadenia je dodaný TYPOVÝ LIST. Tento typový list slúži na zapísanie výrobku do technického preukazu vozidla, druhá strana dokumentu obsahuje základné informácie a pokyny.

EN Operating / homologation information

The product is approved according to EU 94/20 EHK-55 R homologations for the sale in EU countries. Please read the installation instructions and all the recommendations carefully and follow the applicable regulations for the operation in individual EU states. General assembly, homologation, operating instructions related to registration and product warranty are available at our website - www.svcgroup.cz

For a quicker access to this information scan the attached QR code.

Each delivery of the tow bar includes TYPE CERTIFICATE. This type certificate is for registering the product in the vehicle's certificate of roadworthiness, the other side of the document brings basic information and instructions.

DE Betriebs / Zulassungsinformationen

Das Produkt ist gemäß der Homologation EU 94/20 EHK-55 R für den Verkauf in den EU-Ländern zugelassen. Lesen Sie sorgfältig die Montageanleitung und alle Empfehlungen durch, halten Sie ferner etwaige Betriebsverordnungen einzelner EU-Länder ein. Etwaige Montage-, Zulassungs- und Betriebsanweisungen hinsichtlich der Montage, Anmeldung und Garantie des Produkts finden Sie auf unserer Website www.svcgroup.cz

Für schnelleren Zugriff auf diese Informationen scannen Sie den anliegenden QR-Code ein.

Lieferungsbestandteil der Zugeinrichtung ist das mitgelieferte TYPENBLATT. Dieses Typenblatt dient zum Eintragen des Produkts in den Fahrzeugbrief des Fahrzeugs, die andere Seite des Dokuments enthält Basisinformationen und Anweisungen.

HU Üzemeltetési / homologációs információk

A jelen termék az Európai Parlament és Tanács 94/20/EK és az Európai Gazdasági Bizottság 55 R számú rendelet szerinti homologia besorolások alapján lett az EU közösségi országokban történő értékesítések számára engedélyezve. Figyelmesen olvassa el a beszerelési útmutatót és valamennyi javaslatot, illetve az egyes EU közösségi országok hatályos vonatkozó közlekedésrendészeti előírásait. A beszerelés, homologia besorolásra, regisztrálásra és a garancianyújtásra vonatkozó általános szerelési és üzemeltetési utasítások a társaságunk honlapján www.svcgroup.cz tekinthetők meg.

A gyorsabb hozzáférés érdekében skennelje be a mellékelt QR kódot.

A vonószerkezet szállítmány részét képezi a TÍPUSLAP is. A csatolt típuslap az adott termék a gépjármű forgalmi engedélyébe való bejegyzéséhez van rendeltetve, és a hátulján pedig az alapinformációk és utasítások vannak feltüntetve.

FR Informations d'exploitation / homologation

En vertu de l'homologation UE 94/20 ECC-55 R, ce produit a été homologué pour pouvoir être vendu dans les états de l'Union européenne. Nous vous recommandons de lire attentivement la notice de montage et toutes les autres recommandations. Il convient également de respecter les éventuels règlements relatifs à l'utilisation qui sont en vigueur dans les différents états de l'Union européenne. Les consignes générales de montage, les consignes relatives à l'homologation, les consignes d'emploi se rapportant au montage, à l'enregistrement et à la garantie qui couvrent le produit sont disponibles sur notre site Internet www.svcgroup.cz.

Pour pouvoir accéder plus rapidement à ces informations, nous vous recommandons de scanner le code QR ci-joint.

Le dispositif d'attelage est fourni accompagné d'une FICHE PRODUIT qui vous servira lors de l'enregistrement du produit dans la carte grise du véhicule. Au verso de ce document, vous trouverez des informations et des consignes importantes.

IT Informazioni sull'operazione / omologazione

Il prodotto è approvato secondo le omologazioni dell'UE 94/20 EHK-55 R per essere commercializzato nei paesi dell'UE. Leggere attentamente le istruzioni di montaggio e tutte le raccomandazioni. Rispettare anche eventuali prescrizioni per l'uso dei singoli paesi dell'UE. Tutte le istruzioni di montaggio, omologazione e esercizio relative al montaggio, registrazione e garanzia del prodotto sono da trovare nel nostro sito www.svcgroup.cz

Per un accesso migliore a queste informazioni scannare il codice QR allegato.

Una parte della fornitura del dispositivo di traino è la SCHEDA TIPO. Questa scheda tipo serve a registrare il prodotto nella carta di circolazione del veicolo; alla seconda pagina del documento sono riportate informazioni base e istruzioni.

SVC GROUP ©-4014

SVC GROUP s.r.o.

Průmyslová zóna - 179
547 01 Náchod-ČR

www.svcgroup.cz
e-mail: svc@svcgroup.cz

Tel.: +420 491 421 021
+420 491 421 022
mob.: +420 603 360 607



EHC R-55
ES 94/20

NL Monteringsanvisningar

Het product is goedgekeurd volgens de Europese norm 94/20/EG en UNECE 55R voor verkoop binnen de EU. Gelieve nauwkeurig de montagehandleiding en aanbevelingen door te nemen en eventuele verordeningen voor het gebruik van afzonderlijke EU-landen in acht te nemen. De algemene montage-, goedkeurings- en gebruiksinstructies met betrekking tot de montage, registratie en garantie van het product vindt u op onze website www.svcgroup.cz

Scan voor een snellere toegang tot deze informatie de QR-code.

Bij de trekhaak wordt een datablad meegeleverd. Dit datablad dient voor de inschrijving van het product in het kentekenbewijs van de auto; de tweede pagina van het document bevat basisinformatie en instructies.

E-3

ES Instrucciones de montaje

El producto fue aprobado según las homologaciones de la directiva 94/20/CE del Parlamento Europeo y del Consejo -Reglamento 55, relativo a la venta en los países de la UE. Lea con atención el manual de montaje y todas las recomendaciones, respete también instrucciones del Código de Tránsito de los diferentes países de la UE, si procede. Las instrucciones generales de montaje, homologación y funcionamiento que se reeren al montaje, registro y garantía del producto se encuentran en nuestro web www.svcgroup.cz

Para acceder más rápidamente a las informaciones escanee y aplique el código QR.

El suministro del equipo de tiro incluye la FICHA DE TIPO. Esta cha de tipo sirve para la inscripción del producto en el documento de la Inspección Técnica de Vehículos, la segunda página del documento contiene informaciones e instrucciones básicas.

FIN Montage-instructie

Tuotteella on EU 94/20 EHK-55 R mukainen tyyppihyväksyntä EU-maissa myyntiä varten. Tutustu huolellisesti asennusohjeeseen ja kaikkiin suosituksiin, noudata myös eri EU-maiden mahdollisia maakohtaisia käyttöä koskevia asetuksia. Tuotteen asennusta, rekisteröintiä ja takuuta koskevat yleiset asennus-, hyväksyntä- ja käyttöohjeet löydät web-sivuiltamme www.svcgroup.cz

Nopeampaa näihin tietoihin pääsyä varten skannaa oheinen QR-koodi.

Vetolaitteen mukana toimitetaan TYYPIHYVÄKSYNTÄTODISTUS. Tuote voidaan merkitä ajoneuvon rekisteriotteeseen tämän tyyppihyväksyntätodistuksen mukaisesti, dokumentin toisella sivulla on perustietoja ja ohjeita.

SV Asennusohjeet

Produkten är godkänd enligt homologeringen EU 94/20 EHK-55 R för försäljning inom staterna i EU, Läs noggrant igenom monteringsanvisningarna och alla rekommendationer, följ även enskilda EU-staters eventuella bestämmelser för drift. De allmänna monterings-, homologiserings- och driftsanvisningarna gällande produktens montage, registrering och drift hittar du på vår webbsida www.svcgroup.cz

För snabbare åtkomst till den informationen skanna den medföljande QR-koden.

En del av draganordningens leverans är TYPBLADET. Detta typblad tjänar till för inskrivning av produkten i fordonets registreringsbevis, dokumentets andra sida innehåller grundläggande information och instruktioner.

NOR Drifts- / homologasjonsinformasjon

Produktet er godkjent i hht. EU-homologering 94/20 EHK-55 R for salg i EU-land. Les nøye gjennom monteringsanvisningen og alt av anbefalinger, og overhold dessuten evt. retningslinjer som måtte gjelde i de enkelte EU-landene. Generell veiledning ang. montering, homologering, samt drift som gjelder produktets montering, registrering og garanti, nner du på vårt nettsted www.svcgroup.cz

Skann den vedlagte QR-koden for raskere tilgang til denne informasjonen

TYPEBLAD følger med leveransen av trekkutstyret. Dette typebladet brukes til å registrere produktet i bilens vognkort, mens dokumentets 2. side inneholder grunnlegg ende informasjon og veiledning.

PL Informacje dotyczące pracy / homologacji

Wyrób jest zatwierdzony zgodnie z homologacją WE 94/20 EHK-55 R do sprzedaży w krajach WE. Prosimy uważnie przeczytać instrukcję montażu i wszystkie zalecenia, a następnie przestrzegać ewentualnych rozporządzeń obowiązujących w zakresie użytkowania w poszczególnych krajach WE. Ogólne zalecenia i informacje dotyczące montażu, homologacji, zaleceń eksploatacyjnych, rejestracji i gwarancji na wyrób, znajdują się na naszej stronie internetowej: www.svcgroup.cz

Aby uzyskać szybszy dostęp do tych informacji, prosimy zeskanować załączony kod QR.

Częścią dostawy tego urządzenia sprzęgającego jest zawarta w komplecie KARTA PRODUKTU. Ta karta służy do wpisania wyrobu do dowodu rejestracyjnego pojazdu, a druga strona dokumentu zawiera podstawowe informacje i zalecenia.

RU Информация о работе /омологации

На изделие выдан сертификат качества согласно EU 94/20 EHK-55 R для продажи в государствах ЕС. Внимательно изучите инструкцию по монтажу и все рекомендации, а также соблюдайте постановления по эксплуатации отдельных стран ЕС. Общие указания по монтажу, сертификации и эксплуатации, относящиеся к монтажу, регистрации и гарантии на изделие можно найти на нашем сайте www.svcgroup.cz

Для быстрого доступа к этой информации отсканируйте прилагаемый QR-код.

В комплект поставки фаркопа входит ТИПОВОЙ ЛИСТ. Этот типовой лист служит для записи изделия в паспорт транспортного средства, вторая сторона документа содержит основную информацию и указания.

SVC GROUP ©-4014

SVC GROUP s.r.o.

Průmyslová zóna - 179
547 01 Náchod-ČR

www.svcgroup.cz
e-mail: svc@svcgroup.cz

Tel.: +420 491 421 021
+420 491 421 022
mob.: +420 603 360 607



06/2017 -

CZ

Montážní návod

1. Odmontujte zadní světla a zadní nárazník.
2. Odmontujte z hliníkové výztuhy z obou stran venkovní šrouby M8 nad sebou. K nosníku namontujte pravý a levý bok tažného zařízení tak, že nasadíte nejprve velkoplošné podložky, poté bok a následně podložku a matici. (Nedotahovat)
3. K výztuze přimontujte pravou a levou příložku 4 šrouby M8. Mezi takto připravené boky namontujte hlavní nosník tažného zařízení za pomoci 6 šroubů M10. Tažné zařízení vyrovnejte a dotáhněte dle utahovacích momentů.
4. Zhotovte výřez nárazníku a poté namontujte zpět všechny díly odmontované v bodě č.1.

EN

Installation instructions

1. Remove rear lights and rear bumper.
2. Remove outer M8 screws, one above another, from both sides of the aluminium stienner. Install right and left sides of the tow bar to the beam in following way: at rst put on large-area washers, then the sides and subsequently washers and nuts (tighten only lightly).
3. Fix right and left brackets to the stienner by four M8 screws. Using six M10 screws install main beam of the tow bar between the sides prepared in previous step. Align all the parts of the tow bar and tighten them to prescribed torques.
4. Make a cut-out in the bumper and then reinstall all the parts removed within the step 1.

DE

Montageanleitung

1. Die Hecklichter und hintere Stoßstange ausbauen.
2. Von der Aluminiumstrebe die übereinander angeordneten Schrauben M8 entfernen; und zwar an beiden Seiten. Zum Träger den rechten und linken Seitenteil der Zugeinrichtung befestigen; zuerst sind die großjächigen U- Scheiben, dann der Seitenteil und dann die Scheibe und Mutter aufzusetzen. (Nicht festziehen)
3. Die rechte und linke Beilagscheibe mit 4 Schrauben M8 zur Strebe befestigen. Zwischen derartig vorbereitete Seitenteile den Hauptträger der Zugeinrichtung mithilfe von 6 Schrauben M10 befestigen. Die Zugeinrichtung ausrichten und mit den entsprechenden Momenten anziehen.
4. Einen Ausschnitt in der Stoßstange herstellen und anschließend alle im Punkt 1 ausgebauten Teile wieder einbauen.

IT

Istruzioni dimontaggio per la

1. Smontare i fanali posteriori e il paraurti posteriore.
2. Dal rinforzo in alluminio smontare le viti esterne M8 situate l'una sopra l'altra; sempre da ambedue i lati. Montare il lato destro e sinistro del dispositivo di traino al supporto inserendo dapprima le rondelle di grandi dimensioni, quindi il lato e poi la rondella e il dado. (Non serrare a fondo)
3. Montare al rinforzo la piastrina destra e sinistra usando 4 viti M8. Tra i lati preparati in questo modo montare il supporto principale del dispositivo di traino usando 6 viti M10. Allineare il dispositivo di traino e serrare con le coppie di serraggio prescritte.
4. Fare un intaglio nel paraurti e rimontare tutti i componenti smontati nel punto 1.

FR

Notice de montage

1. Démonter les feux arrière et le pare-chocs arrière.
2. Sur le renfort en aluminium, des deux côtés, retirer les vis extérieures M8 qui sont l'une au-dessus de l'autre. Placer les côtés gauche et droit du dispositif d'attelage sur la traverse en plaçant tout d'abord des rondelles extralarges, ensuite le côté du dispositif et enn une rondelle et un écrou (Ne pas serrer l'écrou).
3. Installer les rallonges gauche et droite sur le renfort et les xer à l'aide de 4 vis M8. Placer la traverse principale du dispositif d'attelage principal entre les côtés ayant été ainsi préparés et la xer à l'aide de 6 vis M10. Aligner le dispositif d'attelage et serrer ensuite les vis et écrous aux couples de serrage prescrits.
4. Eectuer une découpe dans le pare-chocs et remettre ensuite en place toutes les pièces qui ont été démontées au point 1.

SVC GROU' ☎-4014

SVC GROUP s.r.o.

Průmyslová zóna - 179
547 01 Náchod-ČRwww.svcgroup.cz
e-mail: svc@svcgroup.czTel.: +420 491421021
+420 491421022
mob.: +420 603360607



06/2017 -

FR

Notice de montage

1. Démonter les feux arrière et le pare-chocs arrière.
2. Sur le renfort en aluminium, des deux côtés, retirer les vis extérieures M8 qui sont l'une au-dessus de l'autre. Placer les côtés gauche et droit du dispositif d'attelage sur la traverse en plaçant tout d'abord des rondelles extralarges, ensuite le côté du dispositif et enfin une rondelle et un écrou (Ne pas serrer l'écrou).
3. Installer les rallonges gauche et droite sur le renfort et les serrer à l'aide de 4 vis M8. Placer la traverse principale du dispositif d'attelage principal entre les côtés ayant été ainsi préparés et la serrer à l'aide de 6 vis M10. Aligner le dispositif d'attelage et serrer ensuite les vis et écrous aux couples de serrage prescrits.
4. Effectuer une découpe dans le pare-chocs et remettre ensuite en place toutes les pièces qui ont été démontées au point 1.

RU

Инструкция по монтажу

1. Снимите задние фонари и задний бампер.
2. Выкрутите из алюминиевого усилителя с обеих сторон наружные болты М8, расположенные друг над другом. В балке сзади установите левый и правый бока фаркопа, при этом сначала вставьте увеличенные шайбы, потом бок, а затем шайбу и гайку. (Не затягивать)
3. К усилителю привинтите правую и левую накладку 4 болтами М8. Между подготовленными боками установите главную балку фаркопа с помощью 6 болтов М10. Выровняйте фаркоп и затяните в соответствии с предписанными моментами затяжки.
4. Сделайте вырез в бампере и верните на место все части, демонтированные согласно пункту 1.

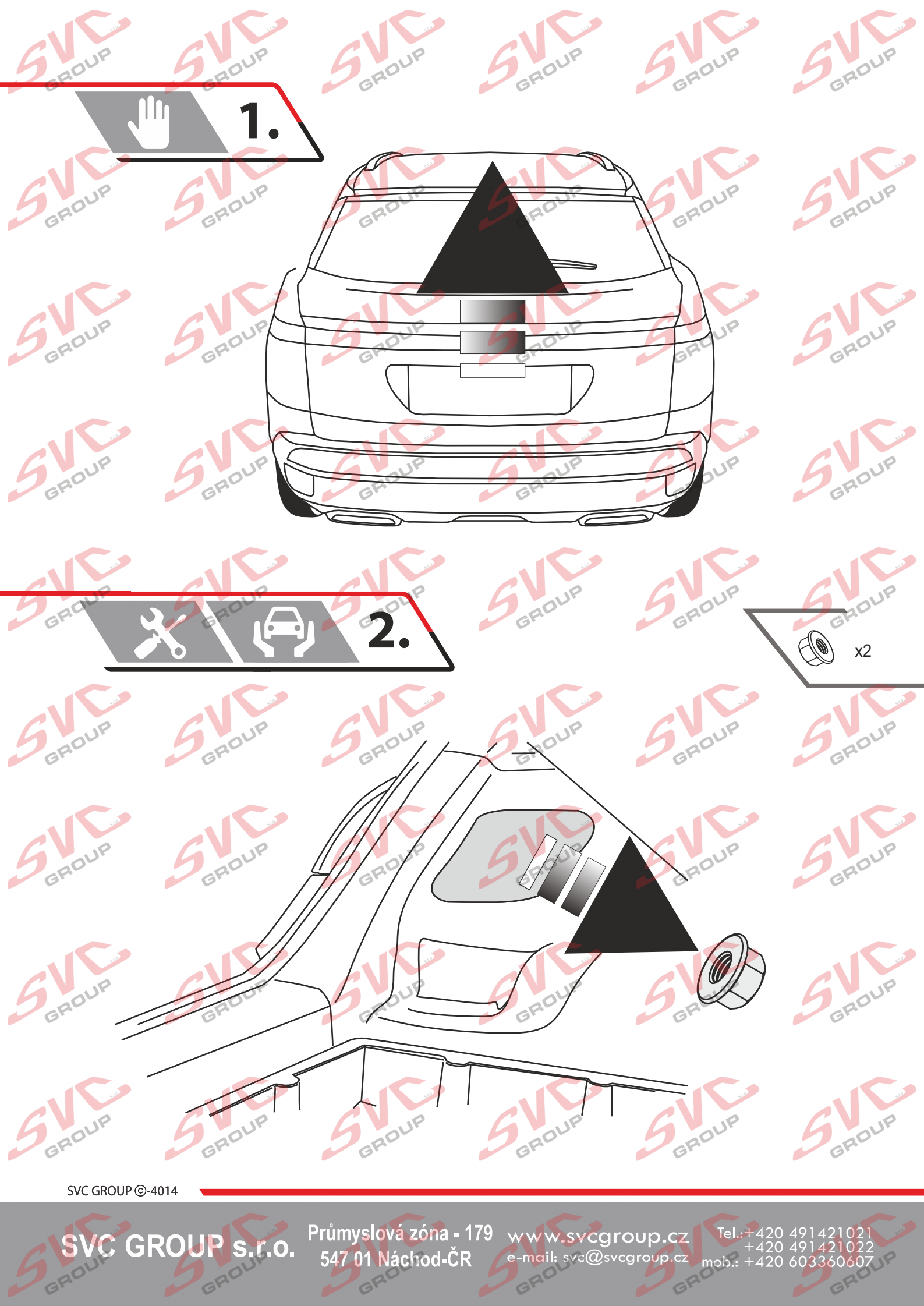

1.

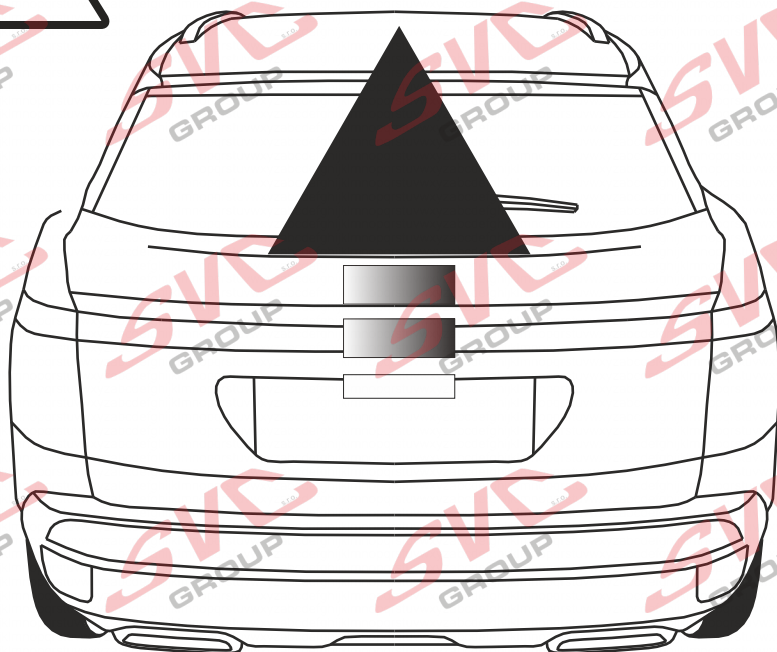

2.

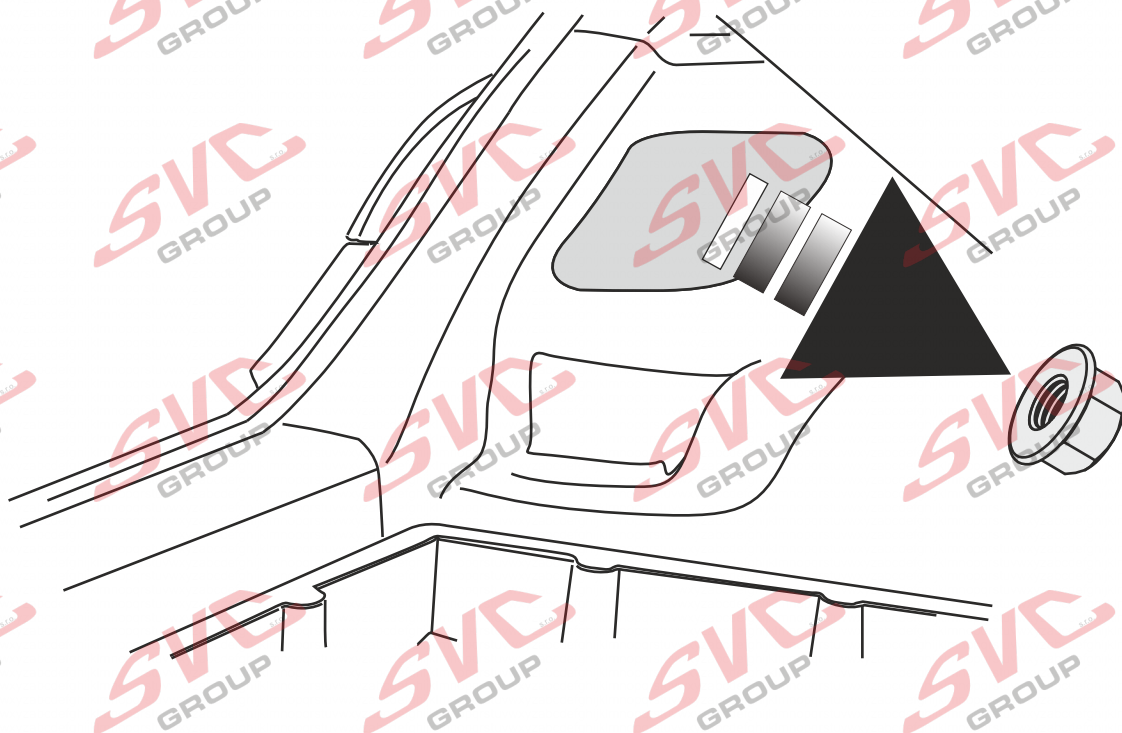
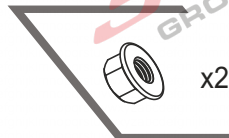

SVC GROUP ©-4014

SVC GROUP s.r.o.

Průmyslová zóna - 179
547 01 Náchod-ČR

www.svcgroup.cz
e-mail: svc@svcgroup.cz

Tel.: +420 491421021
+420 491421022
mob.: +420 603360607



3.

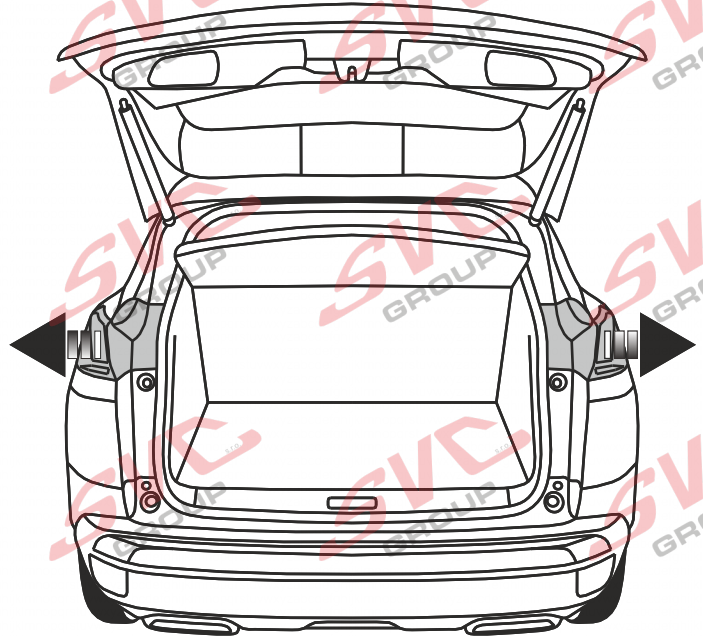

4.



x6

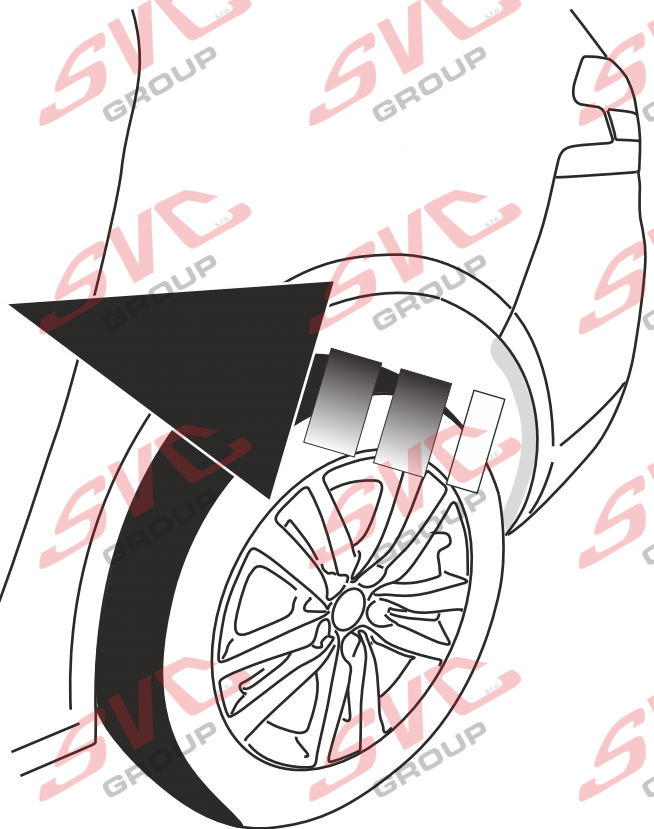
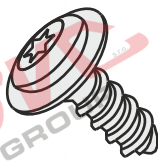

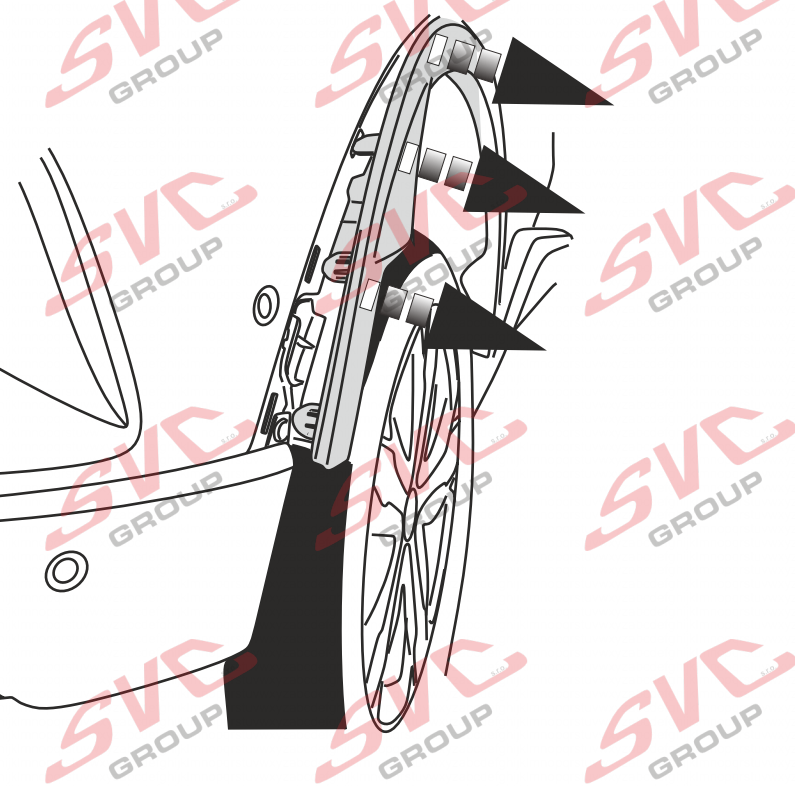
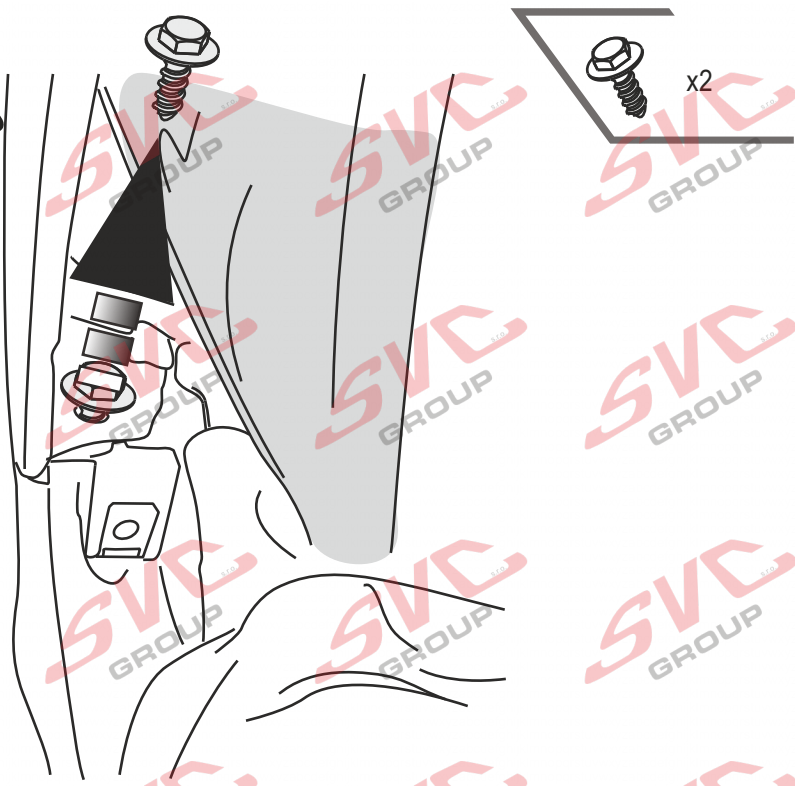
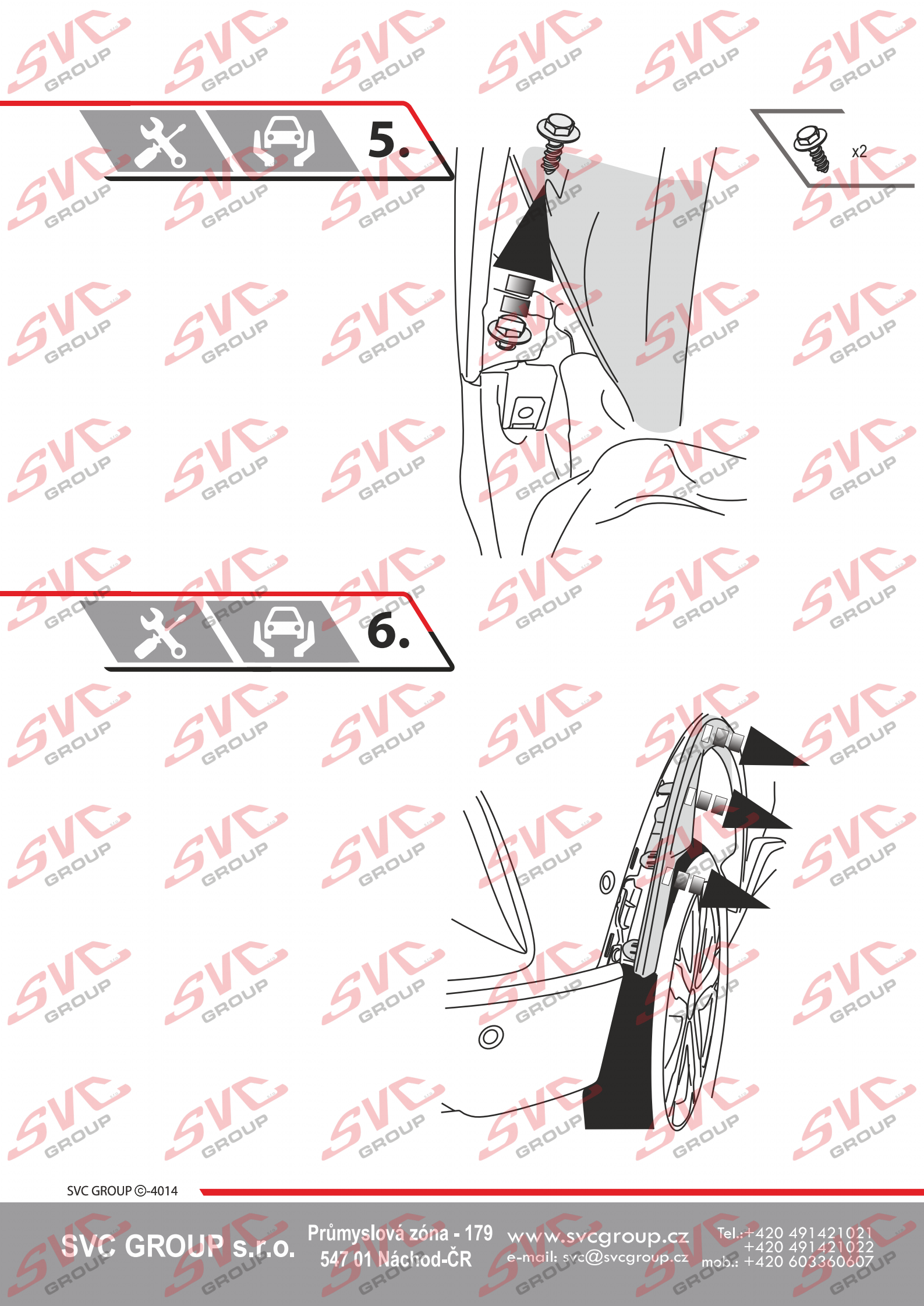

SVC GROUP ©-4014

SVC GROUP s.r.o.

Průmyslová zóna - 179
547 01 Náchod-ČR

www.svcgroup.cz
e-mail: svc@svcgroup.cz

Tel.: +420 491421021
+420 491421022
mob.: +420 603360607

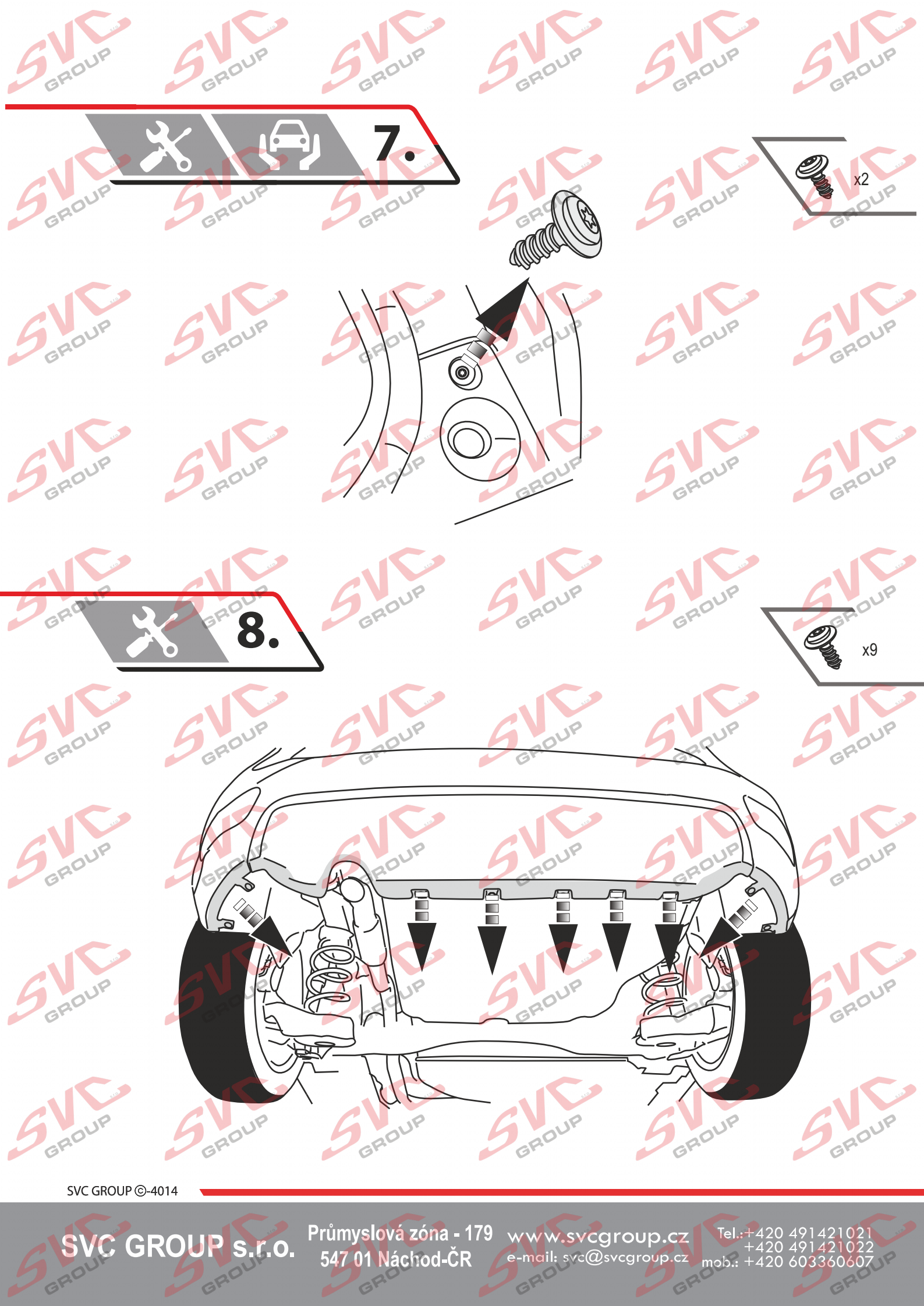

7.



x2

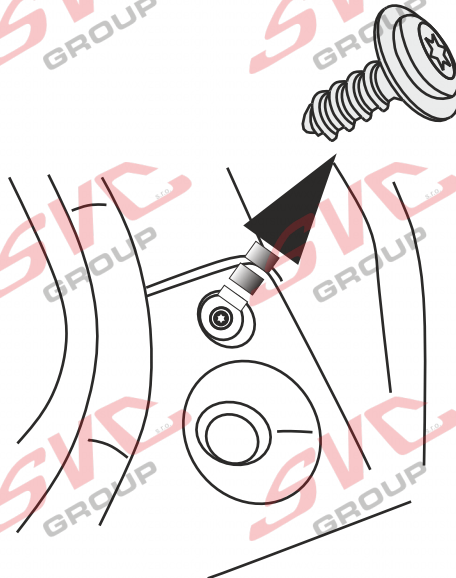

8.



x9

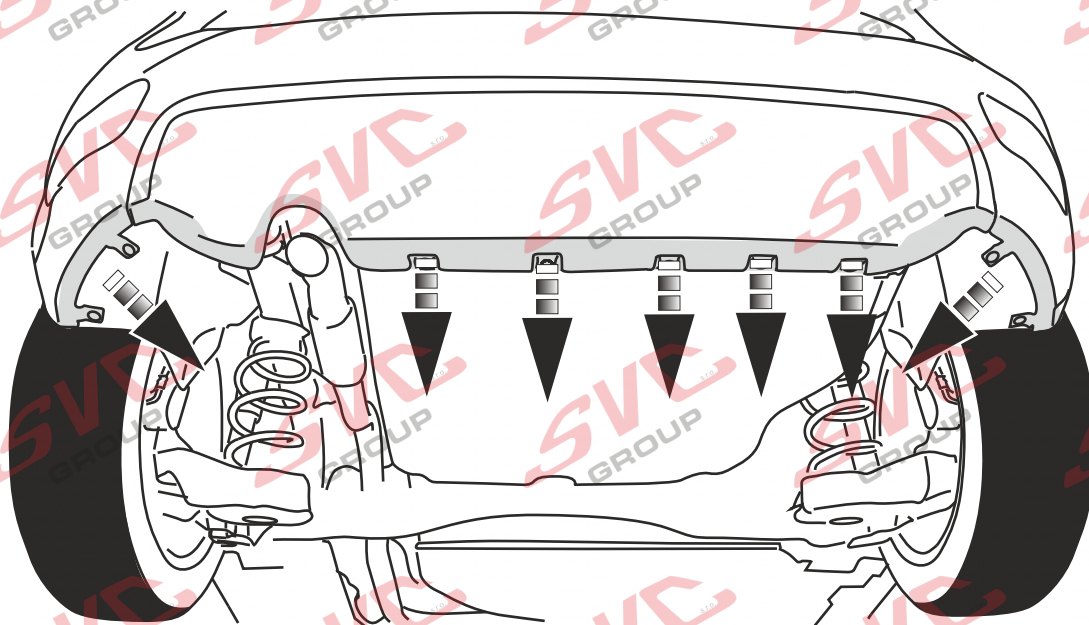

SVC GROUP ©-4014

SVC GROUP s.r.o.

Průmyslová zóna - 179
547 01 Náchod-ČR

www.svcgroup.cz
e-mail: svc@svcgroup.cz

Tel.: +420 491421021
+420 491421022
mob.: +420 603360607



9.



x2

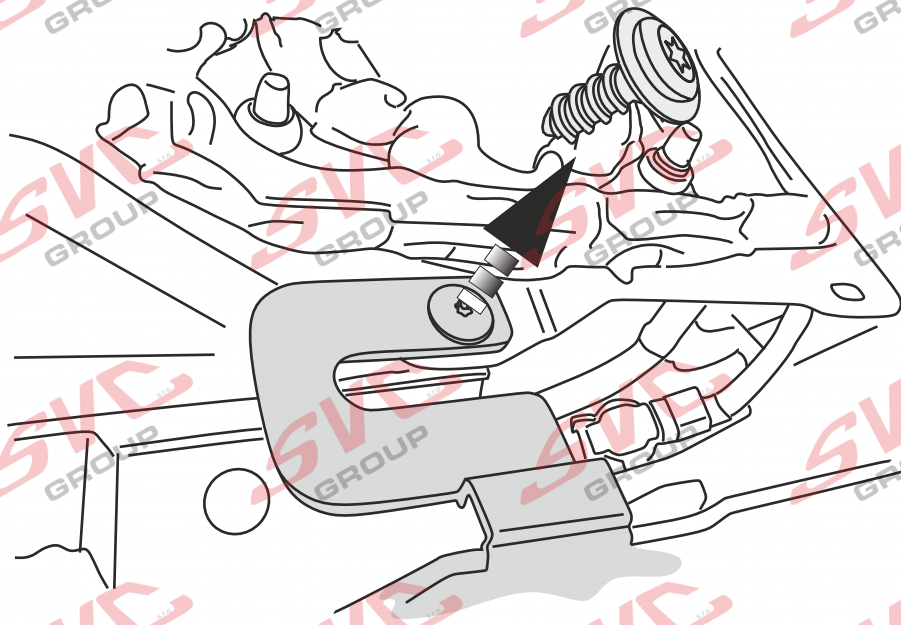

10.

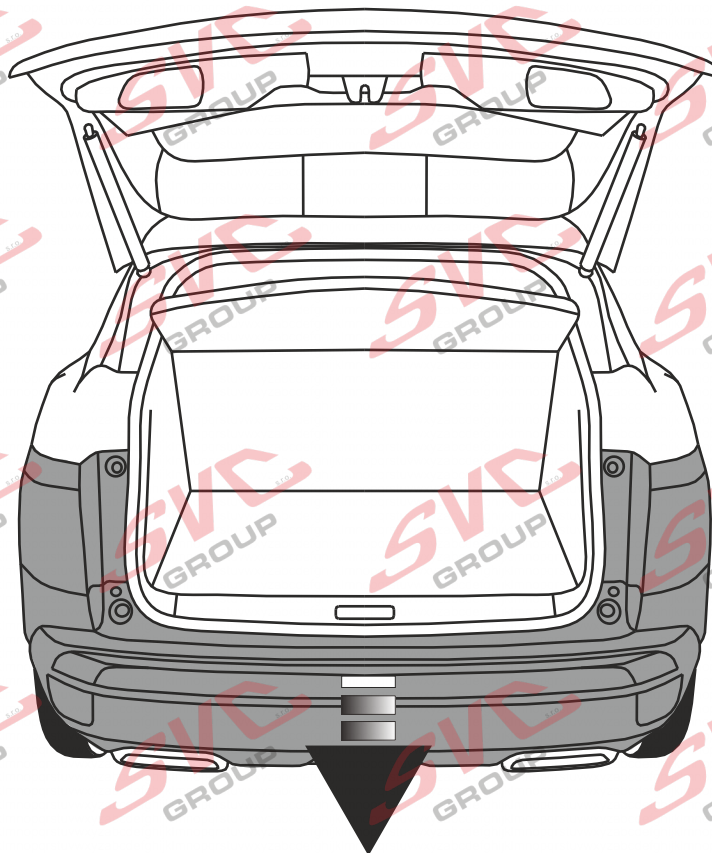

SVC GROUP ©-4014

SVC GROUP s.r.o.

Průmyslová zóna - 179
547 01 Náchod-ČR

www.svcgroup.cz
e-mail: svc@svcgroup.cz

Tel.: +420 491421021
+420 491421022
mob.: +420 603360607



11.



x4

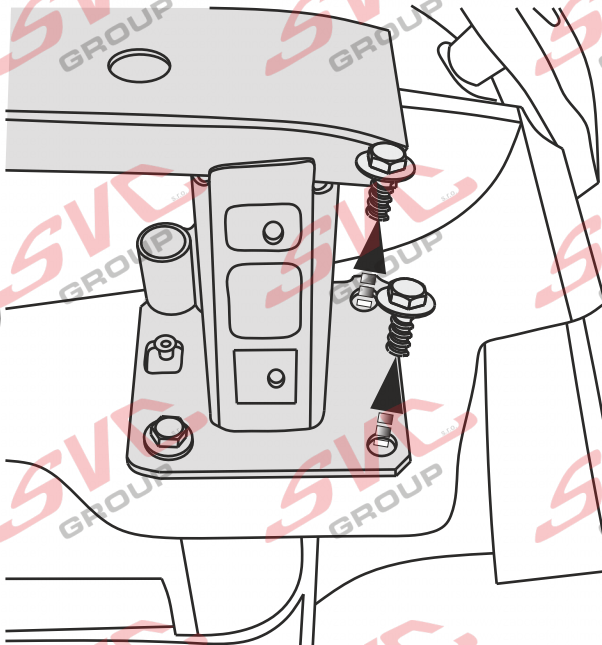
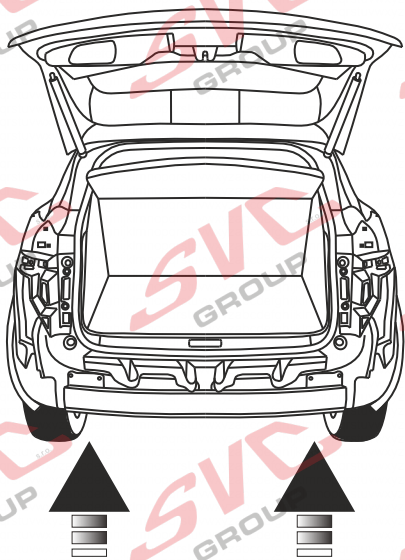

12.

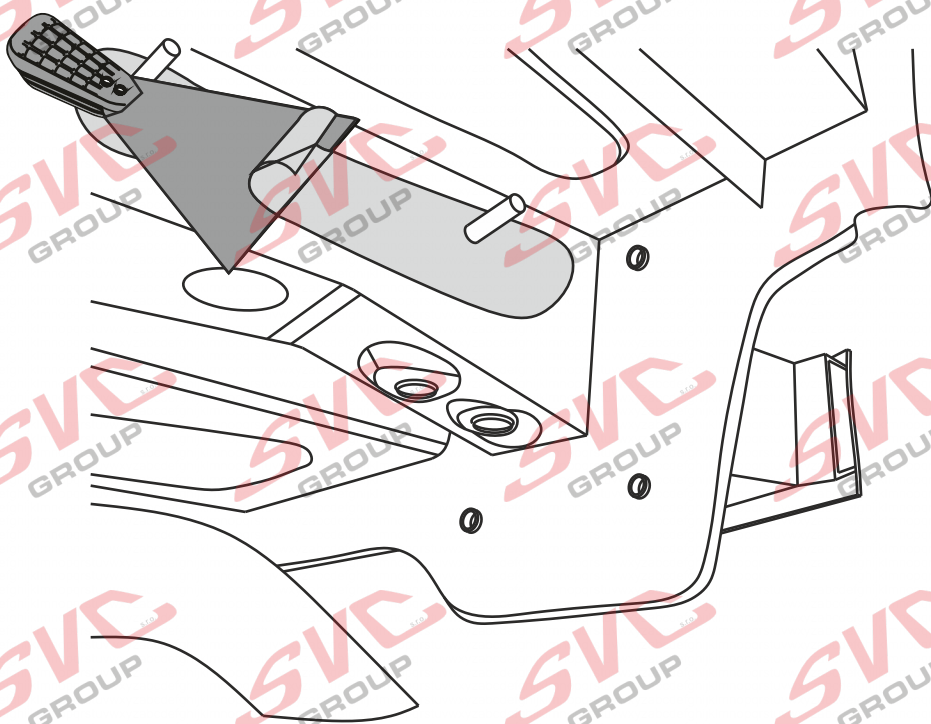
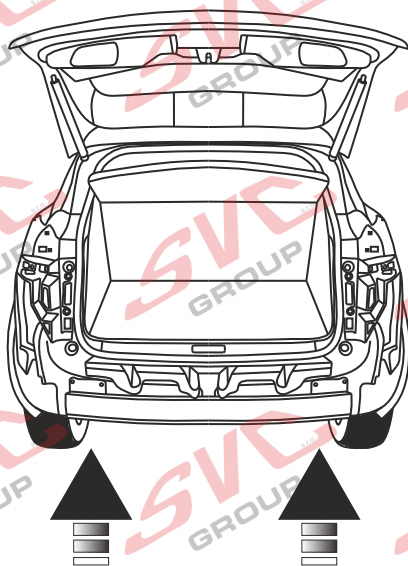

SVC GROUP ©-4014

SVC GROUP s.r.o.

Průmyslová zóna - 179
547 01 Náchod-ČR

www.svcgroup.cz
e-mail: svc@svcgroup.cz

Tel.: +420 491421021
+420 491421022
mob.: +420 603360607



13.

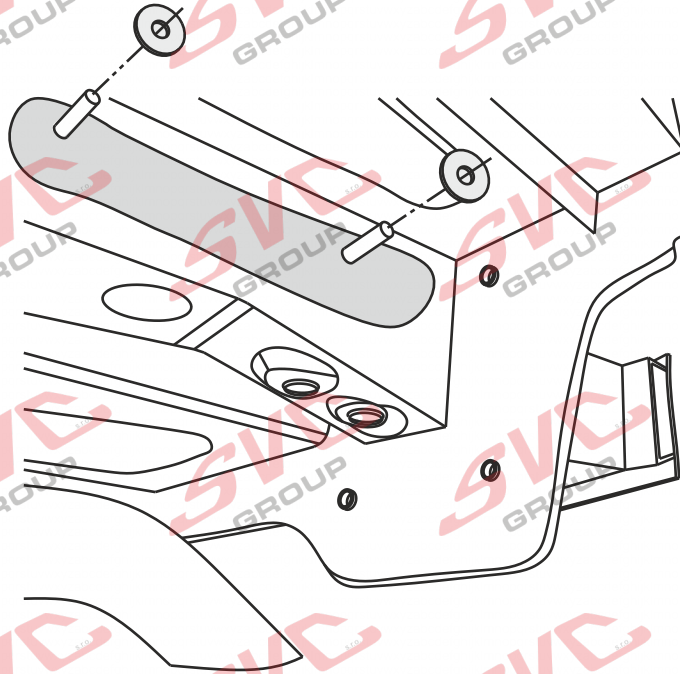
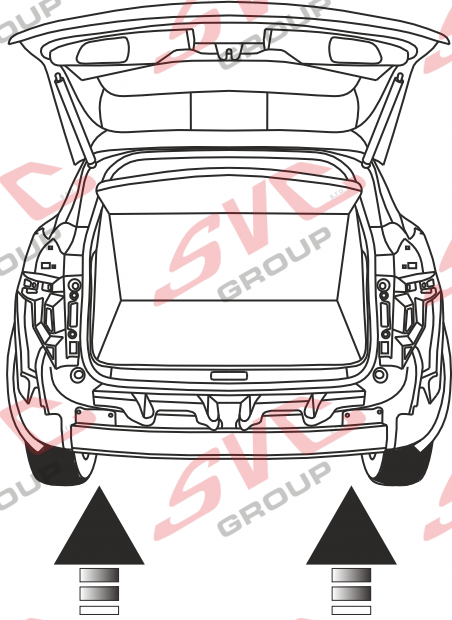

Ø10 x4



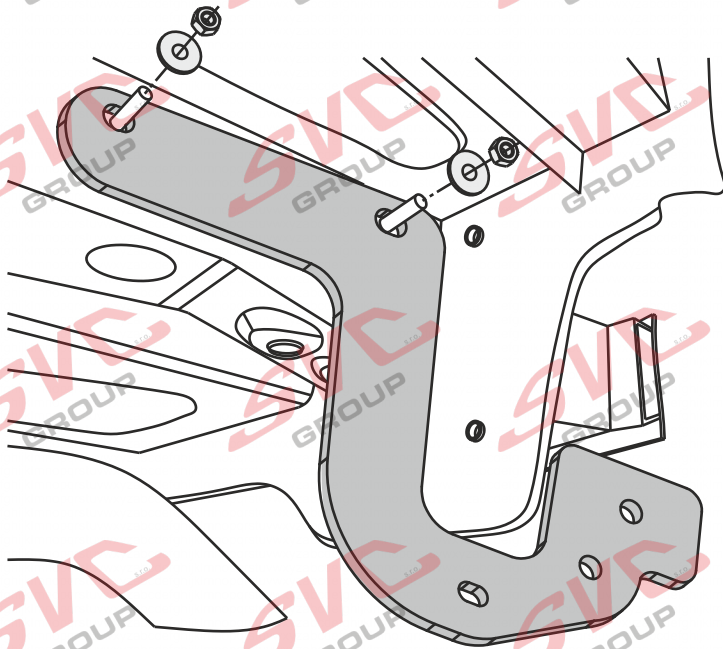
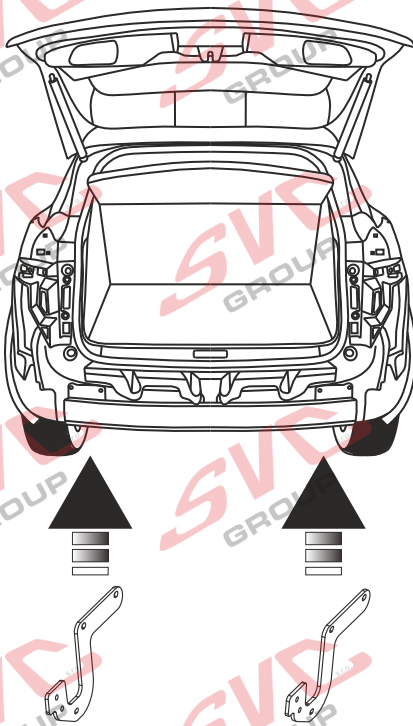

14.



M10 x4



Ø10 x4

15.

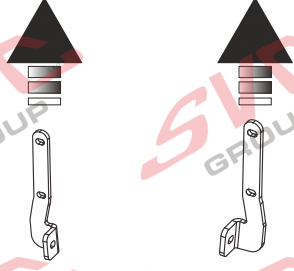
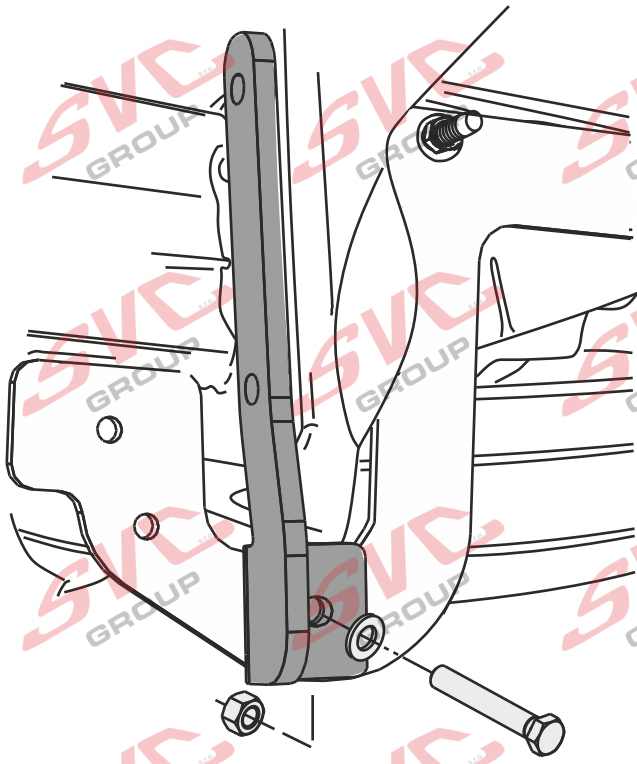
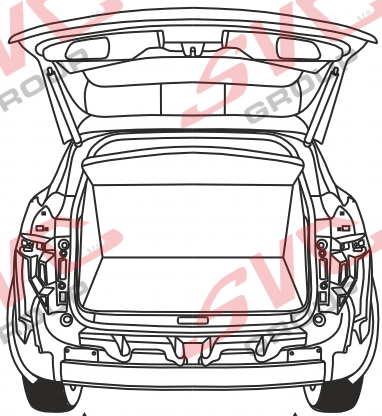
-  M10x50 x2
-  Ø10 x2
-  M10 x2



16.

-  M8x40 x4
-  Ø8 x4
-  Ø8 x4

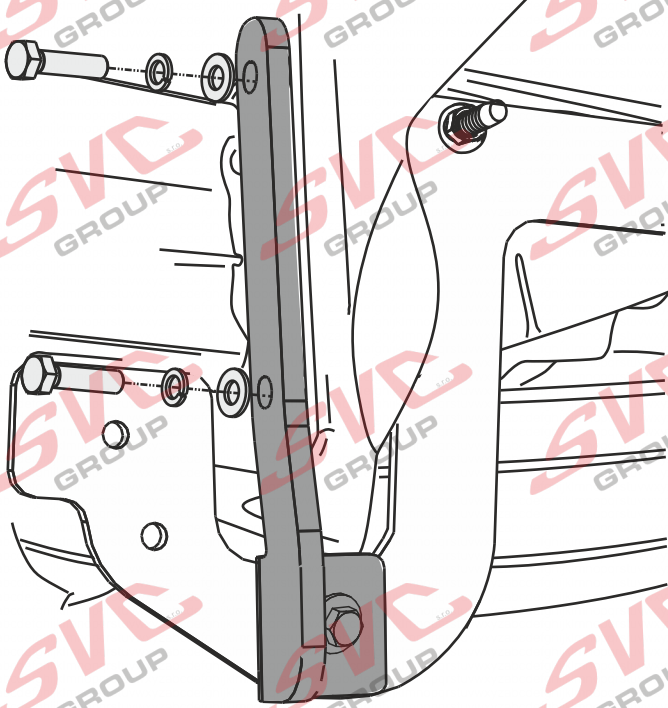
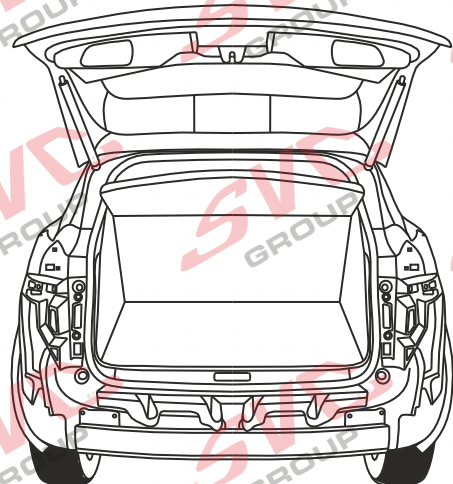



17.

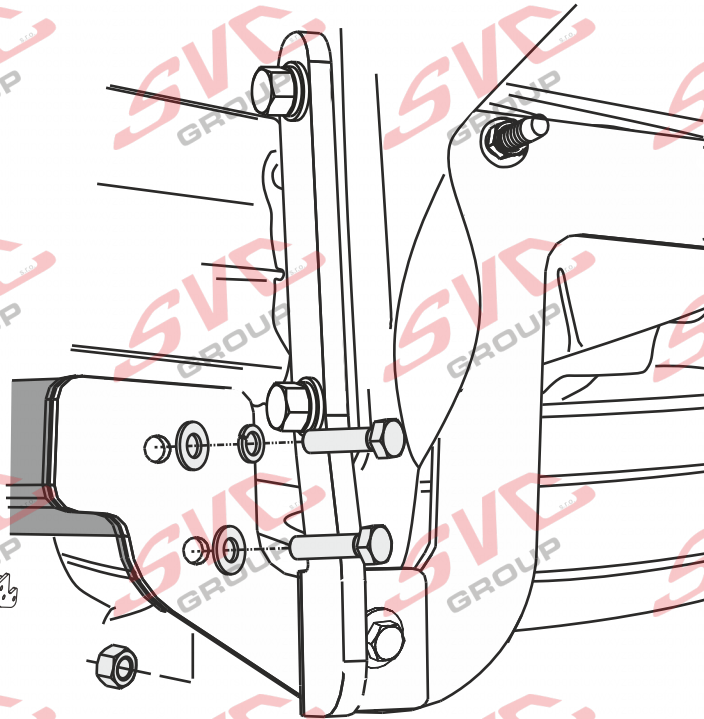
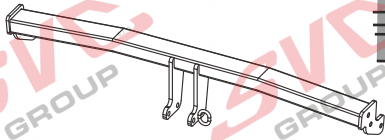
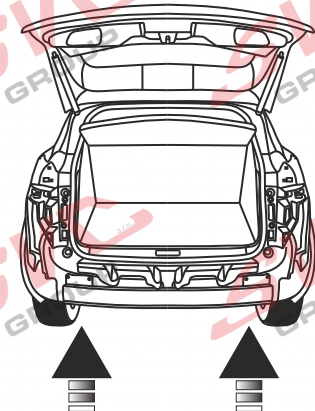
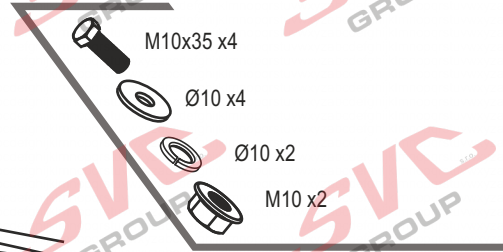

18.



VARIANTY
001/002-459-000

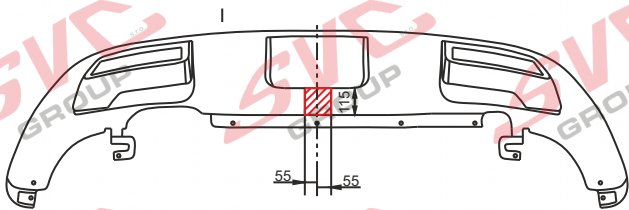

VÝŘEZ SVC

115

OSA VOZU

55

55



19.



VARIANTY
003-459-000

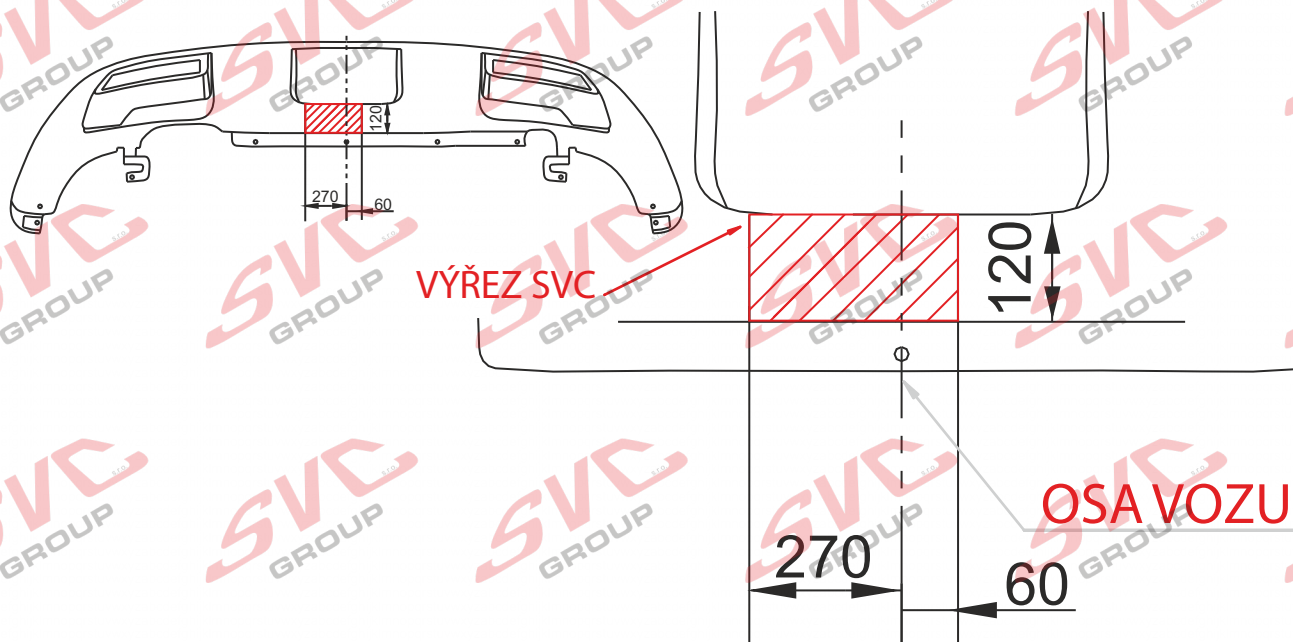

20.

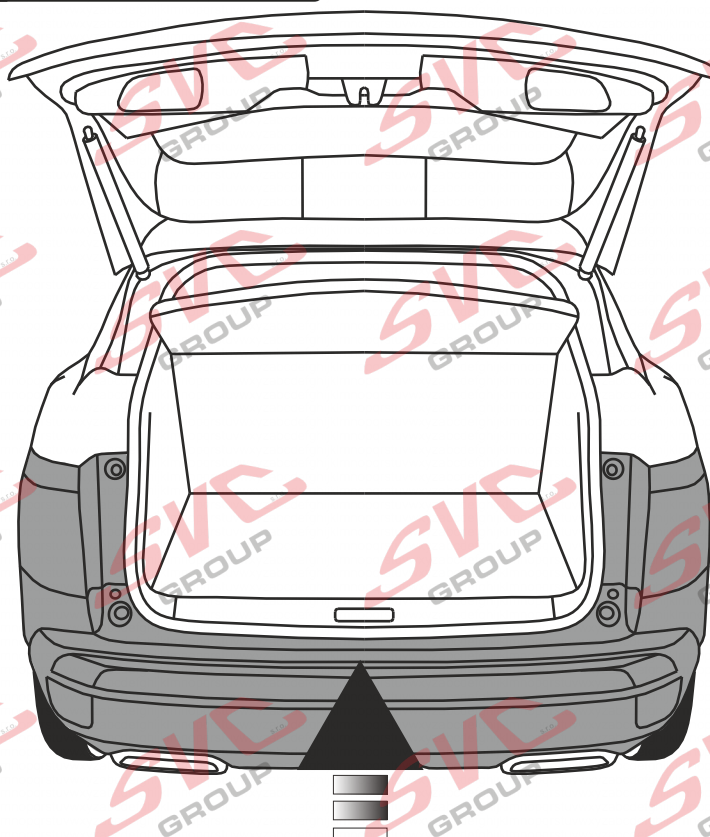

SVC GROUP ©-4014

SVC GROUP s.r.o.

Průmyslová zóna - 179
547 01 Náchod-ČR

www.svcgroup.cz
e-mail: svc@svcgroup.cz

Tel.: +420 491421021
+420 491421022
mob.: +420 603360607



21.



x2

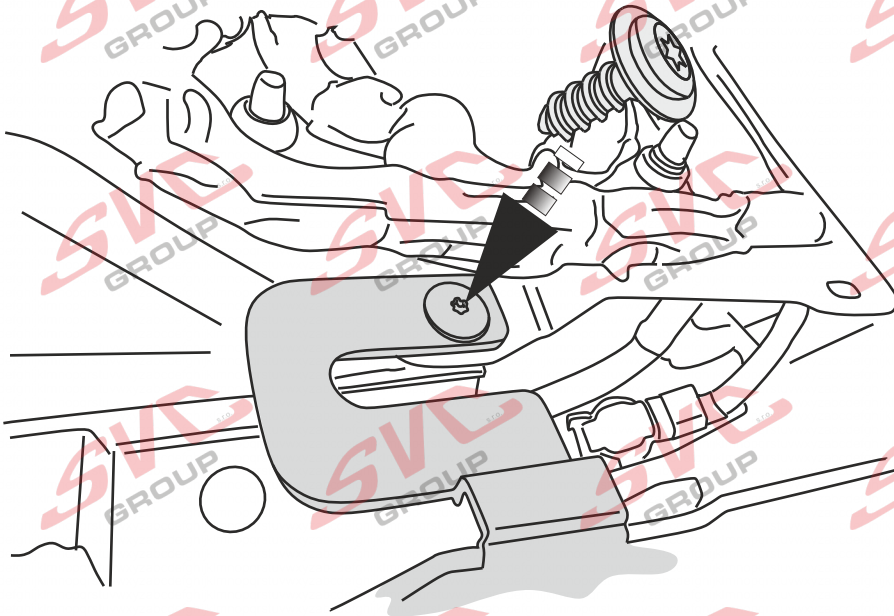

22.



x9

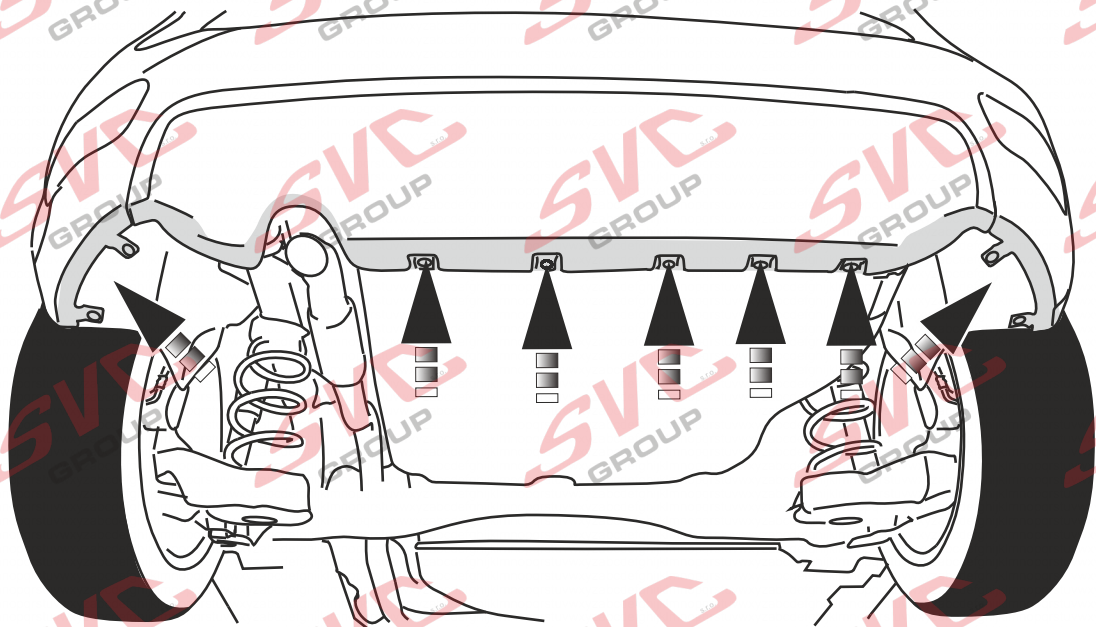



23.



x2

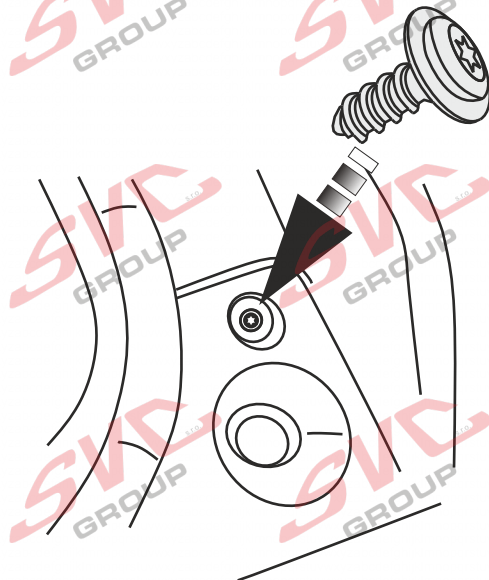

24.

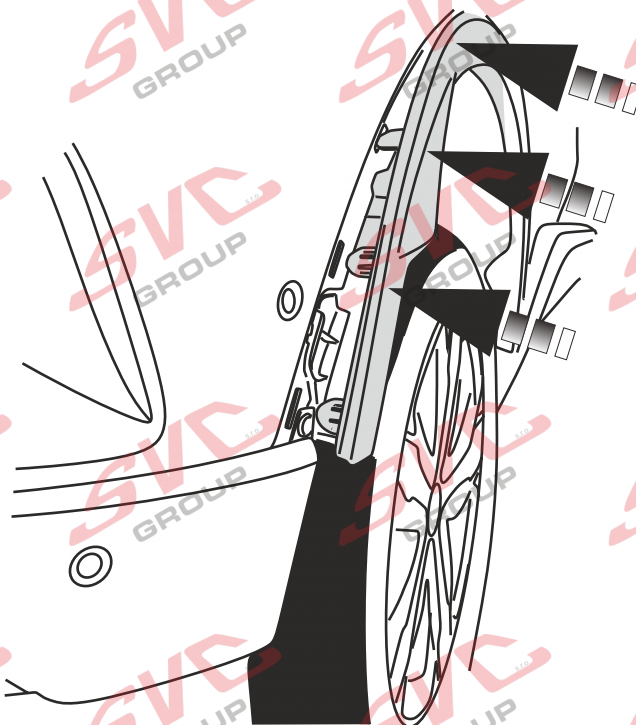



25.



x2

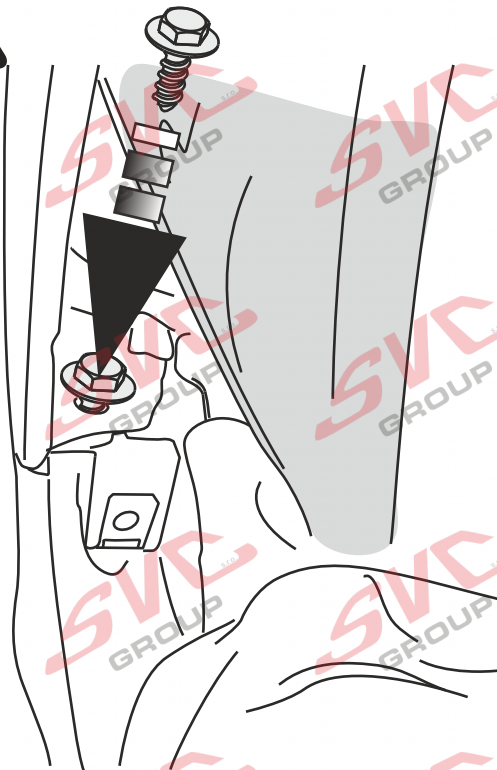

26.



x6

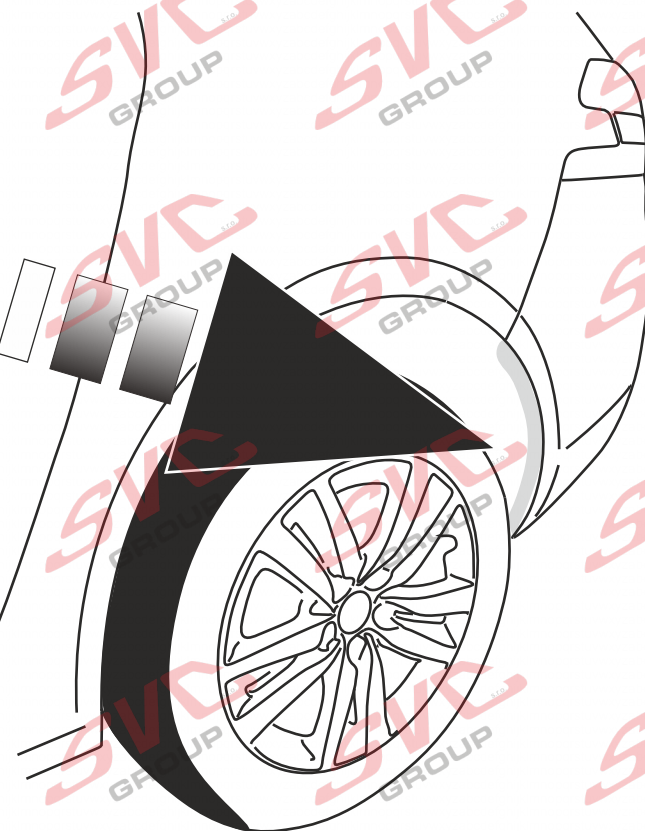
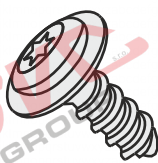

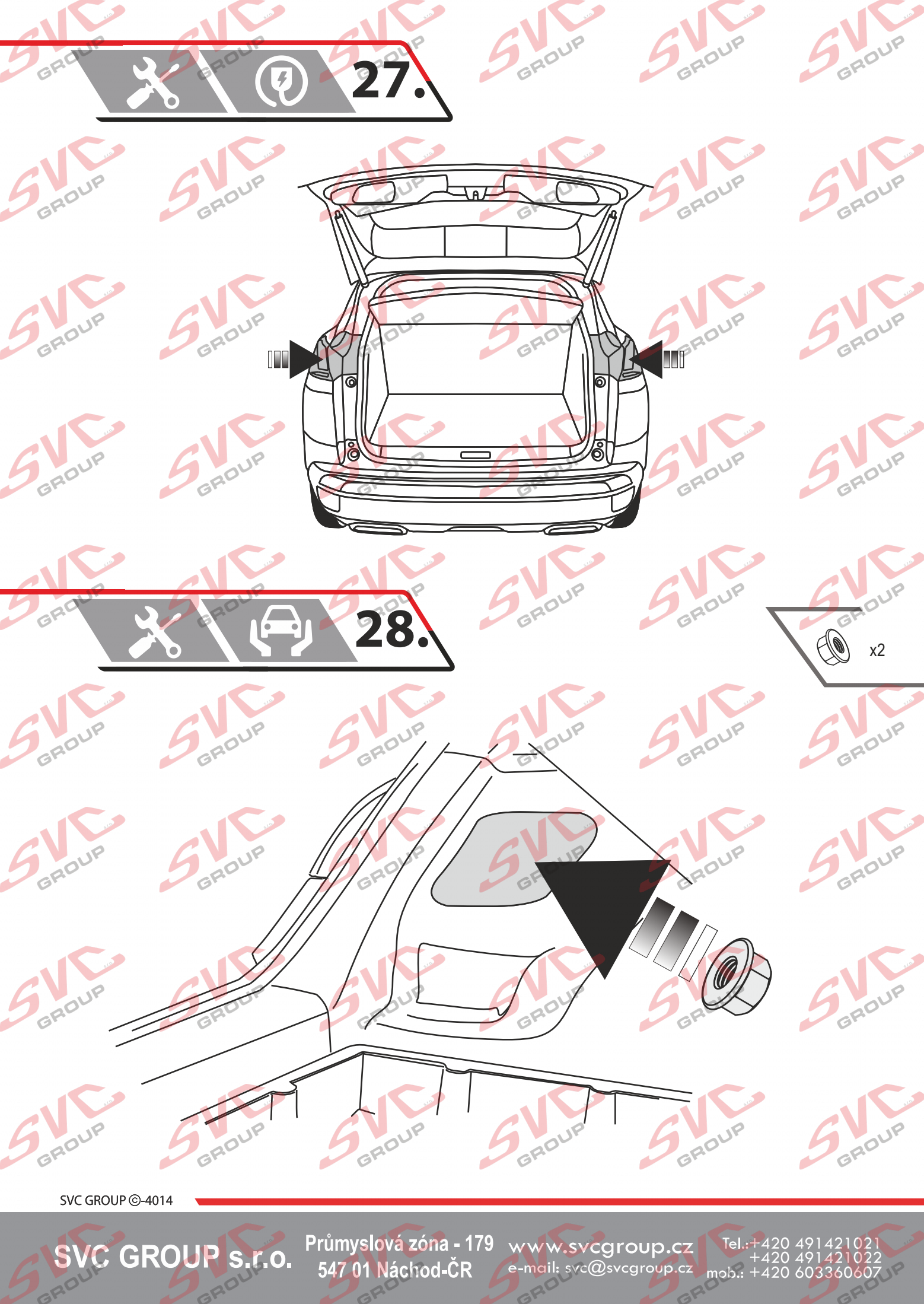

  **27.**

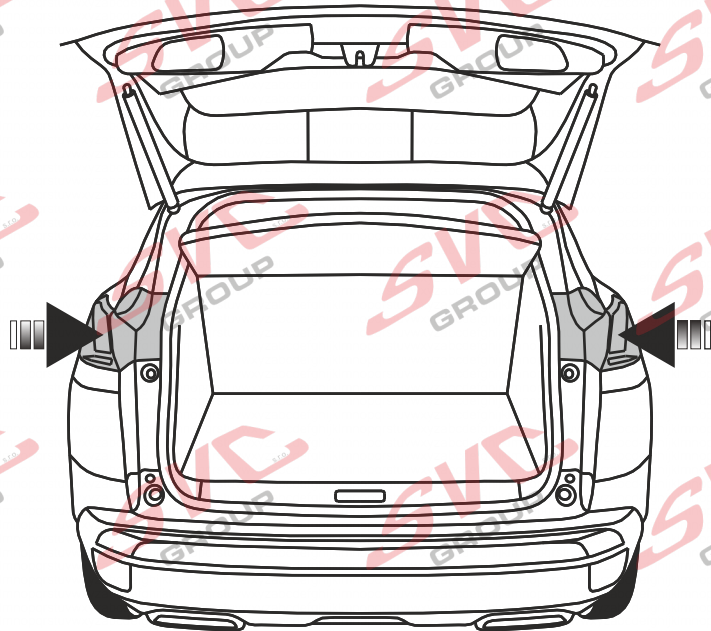

  **28.**

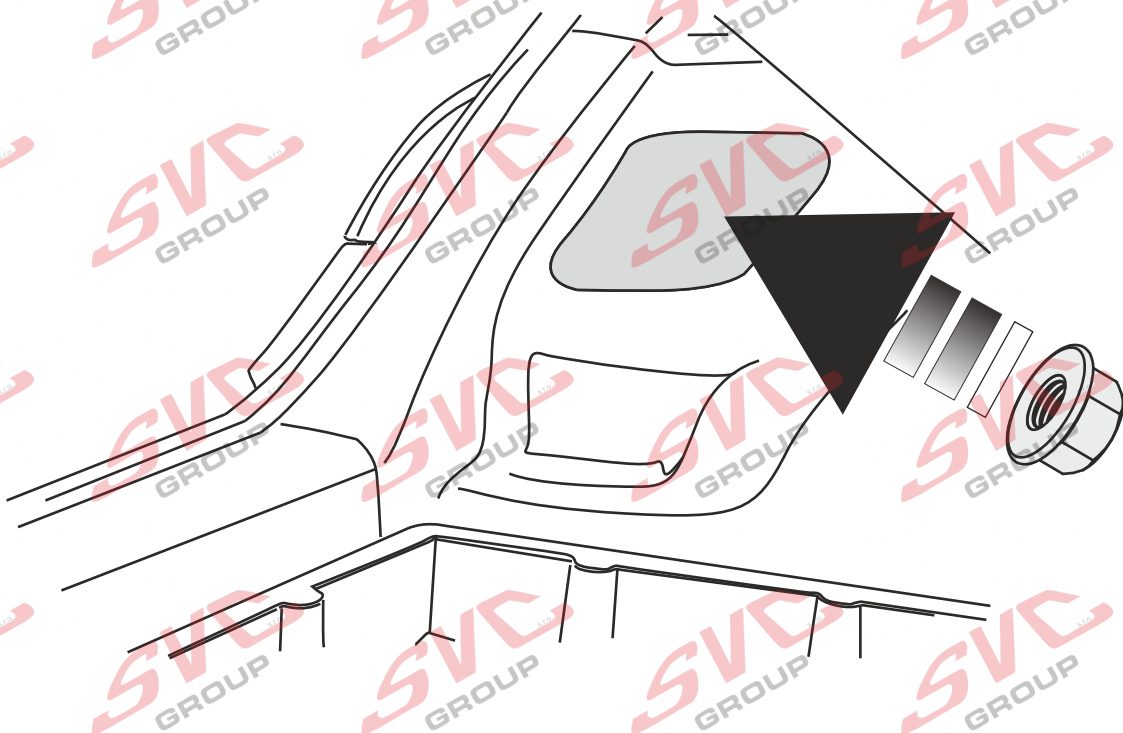



29.

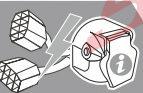
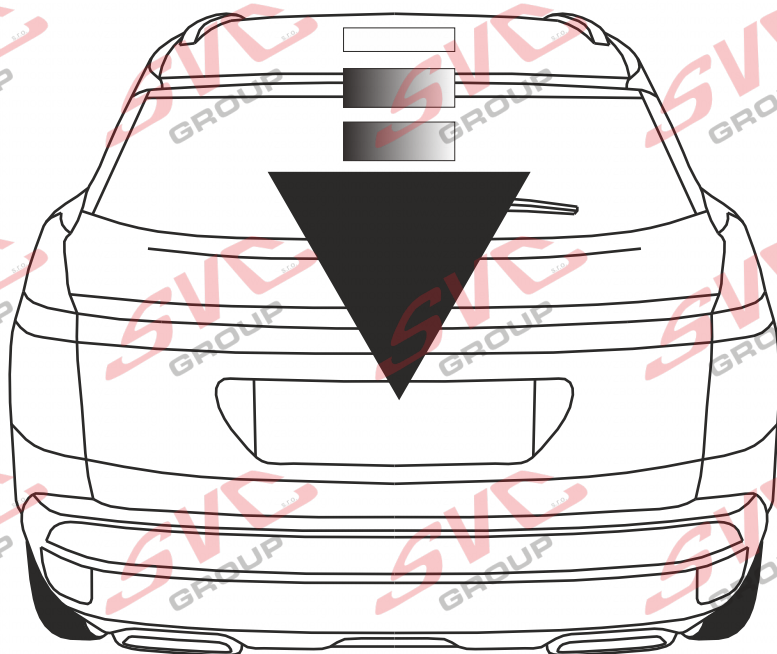

i

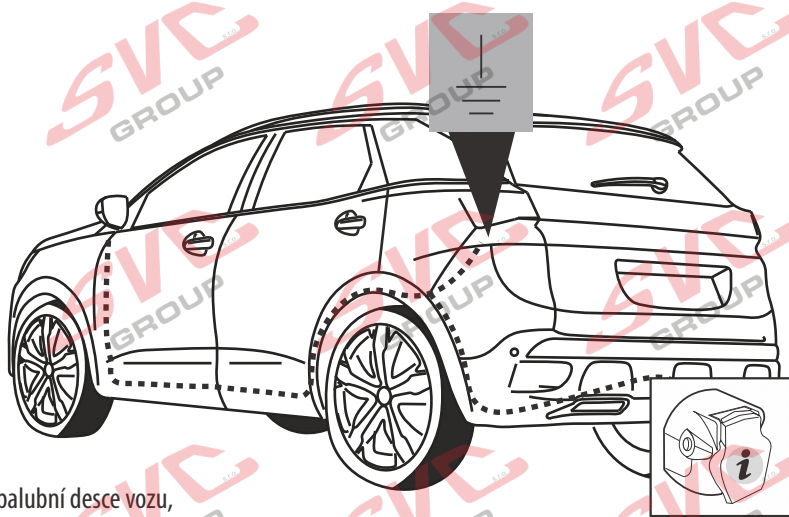

Can-Bus Autopřipojka

Vypínač pro couvací senzory PDC je umístěn na palubní desce vozu, nemusí se tedy v zavazadlovém prostoru složitě odpojovat a propojovat elektrickou instalaci vozu a autozásuvky

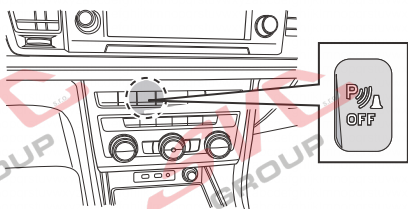

SVC GROUP ©-4014

SVC GROUP s.r.o.

Průmyslová zóna - 179
547 01 Náchod-ČR

www.svcgroup.cz
e-mail: svc@svcgroup.cz

Tel.: +420 491421021
+420 491421022
mob.: +420 603360607

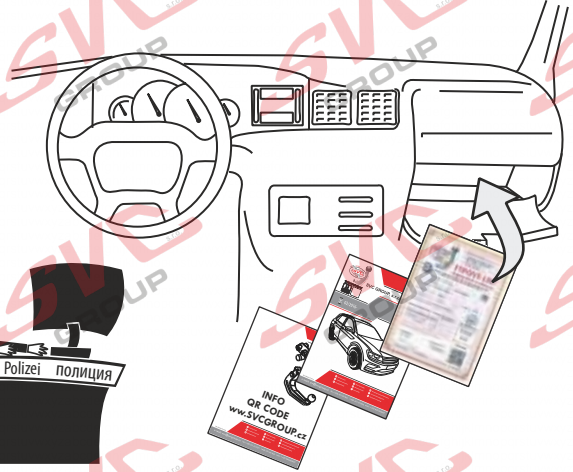
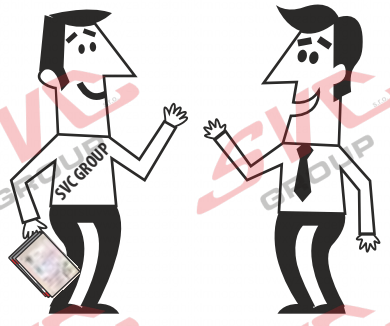

SVC GROUP, s.r.o.

Děkuje za důvěru / Dakuje za dôveru
Thank you for your trust / Danke Für dein Vertrauen
Merci pour votre conance / Grazie per la tua ducia
Tankewol foar jo fertrouwen / Спасибо за ваше доверие

Registrace / Registrácia
Registration / Registrierung
Inscription / Registrazione
Rekisteröinti / Регистрация

Nevíte si rady? Potřebujete poradit?

Náš zákaznický servis je vám k dispozici

 +420 491 421 021

 svc@svcgroup.cz



Opravdový specialista a Certifikovaný výrobce tažných zařízení s největším sortimentem v ČR. Rodinná firma s více jak 30letou ověřenou tradicí výroby, prodeje a montáže.

www.svcgroup.cz