

Montážní návod

(Montážny návod, Fitting instruction, Montageanleitung,
Istruzioni di montaggio, Monteringshandledning,
Asennusohje, Instruction de montage,
Montegehandleiding, Инструкция по установке)



Tažné zařízení

Ťažné zariadenie
Towbars
Trekhaak
Anhängerkupplung de
Dispositif d'attelage
Equipo de remolque
Sprzęt holowniczy
Hinauslaitteet
Буксирное оборудование



výrobce / dodavatel
SVC Group s.r.o.

Odkaz na produkt:

<https://www.svcgroup.cz/tazne-zarizeni-sro-uby-pevny-skoda-rapid-monte-carlo-10-20-12-2018-p7283-v960>



www.svcgroup.cz

CZ - Tažné zařízení / SK - Ťažné zariadenie / GB - Towbars / PL - Haki holownicze
DE - Anhängervorrichtungen / FR - ASELAGES / SPA - Ganchos / HUN - Vonohorgok
RUS/FIN/LIT - Фаркопы / RO - Cârlig de remorcare

TYP VTZ 1.001-514 VTZ 1.002-514 VTZ 1.003-514

www.svcgroup.cz



SVC GROUP s.r.o
Průmyslová zóna 179
547 01 Náchod
Česká republika



Hyundai i20
Hyundai BAYON



09/2020 ->>

06/2021 ->>



1->2,0 h



2->2,5 h

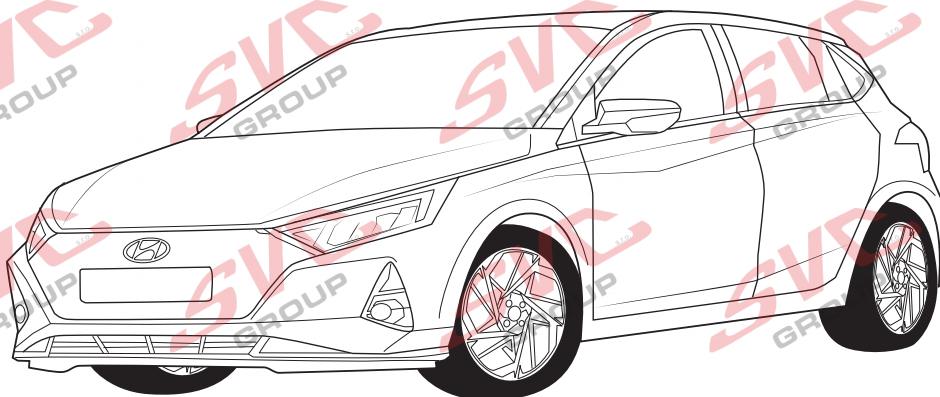
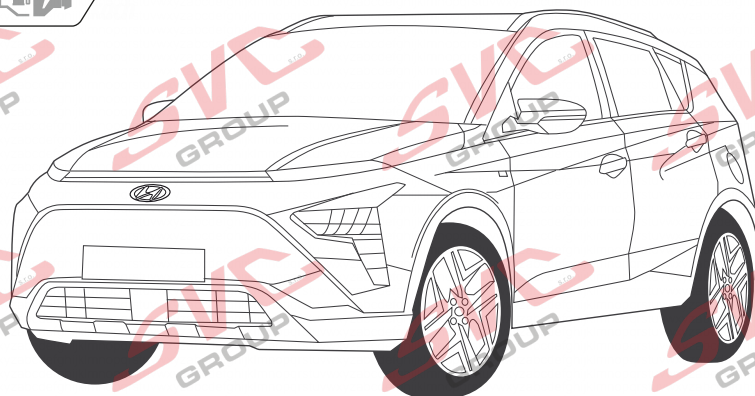

CZ Pro podrobné montážní instrukce a podmínky výroby si naskenujte QR kód
SK Pre podrobné montážne pokyny a podmienky produktu si môžete skenovať QR kód
GB For detailed installation instructions and product conditions, scan the QR code
DE Scannen Sie den QR-Code, um detaillierte Installationsanweisungen und Produktbedingungen zu erhalten
FR Pour des instructions d'installation détaillées et les conditions du produit, scannez le code QR
ITA Per istruzioni di installazione dettagliate e condizioni del prodotto, eseguire la scansione del codice QR
PL Aby uzyskać szczegółowe instrukcje dotyczące instalacji i warunki produktu, zeskanuj kod QR
SP Para obtener instrucciones detalladas de instalación y condiciones del producto, escanee el código QR
NL Voor gedetailleerde installatie-instructies en productvoorwaarden, scan de QR-code
FIN Tarkemmat asennusohjeet ja tuotteen ehdot on tarkistettava QR-koodilla
HU A részletes telepítési utasítások és a termék feltételei között olvassa el a QR kódot
SLO Za podrobna navodila za namestitve in pogoje izdelka skenirajte kodo QR
RU Подробные инструкции по установке и условиям продукта отсканируйте QR-код.

SVC GROUP ©-11/19

e-mail: scv@scvgroup.cz Tel.: +420 491421021 +420 491421022 mob.: +420 603360607



Hyundai i20
Hyundai BAYON



09/2020 ->>
06/2021 ->>



VTZ 1.001-514



VTZ 1.002-514



VTZ 1.003-514

HYUNDAI BAYON

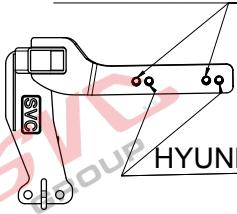

HYUNDAI BAYON

HYUNDAI i20 M5x16
HYUNDAI BAYON M8x25

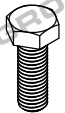

M12x35 4x
M8x25 2x HYUNDAI BAYON
M5x16 2x HYUNDAI i20



Ø12 4x



Ø12 4x
Ø8 4x HYUNDAI BAYON
Ø5 4x HYUNDAI i20



M8 2x HYUNDAI BAYON
M5 2x HYUNDAI i20

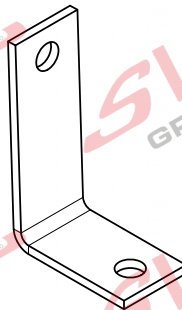

2x HYUNDAI BAYON

85 1 500 D= 7,64



kN



BRZDĚNÍ - BRAKE - GEBREMS
Classe A50-X
Přívěs
Trailer

M12x35 2x

POUZE / ONLY
HYUNDAI BAYON

POUZE / ONLY
HYUNDAI BAYON

M12x35 2x

HYUNDAI i20 M5x16
HYUNDAI BAYON M8x25

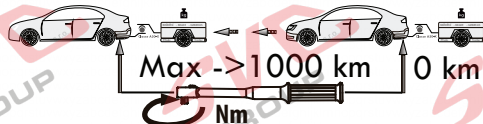
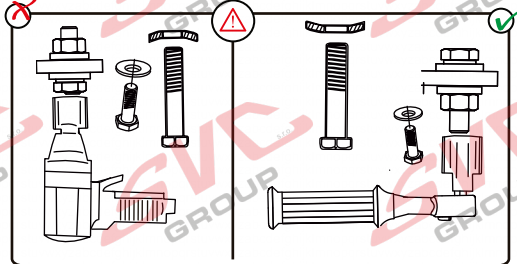

Pevnost	8,8	10,9	12,9
M6	9,7	14,3	16,1
M8	24,5	35,9	42,0
M10	48,4	71,0	83,0
M12	84,0	123,0	144,0
M14	133,0	196,0	229,0
M16	137,0	307,0	359,0

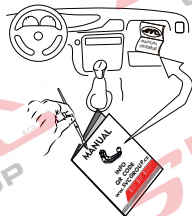

Nm



Homologace EHK 55-R

55R-01-0581

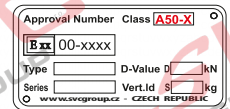

- | | |
|---|--|
| CZ Informace k provozu / homologaci | NL Monteringsanvisningar |
| SK Informácie na prevádzku / homologáciu | ES Instrucciones de montaje |
| EN Operating / homologation information | FIN Montage-instructie |
| DE Betriebs- / Zulassungsinformationen | SV Asennusohjeet |
| HU Üzemeltetési / homologációs információk | NOR Drifts- / homologasjonsinformasjon |
| FR Informations d'exploitation / homologatio | PL Informacje dotyczące pracy / homologacji |
| IT Informazioni sull'operazione / omologazio | RU Информация о работе / омологации |



Hyundai i20
Hyundai BAYON



09/2020 ->>
06/2021 ->>

N-1

CS Montážní návod

Pro podrobné montážní instrukce a podmínky výrobku si naskenujte QR kód

- Odmontujte zadní světla, nárazník i s jeho plastovou výztuhou a uvolněte plastová nadkolí.
- Do nosníků odzadu vsuňte tažné zařízení a přichyťte 4 šrouby M12x35 s velkoplošnými podložkami. Tažné zařízení vyrovnejte a dotáhněte dle utahovacích momentů
- Vymontujte plastovou výztuhu z nárazníku (tato nebude již zapotřebí)
Z této odmontujte spodní plastové držáky nárazníku a namontujte na tažné zařízení za pomoci 2 šroubů M5x16. Elektrickou instalaci z výztuhu přichyťte k nárazníku plastovými páskami.
- Zhotovte výřez do spodního krycího plastu a nárazníku dle obrázku. Namontujte zpět všechny díly odmontované v bodě č.1.

EN Installation instructions

For detailed installation instructions and product conditions, scan the QR code

- Remove rear lights and bumper with its plastic stienner and release plastic wheel arches.
- From behind, insert the tow bar into the beam and x it using 4 screws M12x35 and large-area washers. Align all the parts of the tow bar and tighten them to prescribed torques
- Remove the plastic stienner from the bumper (it is no longer needed). Remove the lower plastic bumper brackets from the stienner and mount them on the tow bar using two screws M5x16. Use plastic straps to attach the wiring from the stienner to the bumper.
- Make a cut-out in the lower cover plastic part and the bumper as shown in the picture. Reinstall all the parts removed within the step 1.

SK Montážny návod

Pre podrobné montážne pokyny a podmienky produktu si môžete skenovať QR kód

- Od s jeho zadným svetlom, nárazníkom i plastovou výztuhou a uvoľníte plastovú nadkolí.
- Do nosníkov od zadu vsuňte ťažné zariadenia a prichyťte 4 skrutky M12x35 s veľkoplošnými podložkami. Ťažné zariadenie vyrovnejte a pretiahnite podľa utahovacích momentov
- Vy aktivujte nárazník z nárazníka (tato již nebude potřeba) Z této od stávajícího spodního plastového držáku a na stávající kryt za pomoci 2 M5x16. Elektrickou instalaci z výztuhu přichyťte k nárazníku plastovými páskami.
- Zhotovený výřez do spodního krycího plastu a nárazníku dle obrázku. Na ukazuje späť všetky diely odmontované v bode č.1.

DE Montageanleitung

Scannen Sie den QR-Code, um detaillierte Installationsanweisungen und Produktbedingungen zu erhalten

- Die Hecklichter, Stoßstange samt Kunststoffstrebe ausbauen und Kunststoffverkleidung über Radkasten lösen.
- In die Träger die Zugeinrichtung von hinten einfügen und mit 4 Schrauben M12x35 mit großen Unterlegscheiben befestigen. Die Zugeinrichtung ausrichten und mit den entsprechenden Momenten festziehen.
- Die Kunststoffstrebe aus der Stoßstange ausbauen (sie wird nicht mehr nötig sein). Aus dieser untere Kunststoffhalter der Stoßstangen entfernen und sie auf die Zugeinrichtung mit 2 Schrauben M5x16 montieren. Elektroinstallation aus der Strebe zur Stoßstange mit Kunststoffbändern befestigen.
- In die untere Kunststoffabdeckung und in die Stoßstange einen Ausschnitt gemäß Abbildung herstellen. Alle im Punkt Nr. 1 ausgebauten Teile wieder einbauen.

PL Instrukcja montażu

Aby uzyskać szczegółowe instrukcje instalacji i warunki produktu, zeskanuj kod QR

- Demontujemy tylne lampy, zderzak i jego plastikowe wzmocnienie oraz uwalniamy plastikowe nadkole.
- Do belek wsuwamy od tyłu hak holowniczy i przymocowujemy go 4 śrubami M12x35 z podkładkami wielkopowierzchniowymi. Ustawiamy równo hak holowniczy i przykręcamy go z zachowaniem wymaganych momentów dokręcania.
- Ze zderzaka demontujemy plastikowe wzmocnienie (nie będzie już potrzebne). Demontujemy z niego dolne plastikowe uchwyty do zderzaka i przykręcamy je do haka holowniczego za pomocą 2 śrub M5x16. Instalację elektryczną ze wzmocnienia przymocowujemy do zderzaka opaskami plastikowymi.
- W dolnej plastikowej osłonie i w zderzaku wykonujemy wycięcie zgodnie z rysunkiem. Montujemy z powrotem wszystkie części zdemontowane w punkcie nr 1.

FR Notice de montage

Pour des instructions d'installation détaillées et les conditions du produit, scannez le code QR

- Déposer les phares arrière, le pare-chocs ainsi que son renfort en plastique et desserrer les passages de roue en plastique.
- À partir de l'arrière, insérer le dispositif d'attelage dans les longerons et xer à l'aide de 4 vis M12x35 munies de grandes rondelles. Égaliser le dispositif d'attelage et resserrer aux couples préconisés
- Retirer le renfort en plastique du pare-chocs (celui-ci ne sera nécessaire) Déposer les supports inférieurs en plastique des pare-chocs du renfort et monter les sur le dispositif d'attelage à l'aide de 2 vis M5x16. Fixer l'installation électrique du renfort au pare-chocs à l'aide des bandes en plastique.
- Selon le dessin, faire une découpe dans la pièce inférieure couvrante en plastique et le pare-chocs. Reposer toutes les pièces déposées au point n°1.

FI Asennusohje

Tarkemmat asennusohjeet ja tuotteen ehdot on tarkistettava QR-koodilla

- Déposer les phares arrière, le pare-chocs ainsi que son renfort en plastique et desserrer les passages de roue en plastique.
- À partir de l'arrière, insérer le dispositif d'attelage dans les longerons et xer à l'aide de 4 vis M12x35 munies de grandes rondelles. Égaliser le dispositif d'attelage et resserrer aux couples préconisés
- Retirer le renfort en plastique du pare-chocs (celui-ci ne sera nécessaire) Déposer les supports inférieurs en plastique des pare-chocs du renfort et monter les sur le dispositif d'attelage à l'aide de 2 vis M5x16. Fixer l'installation électrique du renfort au pare-chocs à l'aide des bandes en plastique.
- Selon le dessin, faire une découpe dans la pièce inférieure couvrante en plastique et le pare-chocs. Reposer toutes les pièces déposées au point n°1.

SVC GROUP s.r.o.

Průmyslová zóna - 179
547 01 Náchod-ČR

www.svcgroup.cz
e-mail: svc@svcgroup.cz

Tel.: +420 491 421 021
+420 491 421 022
mob.: +420 603 360 607

QR k

tructions

SVC GROUP ©- 05/19

1.

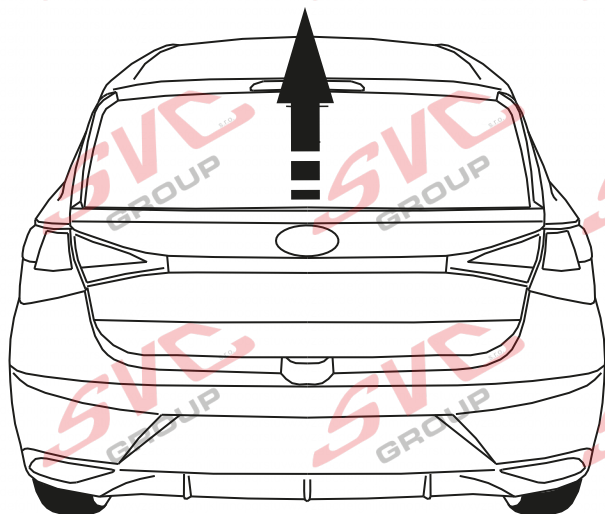

Montážní návod
Montážny návod
Installation instructions
Installationsanleitung
Instructions d'installation
Інструкція по установке

2.

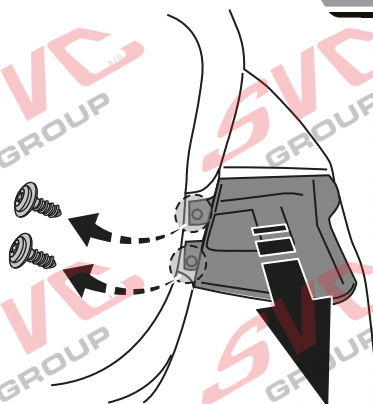
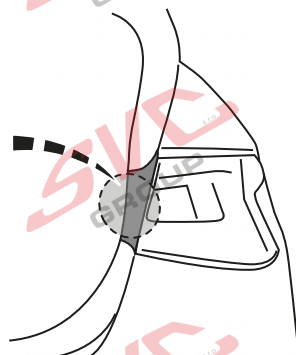
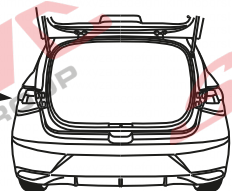

3.

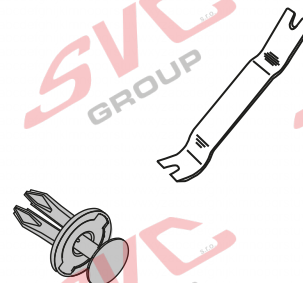
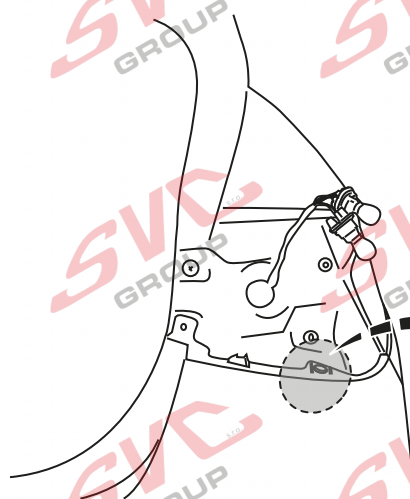

4.

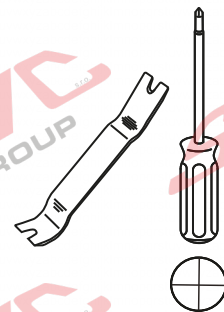
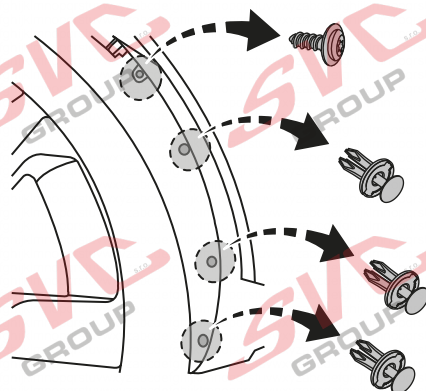
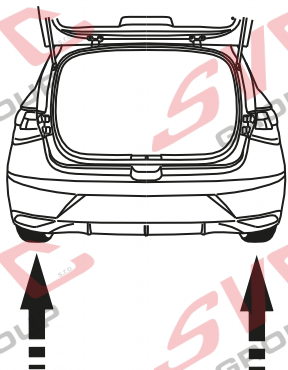

5.

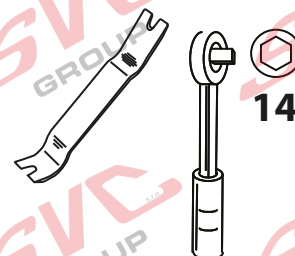
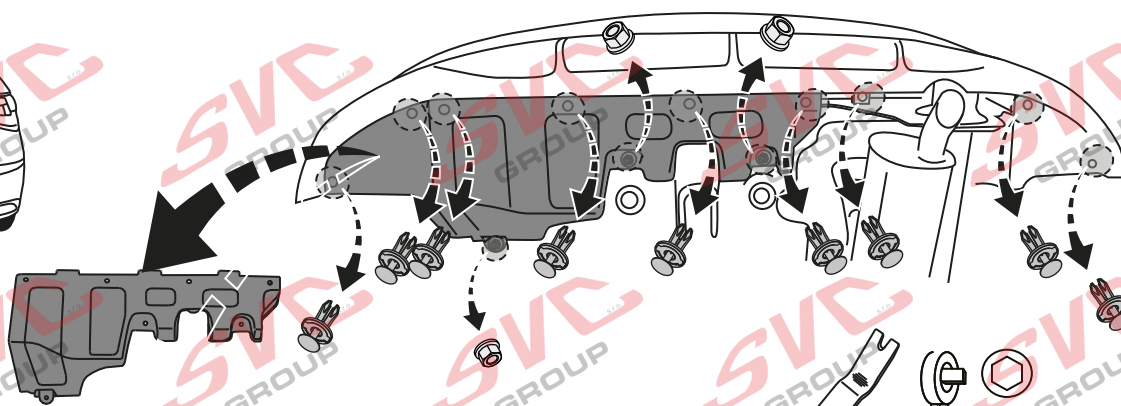
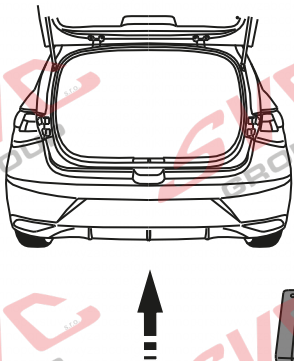

6.

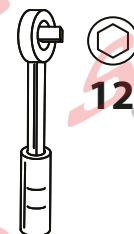
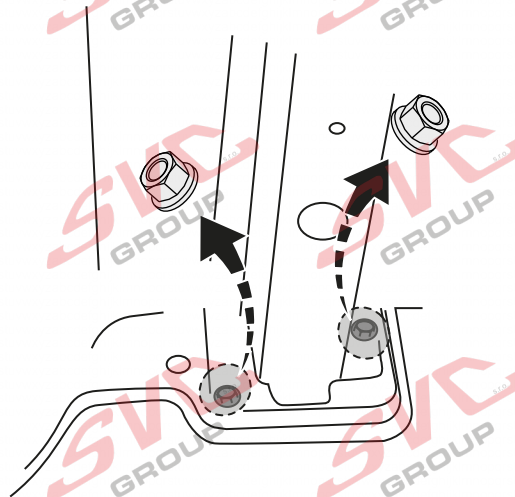

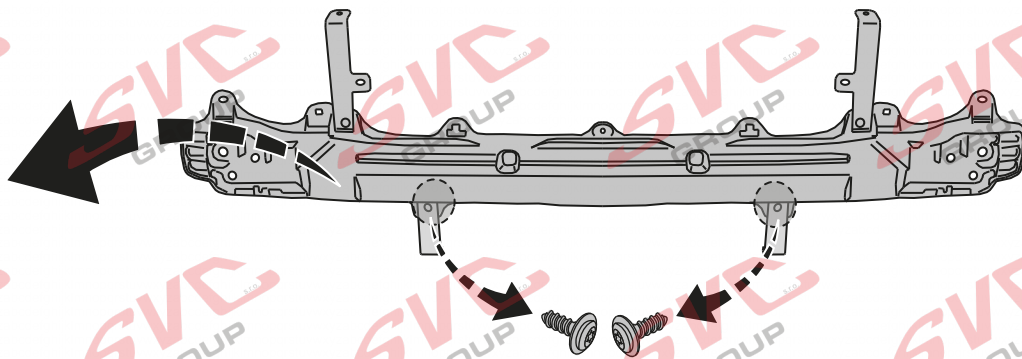
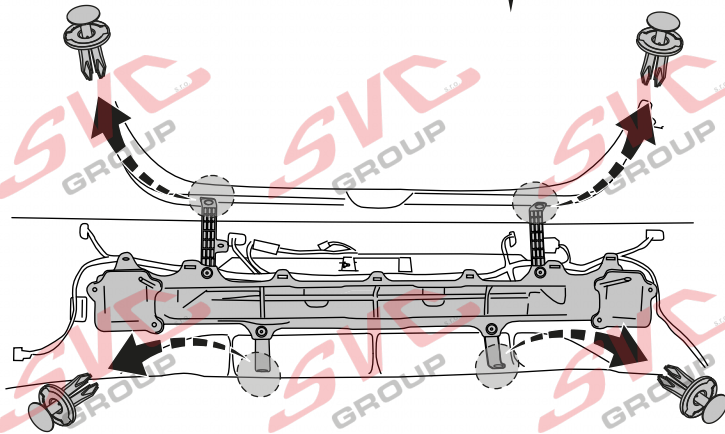
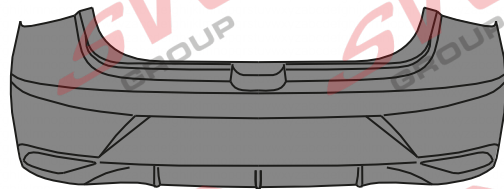
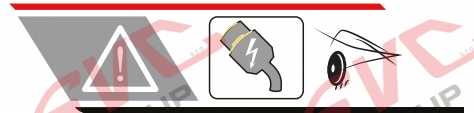
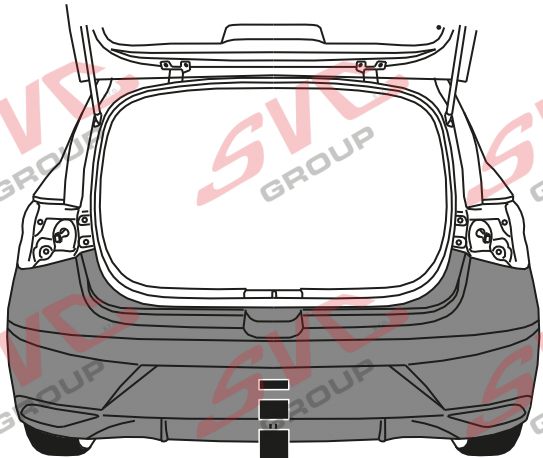

9.

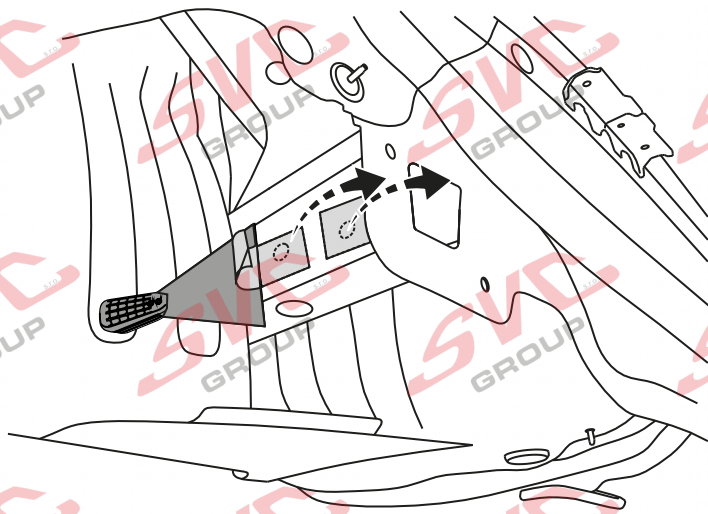
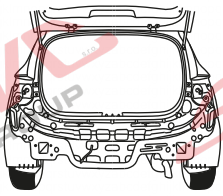

10.

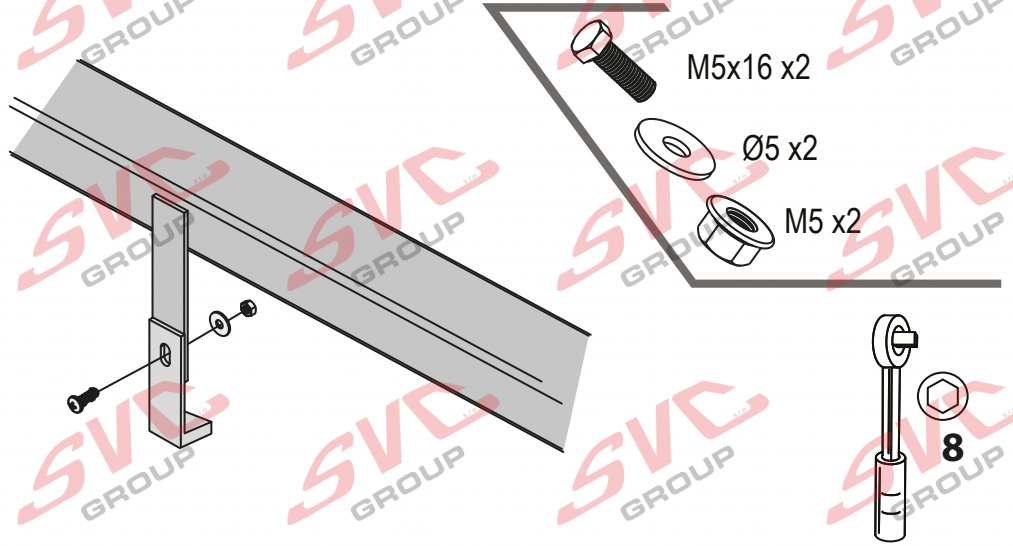
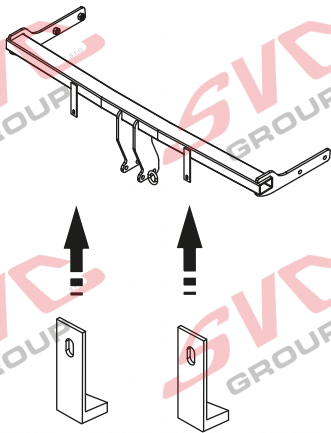

11.

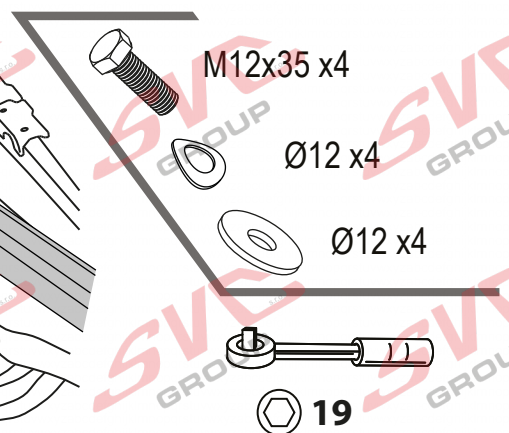
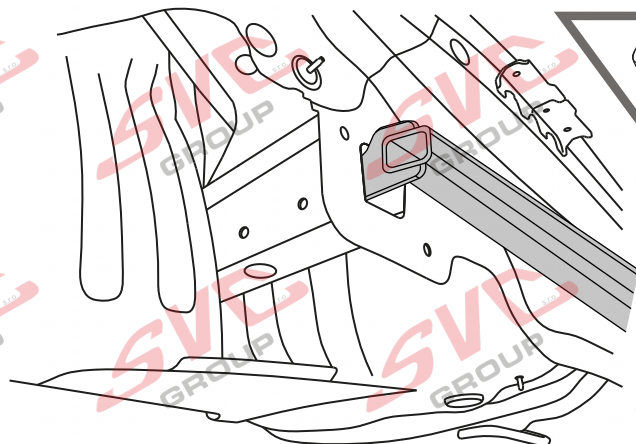
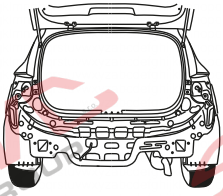
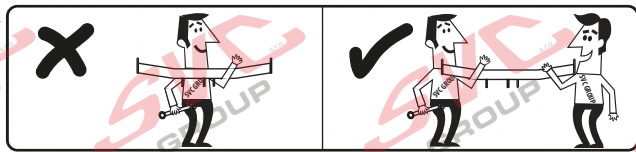



12.

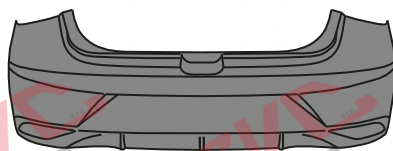

220

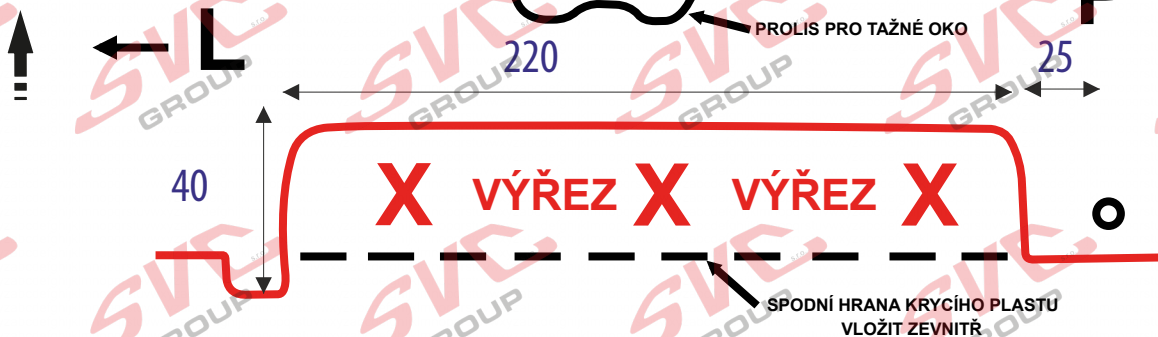
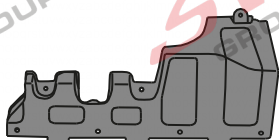
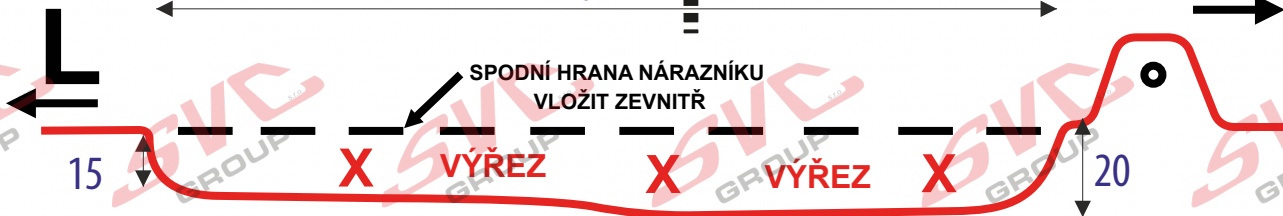

13.

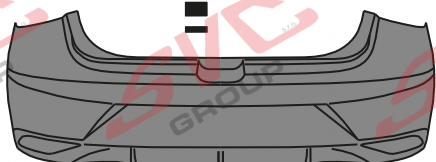
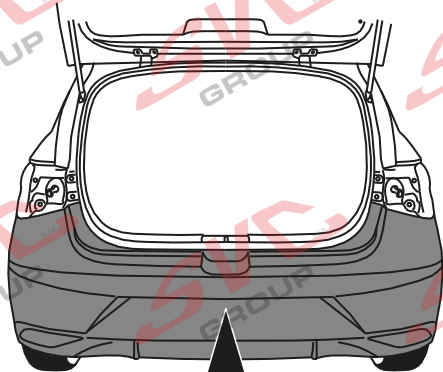

HYUNDAI BAYON

! DO NÁRAZNÍKU VLOŽIT ZRCADLOVĚ !

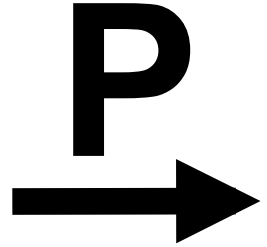
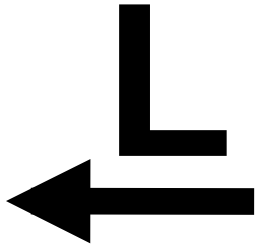

VÝŘEZ

1:1

**SOPODNÍ HRANA
NÁRAZNÍKU**

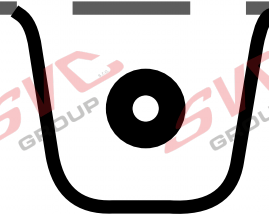

14.

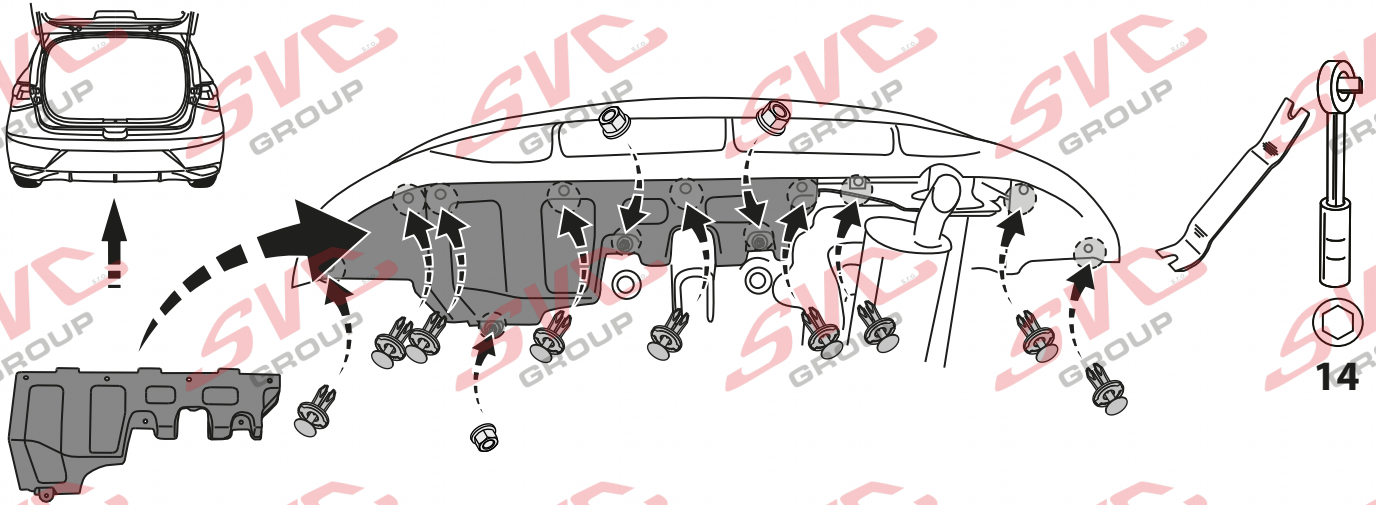

15.

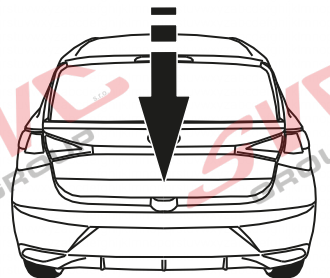
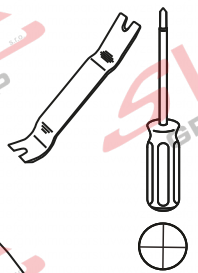
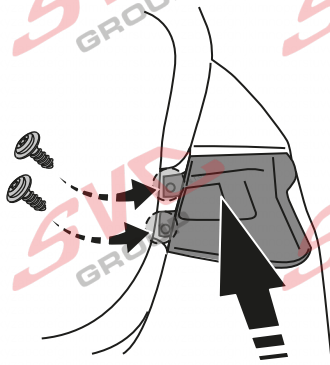
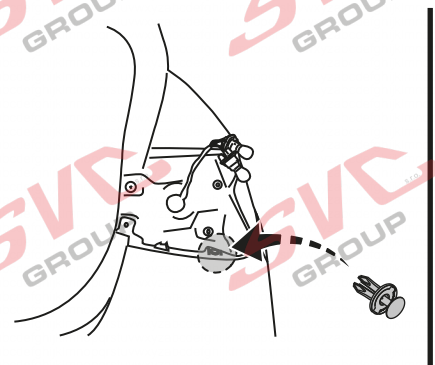
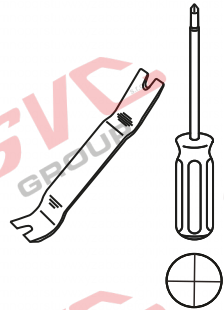
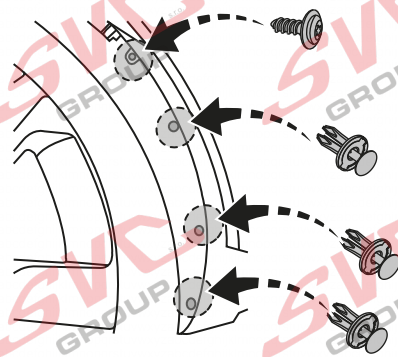
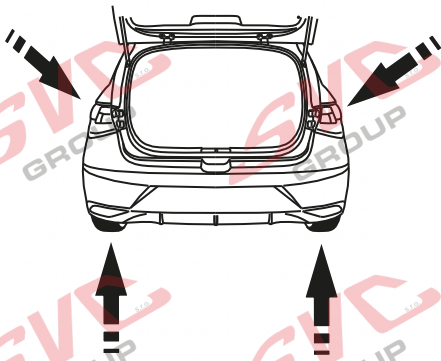

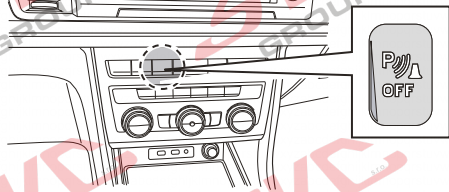
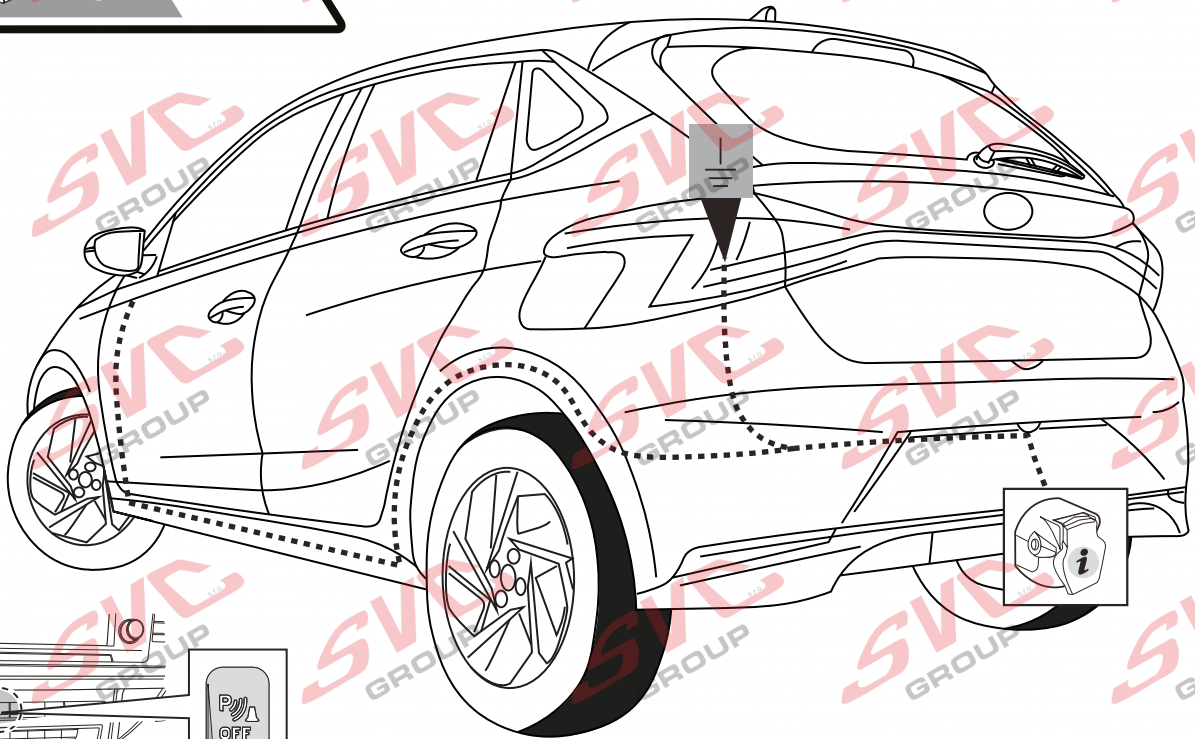

Informace pro odpojování couvacích senzorů PDC pro tažné zařízení

Vypínač pro vypínání couvacích senzorů PDC je umístěn na palubní desce vozu.

Nemusíte tedy pracně na elektro instalaci vozu napojovat odpojování couvacích senzorů PDC a zpětných kamer od elektro přípojky tažných zařízení.

Pokud chcete senzory vypnout, použijte vypínač na palubní desce.

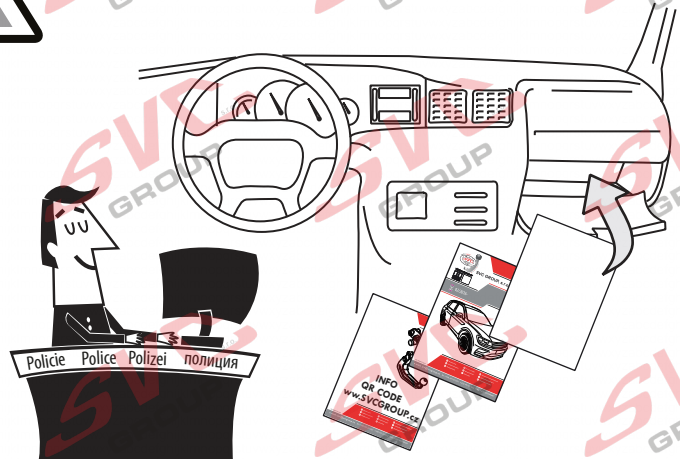
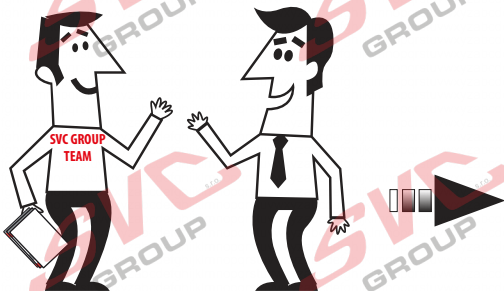

SVC GROUP

Děkuje za důvěru / Дакуюе за доверу еренти / Регистрация
T
Merci pour votre conance / Grazie per la tua ducia
Tankewol foar jo fertrouwen / Спасибо за ваще доверие

Registrace / Registrácia
Registration / Registrierung
Inscription / Registrazione thank you for your trust / Danke Für dein Vertrauen
Rekist



T-1

CZ Informace k provozu / homologaci

Výrobek je vyráběn dle platných norem EHK-55 R pro prodej ve státech EU. Informace pro použití, provoz a záruky pro tažné zařízení naleznete na našem webu, www.svcgroup.cz
Technické informace > Tažné zařízení > Všeobecné podmínky použití výrobku. Nebo si je stáhněte aplikace přes přiložený QR-cod
Součástí dodávky tažného zařízení je dodán TYPOVÝ LIST. Tento typový list slouží pro zapsání výrobku do technického průkazu vozidla, a obsahuje základní podmínky pro použití výrobku.
Typový list slouží i jako záruční lis proto jej uschovejte v dokumentaci vozidla.

SK Informácie na prevádzku / homologáciu

Výrobok je vyrábaný podľa platných noriem EHK-55 R pre predaj v štátoch EÚ. Informácie pre použitie, prevádzku a záruky pre ťažné zariadenie nájdete na našom webe, www.svcgroup.cz
Technické informácie > Ťažné zariadenie > Všeobecné podmienky použitia výrobku. Alebo si ich stiahnite aplikácie cez priložený QR-cod
Súčasťou dodávky ťažného zariadenia je dodaný TYPOVÝ LIST. Tento typový list slúži pre zapísanie výrobku do technického preukazu vozidla, a obsahuje základné podmienky použitia výrobku.
Typový list slúži aj ako záručný lis preto ho uschovajte v dokumentácii vozidla.

EN Operating / homologation information

The product is manufactured according to the applicable EHK-55 R standards for sale in EU countries. Information on the use, operation and warranties for the towbar can be found on our website, www.svcgroup.com
Technical information > Towing hitch > General conditions of use. Or download them via QR-cod
The towing device is supplied with a TYPE SHEET. This data sheet is used to enter the product in the vehicle registration document and contains the basic conditions for use of the product.
The data sheet also serves as a warranty press, so keep it in the vehicle documentation.

DE Betriebs / Zulassungsinformationen

Das Produkt wird gemäß den geltenden EHK-55 R-Standards für den Verkauf in EU-Ländern hergestellt. Informationen zu Verwendung, Betrieb und Gewährleistung der Anhängerkupplung finden Sie auf unserer Website www.svcgroup.com
Technische Informationen > Anhängerkupplung > Allgemeine Nutzungsbedingungen. Oder laden Sie sie per QR-Code herunter
Die Anhängervorrichtung wird mit einem TYPENBLATT geliefert. Dieses Datenblatt dient zur Eintragung des Produkts in das Kfz-Kennzeichen und enthält die Grundbedingungen für die Verwendung des Produkts. Das Datenblatt dient auch als Garantiepresse. Bewahren Sie es daher in der Fahrzeugdokumentation auf.

HU Üzemeltetési / homologációs információk

Das Produkt wird gemäß den geltenden EHK-55 R-Standards für den Verkauf in EU-Ländern hergestellt. Informationen zu Verwendung, Betrieb und Gewährleistung der Anhängerkupplung finden Sie auf unserer Website www.svcgroup.com
Technische Informationen > Anhängerkupplung > Allgemeine Nutzungsbedingungen. Oder laden Sie sie per QR-Code herunter
Die Anhängervorrichtung wird mit einem TYPENBLATT geliefert. Dieses Datenblatt dient zur Eintragung des Produkts in das Kfz-Kennzeichen und enthält die Grundbedingungen für die Verwendung des Produkts. Das Datenblatt dient auch als Garantiepresse. Bewahren Sie es daher in der Fahrzeugdokumentation auf.

FR Informations d'exploitation / homologation

Le produit est fabriqué conformément aux normes EHK-55 R applicables pour la vente dans les pays de l'UE. Des informations sur l'utilisation, le fonctionnement et les garanties de l'attelage sont disponibles sur notre site Web, www.svcgroup.com.
Informations techniques > Attelage de remorquage > Conditions générales d'utilisation. Ou téléchargez-les via QR-cod
Le dispositif de remorquage est fourni avec une feuille de type. Cette fiche technique est utilisée pour entrer le produit dans le certificat d'immatriculation du véhicule et contient les conditions de base pour l'utilisation du produit. La fiche technique sert également de presse de garantie, conservez-la dans la documentation du véhicule.

IT Informazioni sull'operazione / omologazione

Il prodotto è fabbricato secondo le norme EHK-55 R applicabili in vendita nei paesi dell'UE. Informazioni sull'uso, il funzionamento e le garanzie per il gancio di traino sono disponibili sul nostro sito Web www.svcgroup.com
Informazioni tecniche > Gancio di traino > Condizioni generali d'uso. Oppure scaricali tramite QR-cod
Il dispositivo di rimorchio viene fornito con una SCHEDA TIPO. Questa scheda tecnica viene utilizzata per inserire il prodotto nel certificato di immatricolazione del veicolo e contiene le condizioni di base per l'uso del prodotto. La scheda tecnica funge anche da presa di garanzia, quindi conservala nella documentazione del veicolo.



SVC GROUP s.r.o.

Průmyslová zóna - 179

www.svcgroup.cz

Tel.: +420 491 421 021

+420 491 421 022

547 01 Náchod-ČR

e-mail: svc@svcgroup.cz

mob.: +420 603360607

ti a kibővített összeszerelési utasításokat

SVC GROUP ©- 05/19



Hyundai i20
Hyundai BAYON



09/2020 ->>
06/2021 ->>



09/6022



1500/85 D=7,64



55R-01-0581



1,5->2,0 h



VTZ 1.001-514 14,20



A-514-2021



VTZ 1.002-514 15,20



V-514-2021



VTZ 1.003-514 16,20



AV-515-2021

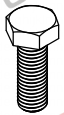
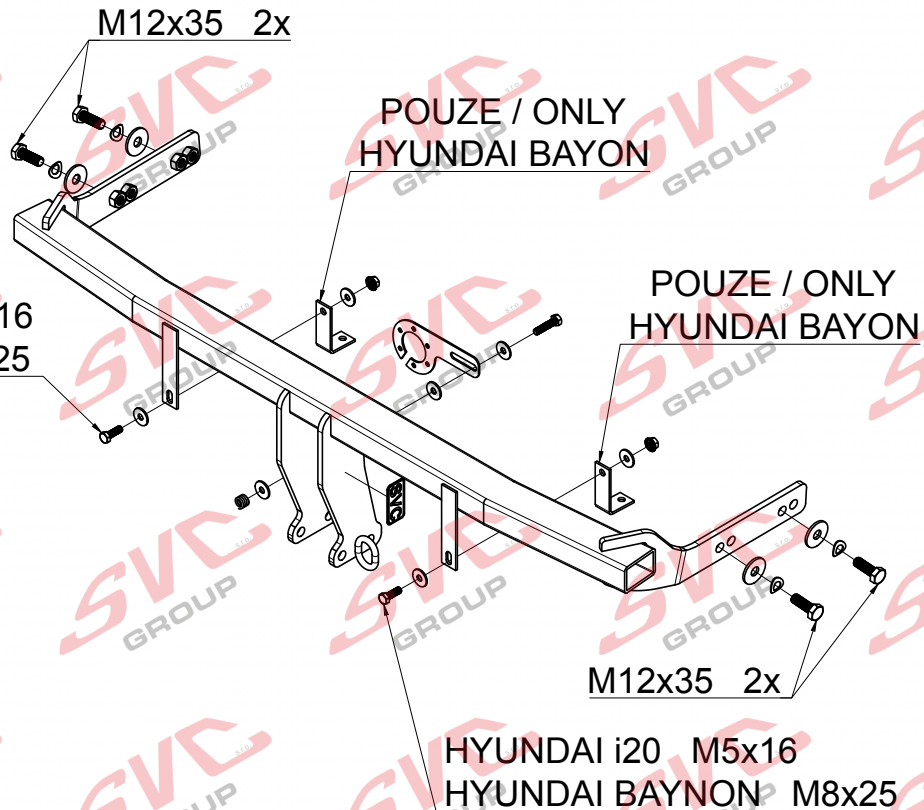

M12x35	4x	
M8x25	2x	HYUNDAI BAYON
M5x16	2x	HYUNDAI i20



Ø12 4x



Ø12	4x	
Ø8	4x	HYUNDAI BAYON
Ø5	4x	HYUNDAI i20



M8	2x	HYUNDAI BAYON
M5	2x	HYUNDAI i20

HYUNDAI BAYON

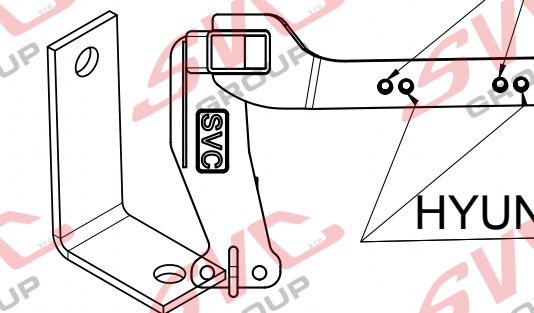



NL Monteringsanvisningar

Het product is vervaardigd volgens de toepasselijke EHK-55 R-normen voor verkoop in EU-landen. Informatie over het gebruik, de werking en de garanties voor de trekhaak vindt u op onze website, www.svcgroup.com *Technische informatie* > *Trekhaak* > *Algemene gebruiksvoorwaarden*. Of download ze via QR-cod
Het sleepapparaat wordt geleverd met een TYPE BLAD. Dit gegevensblad wordt gebruikt om het product in het voertuigregistratiedocument in te voeren en bevat de basisvoorwaarden voor het gebruik van het product. Het gegevensblad dient ook als garantiepers, dus bewaar het in de voertuigdocumentatie.

ES Instrucciones de montaje

El producto se fabrica de acuerdo con los estándares EHK-55 R aplicables para la venta en países de la UE. Puede encontrar información sobre el uso, el funcionamiento y las garantías de la barra de remolque en nuestro sitio web, www.svcgroup.com *Información técnica* > *Enganche de remolque* > *Condiciones generales de uso*. O descárguelos a través de QR-cod
El dispositivo de remolque se suministra con una HOJA DE TIPO. Esta hoja de datos se utiliza para ingresar el producto en el documento de registro del vehículo y contiene las condiciones básicas para el uso del producto. La hoja de datos también sirve como una prensa de garantía, por lo tanto, consérvela en la documentación del vehículo.

FIN Montage-instructie

Tuote on valmistettu EU-maissa myytävien EHK-55 R -standardien mukaisesti. Tietoja vetokoukun käytöstä, käytöstä ja takuista löytyy verkkosivuiltamme www.svcgroup.com *Tekniset tiedot* > *Vetokoukku* > *Yleiset käyttöolosuhteet*. Tai lataa ne QR-koodin kautta
Hinauslaite toimitetaan TYYPPI-ARKKI. Tätä lomaketta käytetään tuotteen syöttämiseen ajoneuvon rekisteröintitodistukseen, ja se sisältää tuotteen käytön perusedellytykset. Tietolomake toimii myös takuupuristimena, joten säilytä se ajoneuvon dokumenteissa.



Izdelek je izdelan po veljavnih standardih EHK-55 R za prodajo v državah EU. Informacije o uporabi, delovanju in garancijah za vlečno ploščo najdete na našem spletnem mestu www.svcgroup.com *Tehnični podatki* > *Vlečna kljuka* > *Splošni pogoji uporabe*. Ali pa jih prenesite preko QR-kod
Vlečna naprava je opremljena s TIPNIM LISTOM. Ta podatkovni list se uporablja za vnos izdelka v registracijski dokument vozila in vsebuje osnovne pogoje za uporabo izdelka. Podatkovni list služi tudi kot garancijski tisk, zato ga hranite v dokumentaciji vozila.

NOR Drifts- / homologasjonsinformasjon

Produktet er produsert i henhold til gjeldende EHK-55 R standarder for salg i EU-land. Informasjon om bruk, drift og garantier for tilhengerfeste finner du på vår hjemmeside, www.svcgroup.com *Teknisk informasjon* > *Tilhengerfeste* > *Generelle bruksbetingelser*. Eller last dem ned via QR-koding
Tøeanordningen leveres med TYPEBLAD. Dette databladet brukes til å oppgi produktet i kjøretøyets registreringsbevis og inneholder de grunnleggende betingelsene for bruk av produktet. Databladet fungerer også som garantipresse, så hold det i bilens dokumentasjon.

PL Informacje dotyczące pracy / homologacji

Produkt jest wytwarzany zgodnie z obowiązującymi normami EHK-55 R na sprzedaż w krajach UE. Informacje na temat użytkowania, obsługi i gwarancji na hak holowniczy można znaleźć na naszej stronie internetowej www.svcgroup.com *Informacje techniczne* > *Żaczep holowniczy* > *Ogólne warunki użytkowania*. Lub pobierz je za pomocą kodu QR
Urządzenie holownicze jest dostarczane z ARKUSZEM TYPU. Ta karta danych służy do wpisania produktu do dokumentu rejestracyjnego pojazdu i zawiera podstawowe warunki użytkowania produktu. Karta danych służy również jako prasa gwarancyjna, dlatego przechowuj ją w dokumentacji pojazdu.

RU Информация о работе /омологации

de la barra de remolque en nuestro sitio web, www.svcgroup.com *Información técnica* > *Enganche de remolque* > *Condiciones generales de uso*. O descárguelos a través de QR-cod
El dispositivo de remolque se suministra con una HOJA DE TIPO. Esta hoja de datos se utiliza para ingresar el producto en el documento de registro del vehículo y contiene las condiciones básicas para el uso del producto. La hoja de datos también sirve como una prensa de garantía, por lo tanto, consérvela en la documentación del vehículo.



QR k

SVC GROUP s.r.o.

Průmyslová zóna - 179
547 01 Náchod-ČR

www.svcgroup.cz
e-mail: svc@svcgroup.cz

Tel.: +420 491 421 021
+420 491 421 022
mob.: +420 603 360 607
SVC GROUP ©- 05/19



Hyundai i20
Hyundai BAYON



09/2020 ->>
06/2021 ->>

N-1

ES Manual de montaje

Para obtener instrucciones detalladas de instalación y condiciones del producto, escanee el código QR

1. Desmonte los focos traseros, parachoques con su refuerzo plástico y aje los guardabarros interiores.
2. Inserte el equipo de tiro por atrás en los soportes y je con 4 tornillos M12x35 con arandelas grandes. Enderece el equipo de tiro y apriete según los pares de apriete.
3. Desmonte el refuerzo plástico del parachoques (éste no hará falta más). Desmonte de él los soportes plásticos inferiores de los parachoques montándolos en el equipo de tiro por medio de 2 tornillos M5x16. Sujete la instalación eléctrica del refuerzo en el parachoques con cintas plásticas.
4. Haga un recorte la cubierta plástica inferior y en el parachoques según la gura. Monte de vuelta todas las piezas desmontadas según el punto No. 1.

IT Istruzioni di montaggio per la

Per istruzioni di installazione dettagliate e condizioni del prodotto, eseguire la scansione del codice

1. Smontare i fanali posteriori ed il paraurti con il suo rinforzo in plastica e allentare rivestimento di plastica sopra le ruote.
2. Nei supporti inserire da dietro il dispositivo di traino ssandolo con 4 bulloni M12x35 con rondelle di grandi dimensioni. Allineare il dispositivo di traino e serrare con le coppie di serraggio prescritte.
3. Smontare il rinforzo in plastica dal paraurti (non sarà più necessario). Dal rinforzo smontare i portapaurti inferiori a montare sul dispositivo di traino usando 2 bulloni M5x16. Fissare l'installazione elettrica al paraurti usando fascette in plastica.
4. Fare un intaglio nel pezzo plastico inferiore di copertura e nel paraurti, vedi gura. Rimontare tutti i componenti smontati nel punto 1.

NO Monteringsanvisning

For installasjonsinstruksjoner og produktbetingelser, skann QR-koden

1. Demontér baklys og støtfanger, inkl. dennes plastforsterkning, og løsne på plastdelen over hjulene.
2. Stikk trekkutstyret inn i bæreelementene bakfra og fest ved hjelp av re skruer av typen M12x35 med underlag med store ater. Justér trekkutstyret og stram slik tiltrekningsmomentene foreskriver
3. Demontér plastforsterkningen fra støtfangeren (du vil ikke behøve den mer). Fra denne demonterer du plastholderne nede på støtfangerne og monterer dem til trekkutstyret ved hjelp av to skruer av typen M5x16. Fest det elektriske anlegget fra forsterkningen til støtfangeren ved hjelp av plaststrips.
4. Lag en åpning inn i den dekkende plastdelen nede og i støtfangeren slik illustrasjonen viser. Montér på plass igjen alle de delene som ble demontert i punkt 1.

NL Montagehandleiding

Scan de QR-code voor installatie-instructies en instructies voor productcondities

1. Demonteer de achterlichten en de bumper met zijn kunststof versterking en maak de kunststof wielkasten los.
2. Schuif de trekrichting van achteren in de draagbalken en bevestig met 4 M12x35 bouten met grote sluitringen. Lijn de trekrichting uit en draai aan conform de draaimomenten.
3. Haal de kunststof versterking uit de bumper (deze is niet meer nodig). Verwijder hieruit de onderste kunststof bumpersteunen en monteer deze met 2 M5x16 bouten op de trekrichting. Bevestig de bedrading uit de versterking aan de bumper met tiwrraps.
4. Maak een uitsparing in de onderste kunststof behuizing en in de bumper zoals op de afbeelding. Plaats de in punt 1 gedemonteerde onderdelen terug.

HU Szerelési útmutató

A telepítési és a termékfeltételekkel kapcsolatos utasításokat olvassa be a QR-kódot

1. Szerelje le a hátsó lámpákat, lökhárítót és ennek műanyag erősítését, és oldja ki a műanyag kerékíveket.
2. Hátról illeszse be a vonóhorogot a tartóba, és rögzítse 4db M12x35 csavarral a nagy felületű alátéteken át. Egyenesítse ki és húzza meg a vontatóberendezést a meghúzási nyomaték szerint.
3. Távolítsa el a lökhárító műanyag erősítését (erre már nem lesz szüksége), ebből távolítsa el az alsó műanyag lökhárító tartókat és szerelje fel a vonószerkezetre 2 db M5x16 csavar segítségével. Rögzítse az elektromos szerelést a merevítéstől a lökhárítóig műanyag hevederekkel.
4. Az ábra szerint vágjon ki egy rést az alsó műanyag burkolatába és a lökhárítóba. Helyezze vissza az 1. lépésben eltávolított alkatrészeket.

RU Инструкция по монтажу

Подробные инструкции по установке и условиям продукта отсканируйте QR-к

1. Снимите задние фонари, бампер и его пластиковый усилитель, и освободите пластиковые надколесные дуги.
2. Сзади вставьте в балки фаркоп и закрепите 4 болтами M12x35 с увеличенными шайбами. Выровняйте фаркоп и затяните в соответствии с предписанными моментами затяжки.
3. Извлеките пластиковый усилитель бампера (он больше не потребуется), снимите с него нижние пластиковые держатели бамперов и установите на фаркоп с помощью 2 болтов M5x16. Электрику из усилителя закрепите на бампере с помощью пластиковых хомутов.
4. Сделайте вырез в нижней пластиковой крышке и бампере в соответствии с изображением. Установите обратно все части, демонтированные согласно п. 1.

SL Navodila za montažo

Za podrobna navodila za namestitvev in pogoje izdelka preberite kodo QR

1. Demontirajte zadnje luči, odbijač in tudi njegovo plastično ojačitev ter zrahljajte plastične kolesne loke.
2. Vlečno kljuko vstavite od zadaj v nosilce, pritrđite pa jo s pomočjo 4 vijakov M12x35 in širokih podložk. Poravnajte in zategnite vlečno kljuko glede na zatezne momente
3. Z odbijača odstranite plastično ojačitev (le-ta ne bo več potrebna). Nato pa odstranite spodnji plastični držali odbijačev in z 2 vijakoma M5x16 namestite na vlečno kljuko. Električno napeljavo ojačitve pritrđite na odbijač s plastičnimi trakovi.
4. Naredite izrez v spodnjem plastičnem pokrovu in odbijaču, kot je prikazano na sliki. Vse dele, demontirane v točki št. 1, montirajte nazaj.

SVC GROUP s.r.o.

Průmyslová zóna - 179
547 01 Náchod-ČR

www.svcgroup.cz
e-mail: svc@svcgroup.cz

Tel.: +420 491 421 021
+420 491 421 022
mob.: +420 603 360 607

SVC GROUP ©- 05/19

QR kódom stáhnete rozšířeny montážní návod / Verwenden Sie den QR-Code, um die erweiterte Montageanleitung herunterzuladen



- CZ** Pozor informace k záruce
- SK** Pozor informácie k záruke
- EN** Note the warranty information
- DE** Beachten Sie die Garantieinformationen

- HU** Vegye gyelembe a jótállási információkat
- FR** Notez les informations de garantie
- IT** Nota le informazioni sulla garanzia
- NL** Let op de garantie-informatie

- ES** Atención
- FIN** Huomio
- PL** Uwaga
- RU** Внимание

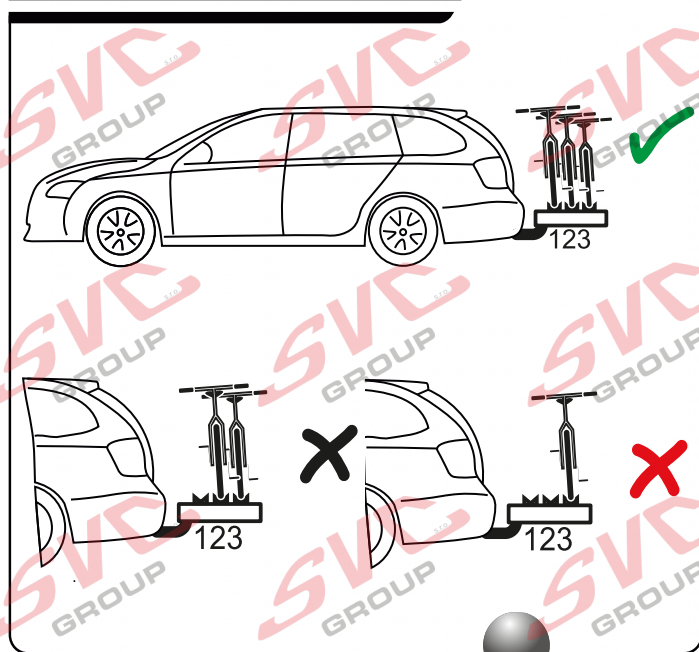
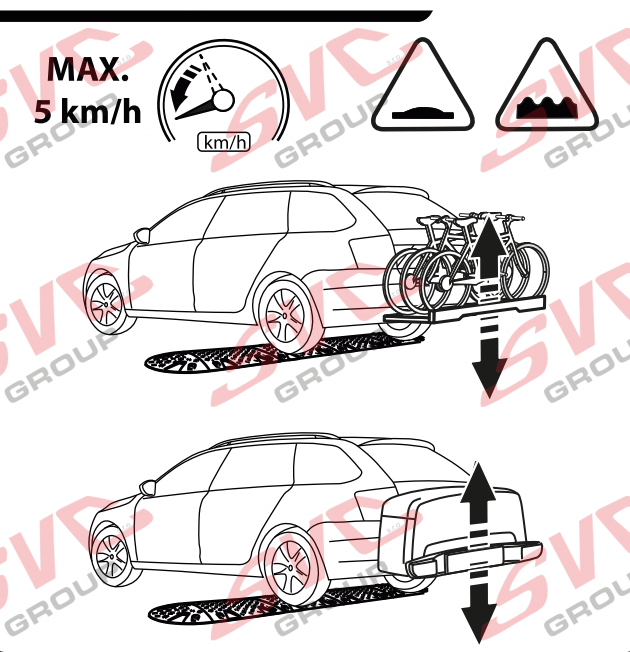
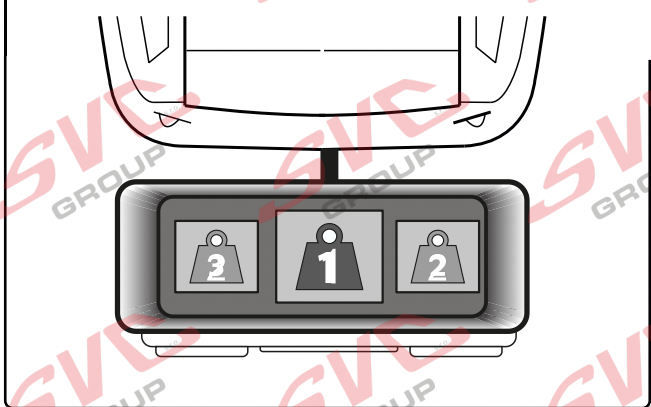
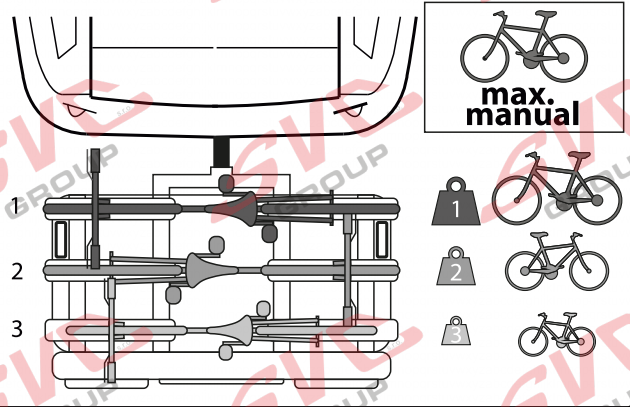
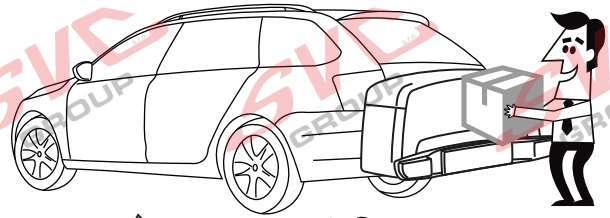
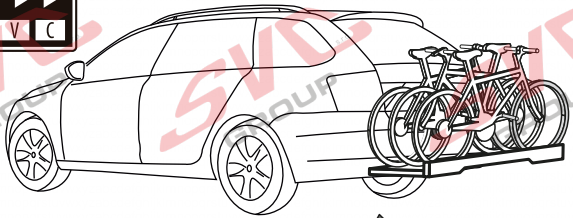

Vysokov 179
547 01 Náchod, Česká Republika

+420 603 360 607 +420 491421021



www.svcgroup.cz

Service Vítver Centrum



CZ Pozor informace k záruce
SK Pozor informácie k záruke
EN Note the warranty information
DE Beachten Sie die Garantieinformationen

HU Vegye gyelembe a jótállási információkat
FR Notez les informations de garantie
IT Nota le informazioni sulla garanzia
NL Let op de garantie-informatie

ES Atención
FIN Huomio
PL Uwaga
RU Внимание

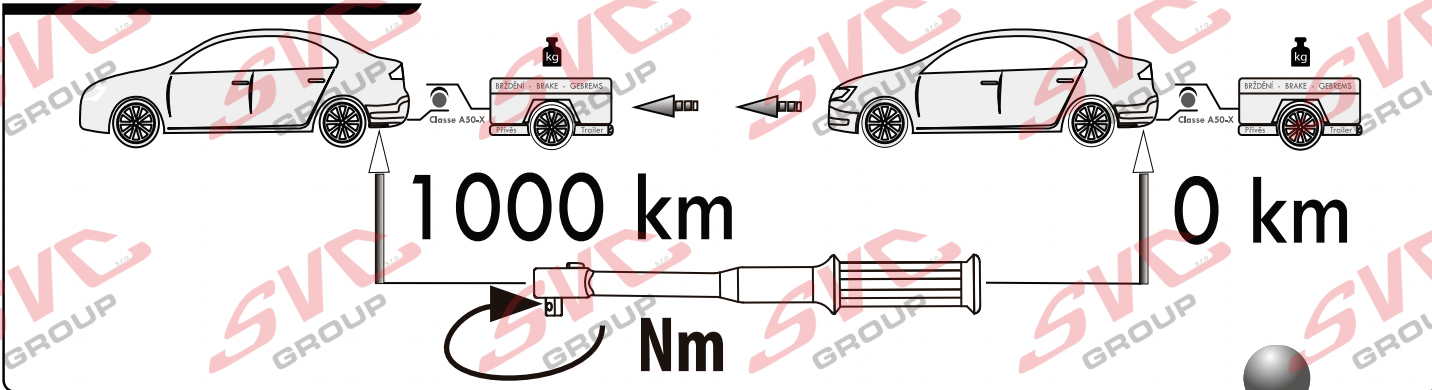
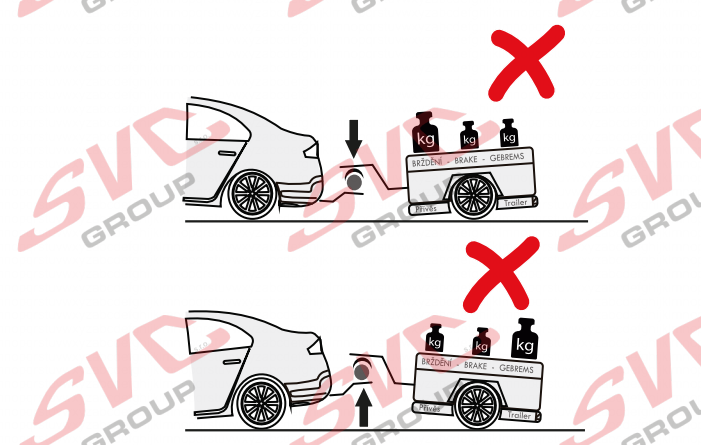
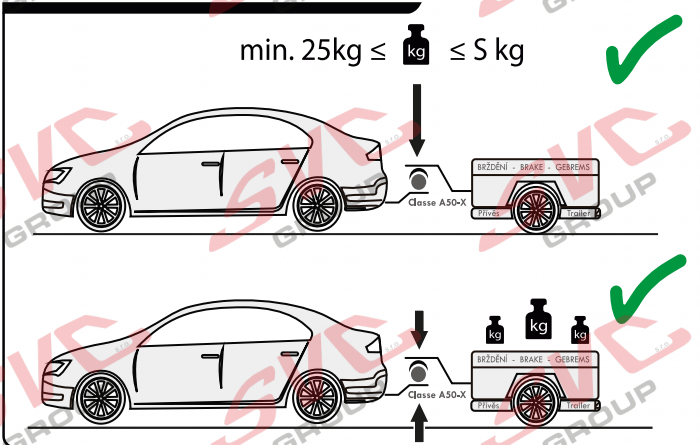
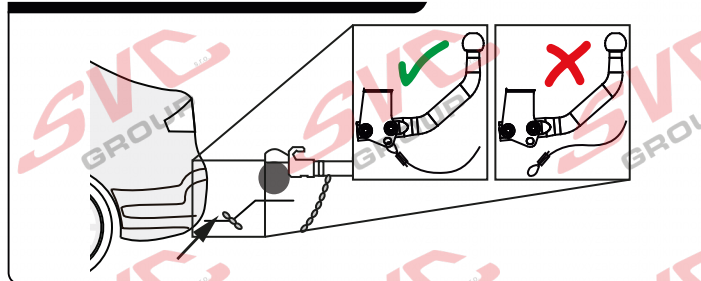
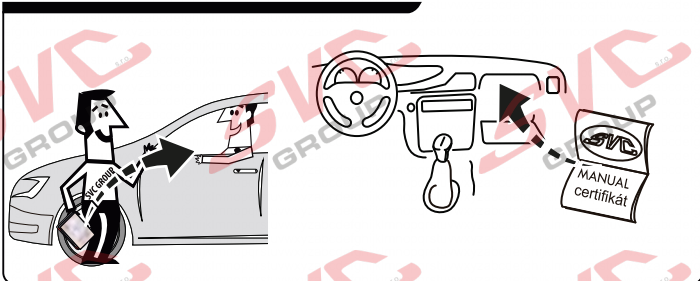
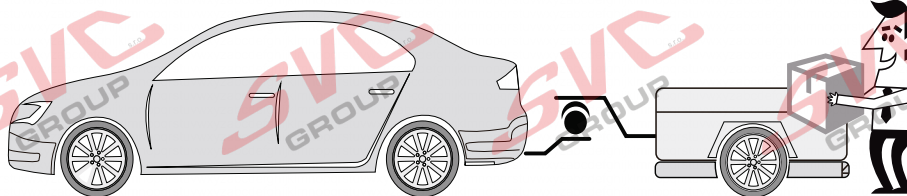

Vysokov 179
 547 01 Náchod, Česká Republika

+420 603 360 607 +420 491421021





CZ Pozor informace k záruce
SK Pozor informácie k záruke
EN Note the warranty information
DE Beachten Sie die Garantieinformationen

HU Vegye gyelembe a jótállási információkat
FR Notez les informations de garantie
IT Nota le informazioni sulla garanzia
NL Let op de garantie-informatie

ES Atención
FIN Huomio
PL Uwaga
RU Внимание

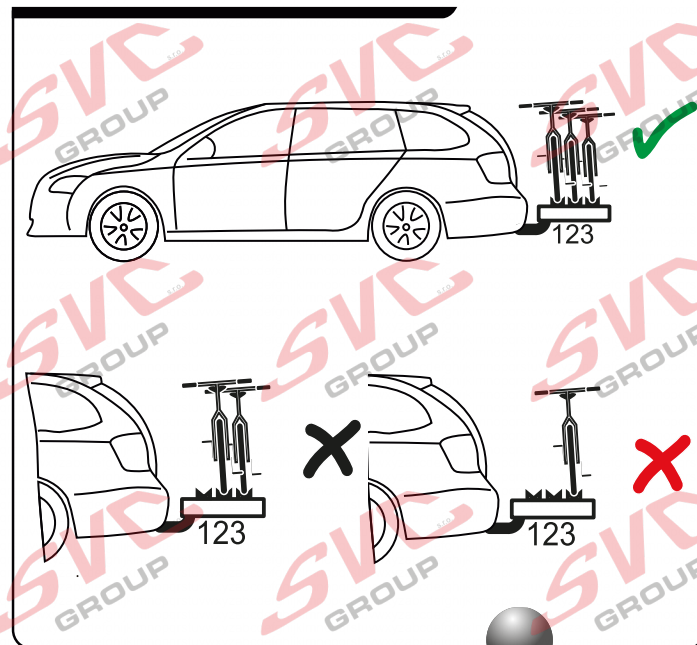
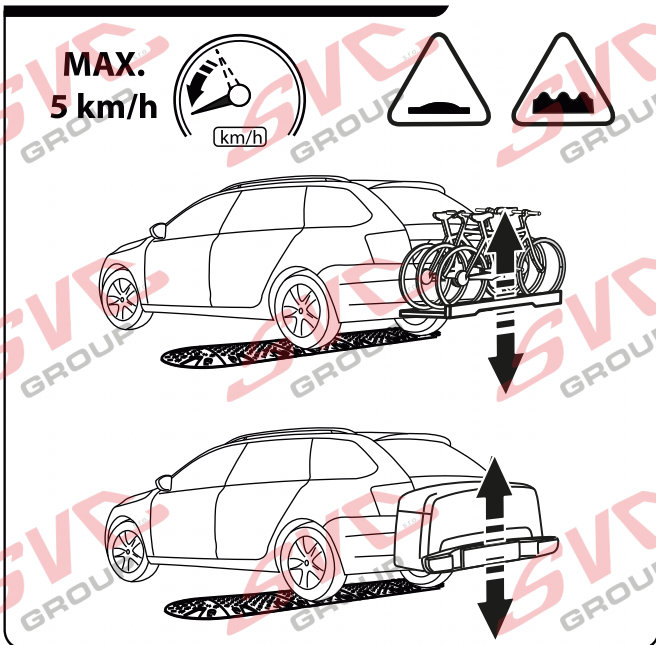
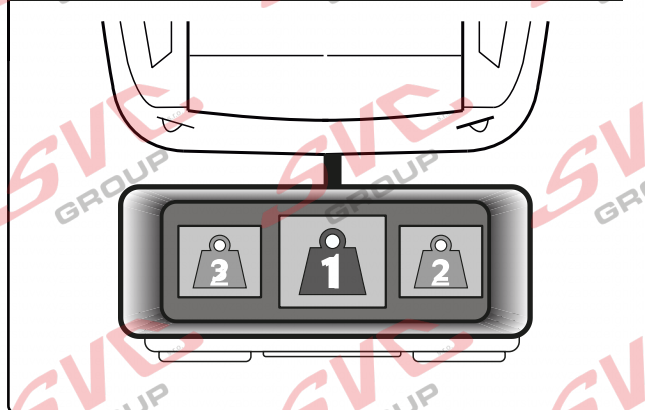
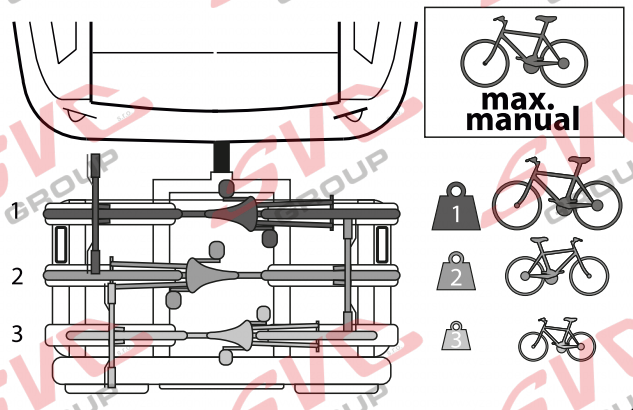
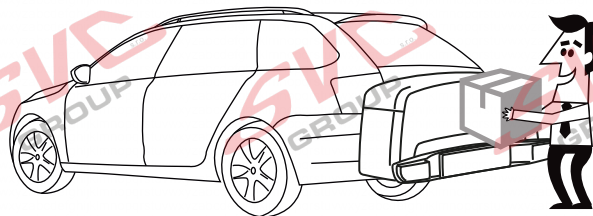
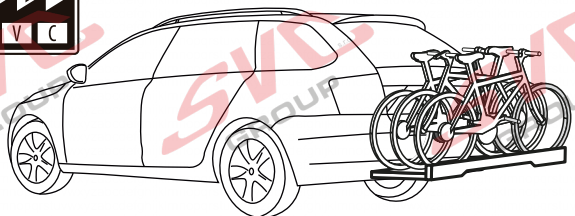

Vysokov 179
 547 01 Náchod, Česká Republika

+420 603 360 607 +420 491421021



www.svcgroup.cz

Service V itver C entrum

Nevíte si rady? Potřebujete poradit?

Náš zákaznický servis je vám k dispozici

 +420 491 421 021

 svc@svcgroup.cz



Opravdový specialista a Certifikovaný výrobce tažných zařízení s největším sortimentem v ČR. Rodinná firma s více jak 30letou ověřenou tradicí výroby, prodeje a montáže.

www.svcgroup.cz