

ERICH JAEGER

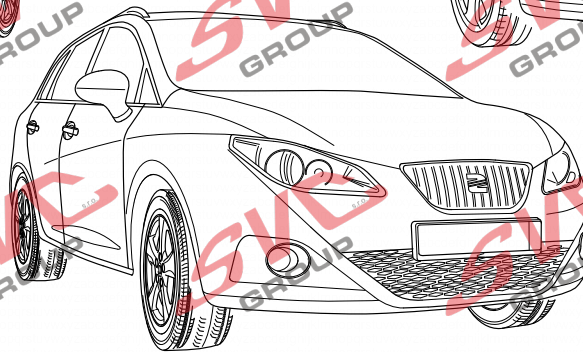
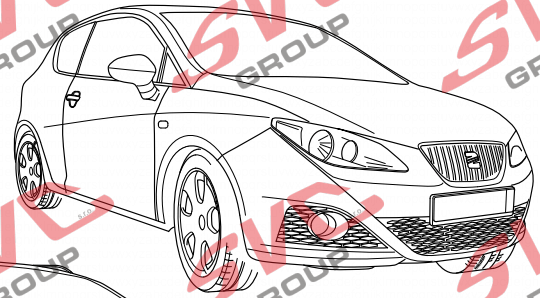
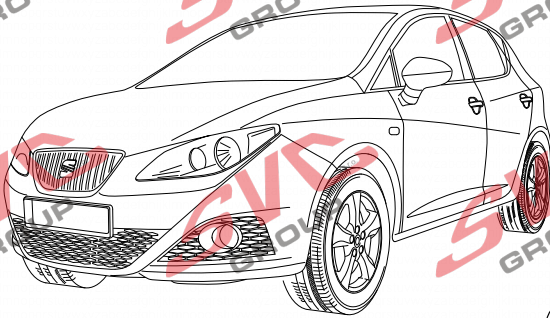

**SEAT Ibiza SC 3-door**

**SEAT Ibiza 5-door**

**SEAT Ibiza ST**

**06/08 >> 05/15**

**06/08 >> 05/15**

**06/10 >> 05/15**

**748313**

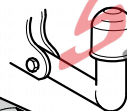
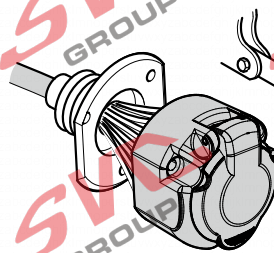

**13-PIN**

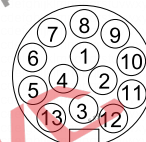

**ISO 11446**

- (D)** Einbauanleitung
- (GB)** Installation instructions
- (F)** Consignes de montage
- (NL)** Montagehandleiding
- (DK)** Montagevejledning
- (N)** Monteringsinstruksjon
- (S)** Installationsanvisning
- (FIN)** Asennusohje
- (I)** Istruzioni per il montaggio
- (E)** Instrucciones de montaje
- (P)** Instruções de montagem
- (GR)** Οδηγίες εγκατάστασης
- (CZ)** Návod k montáži

- (PL)** Instrukcja montażu
- (TR)** Montaj talimatı
- (H)** Beépítési útmutató
- (HR)** Upute o ugradnji
- (BUL)** Инструкция за монтаж
- (RO)** Instrucțiuni de montaj
- (RU)** Инструкция по монтажу и установке
- (LT)** Montavimo informacija
- (LV)** Iemontēšanas pamācība
- (EST)** Paigaldusjuhend
- (SLO)** Navodilo za vgradnjo
- (SK)** Montážny návod

# OVERVIEW

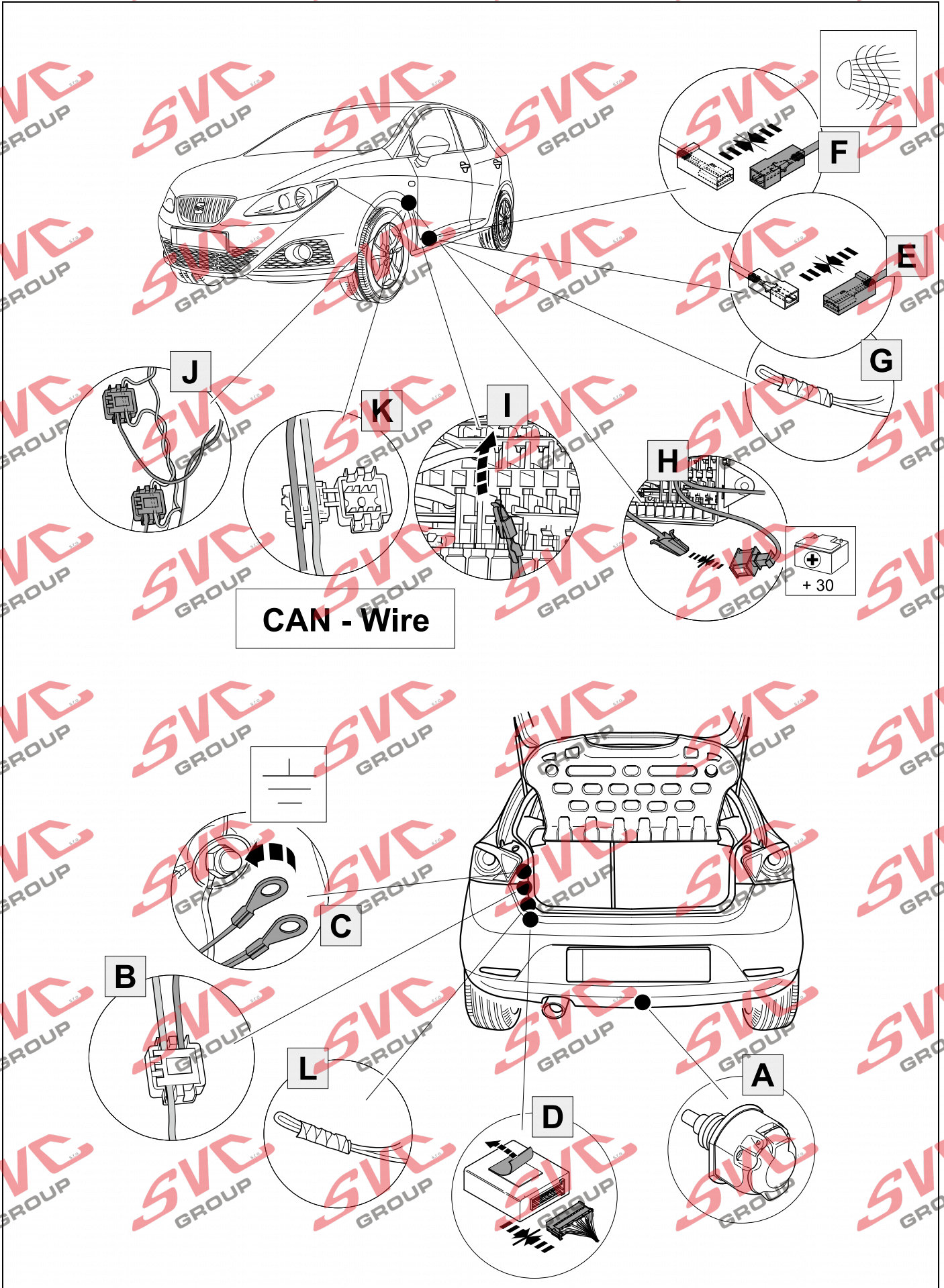



# KIT

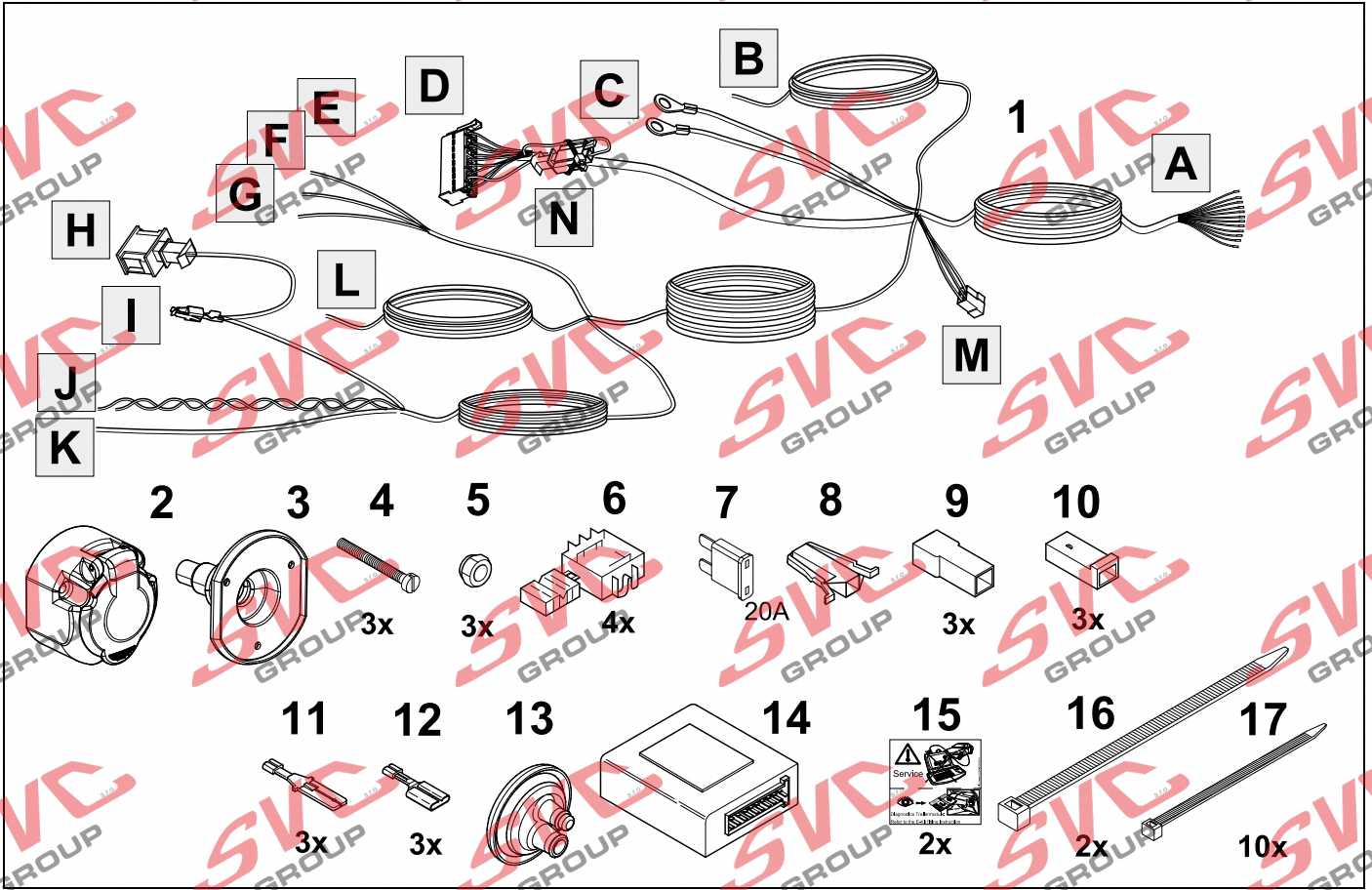

# TOOLS

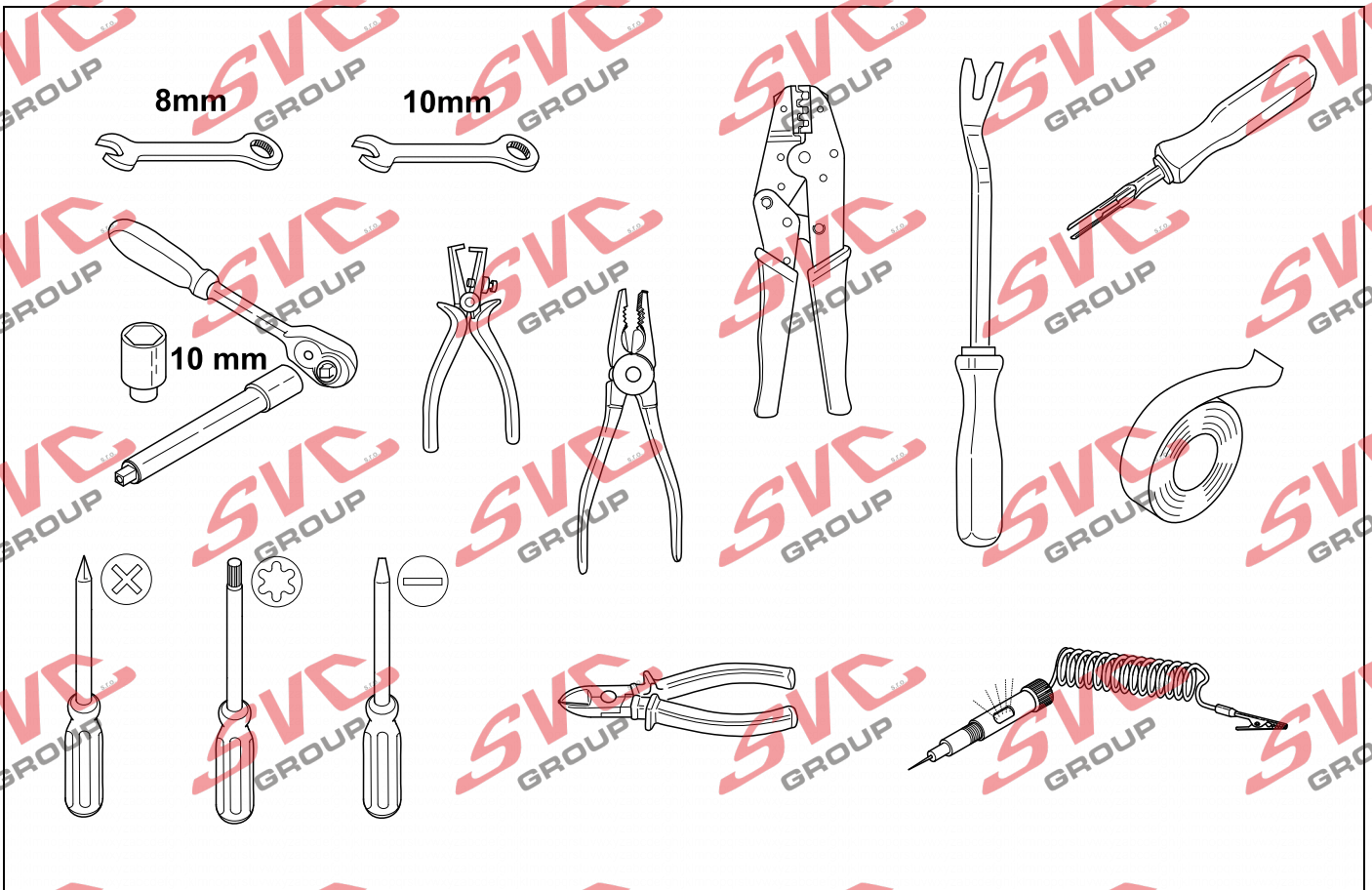

1.

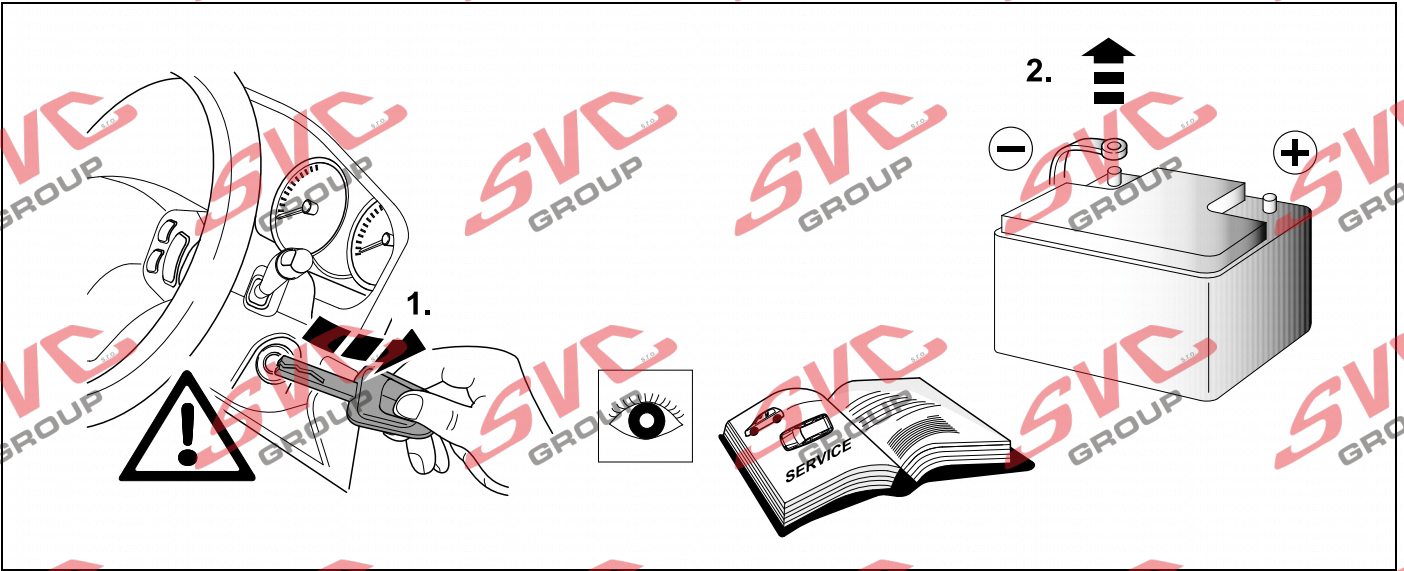

## 2 REMOVE

Ibiza 3-door/Ibiza 5-door

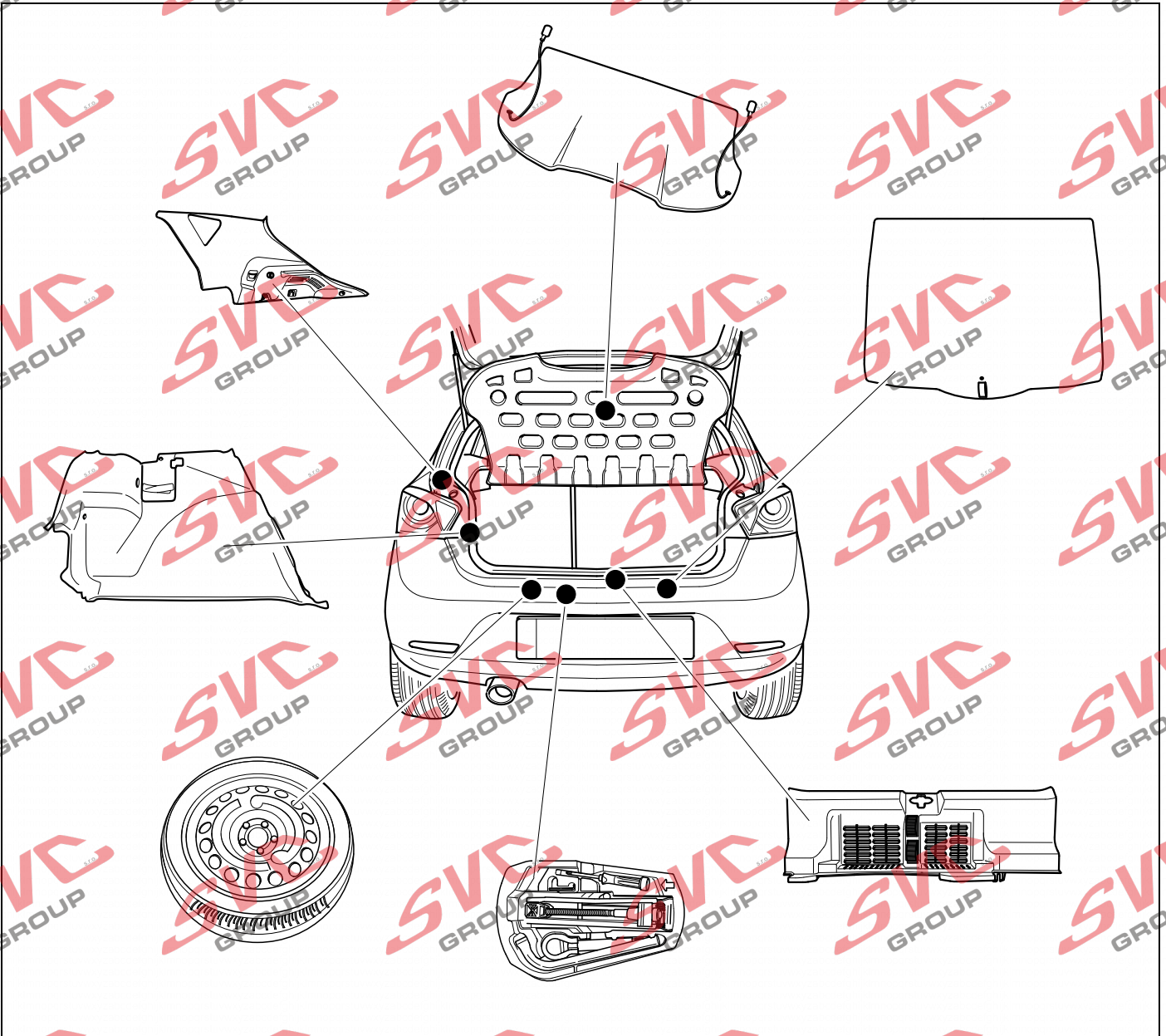



### 3 REMOVE

Ibiza ST

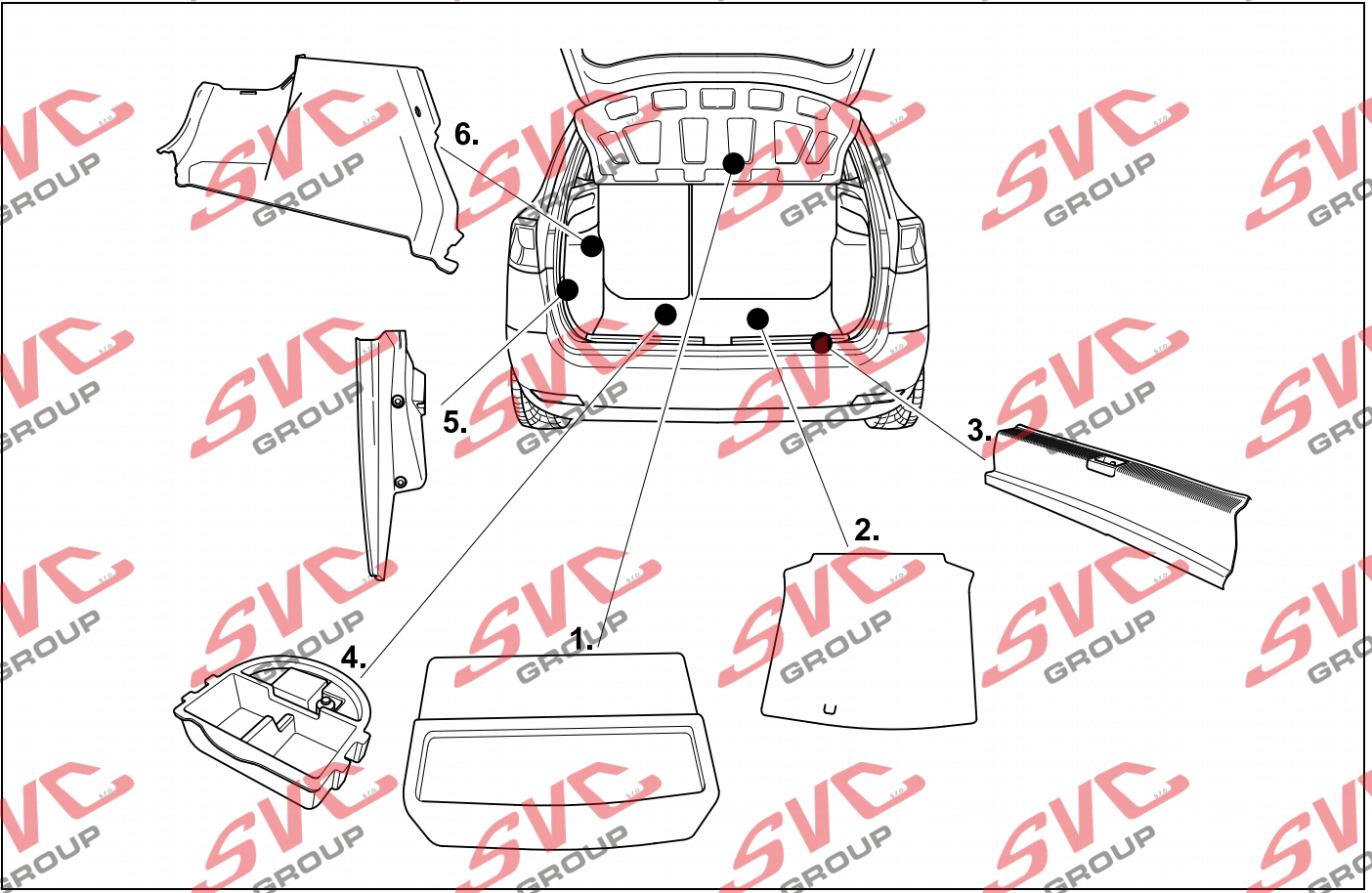

### 4

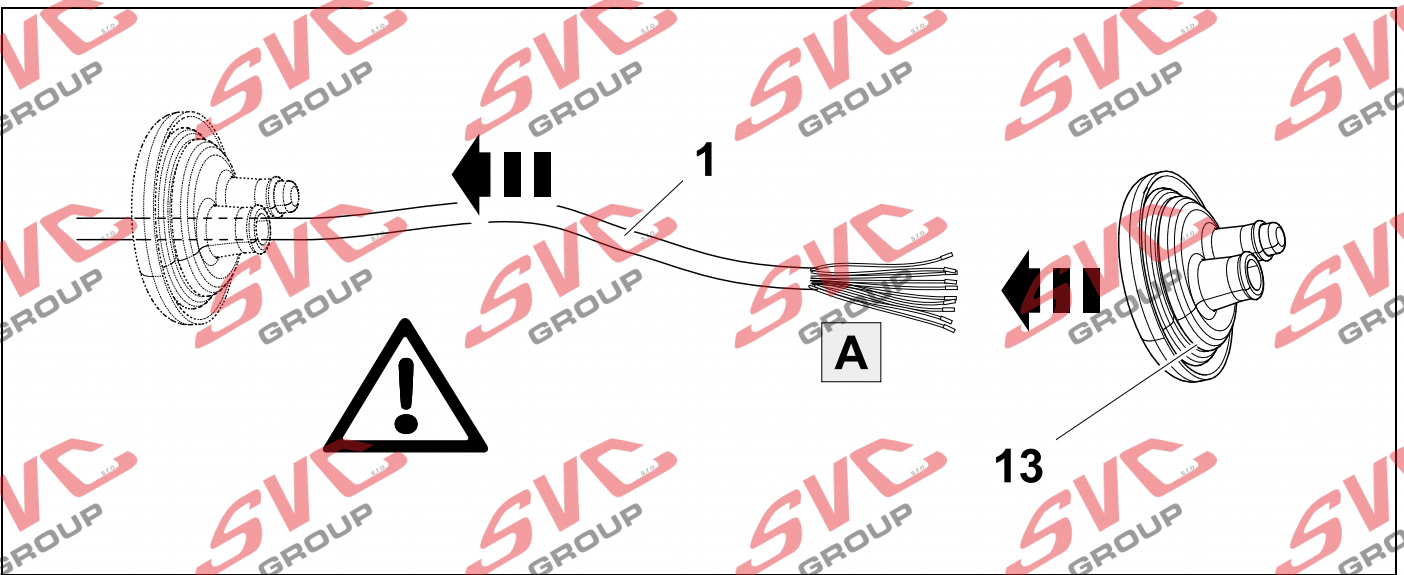

## 5 OPTION 1

Ibiza 3-door/Ibiza 5-door

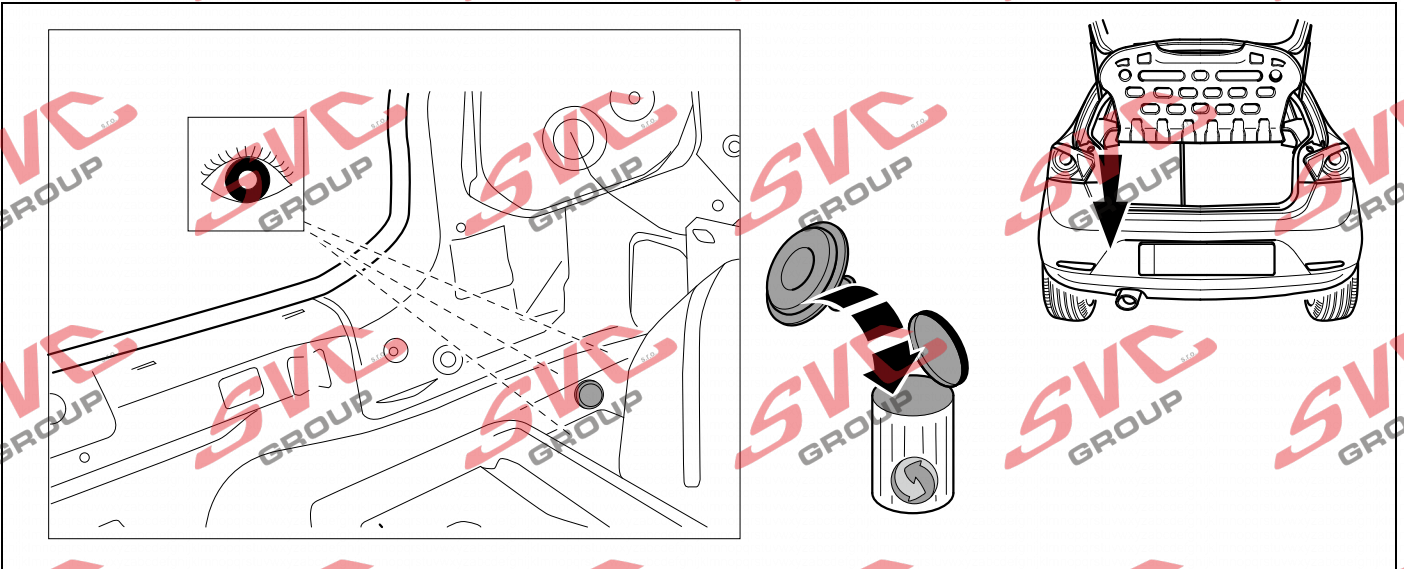

## 6 OPTION 2

Ibiza 3-door/Ibiza 5-door

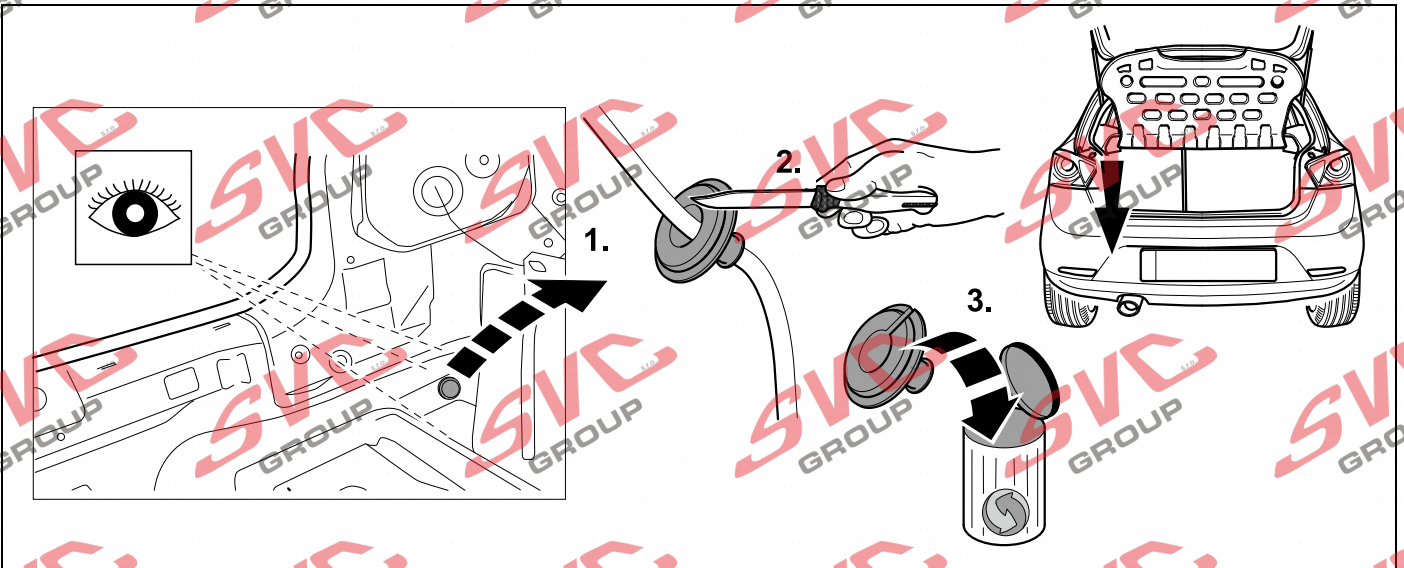



## 7 OPTION 2

Ibiza 3-door/Ibiza 5-door

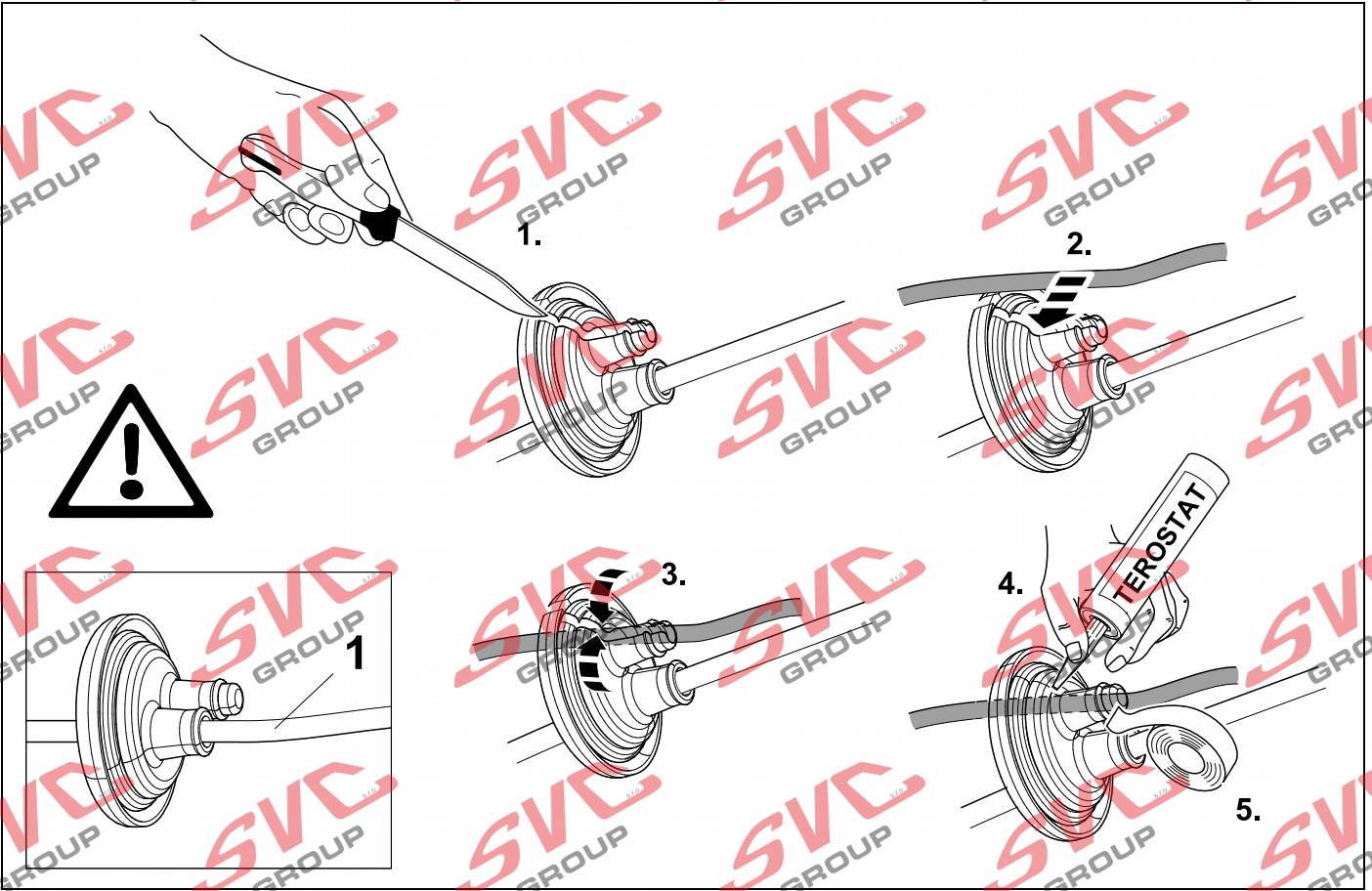

## 8 OPTION 3

Ibiza 3-door/Ibiza 5-door

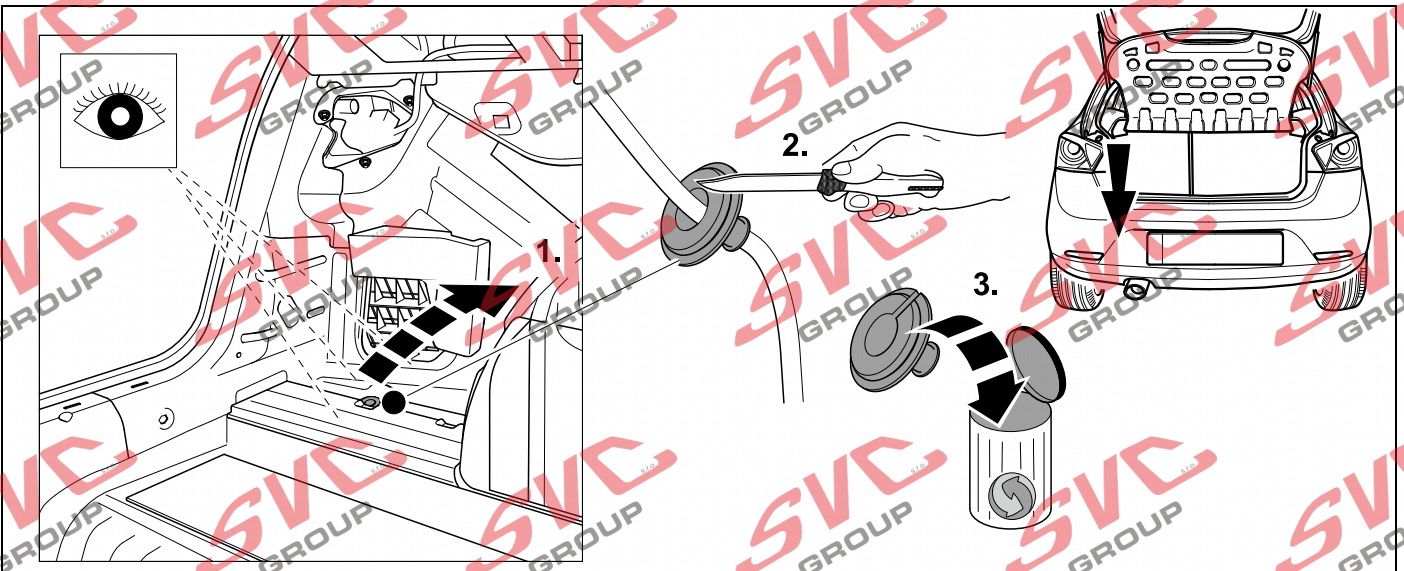

# 9 OPTION 1

Ibiza ST

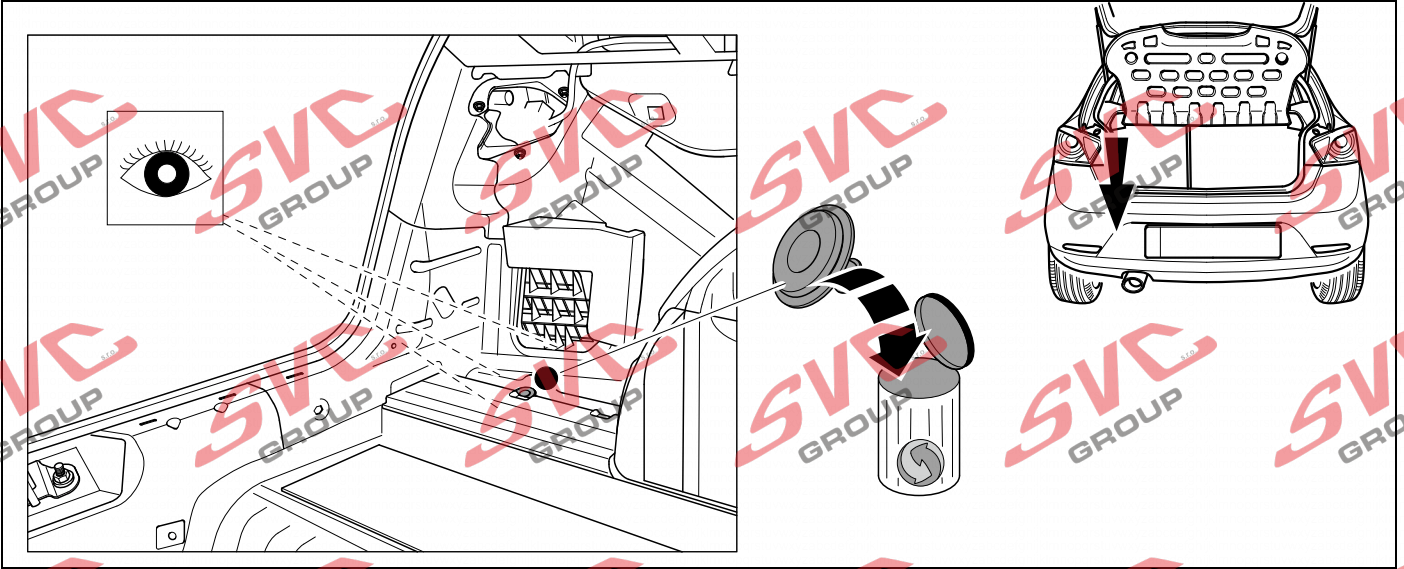

# 10 OPTION 2

Ibiza ST

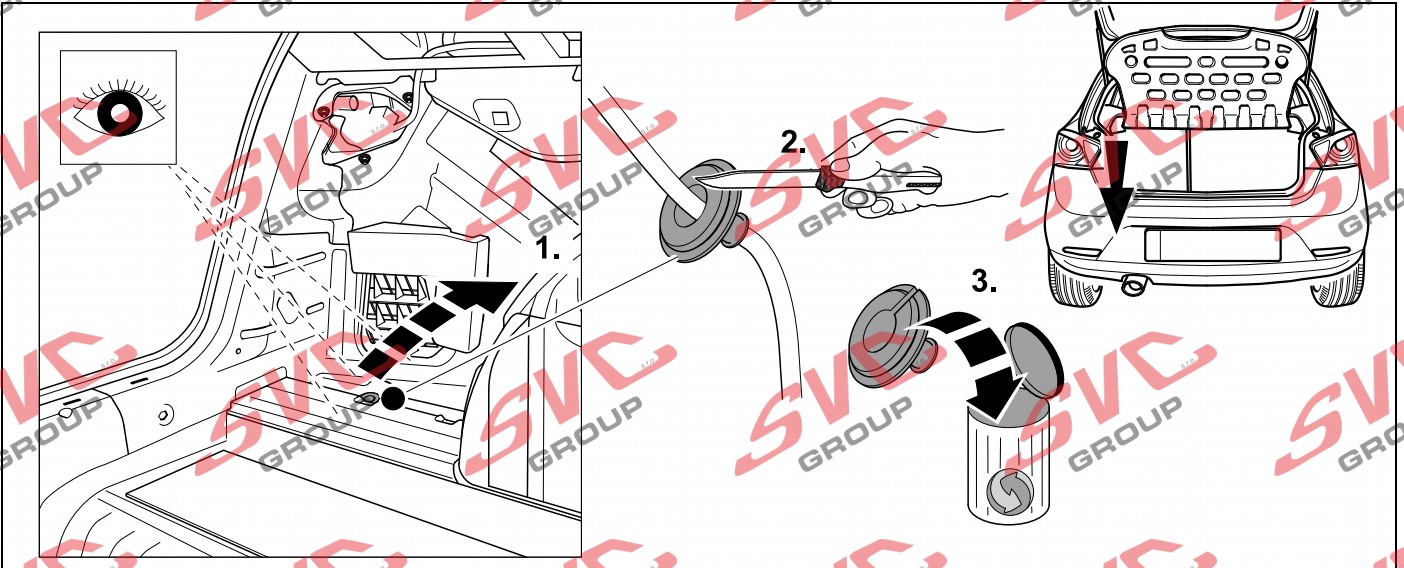



# 11 OPTION 2

Ibiza ST

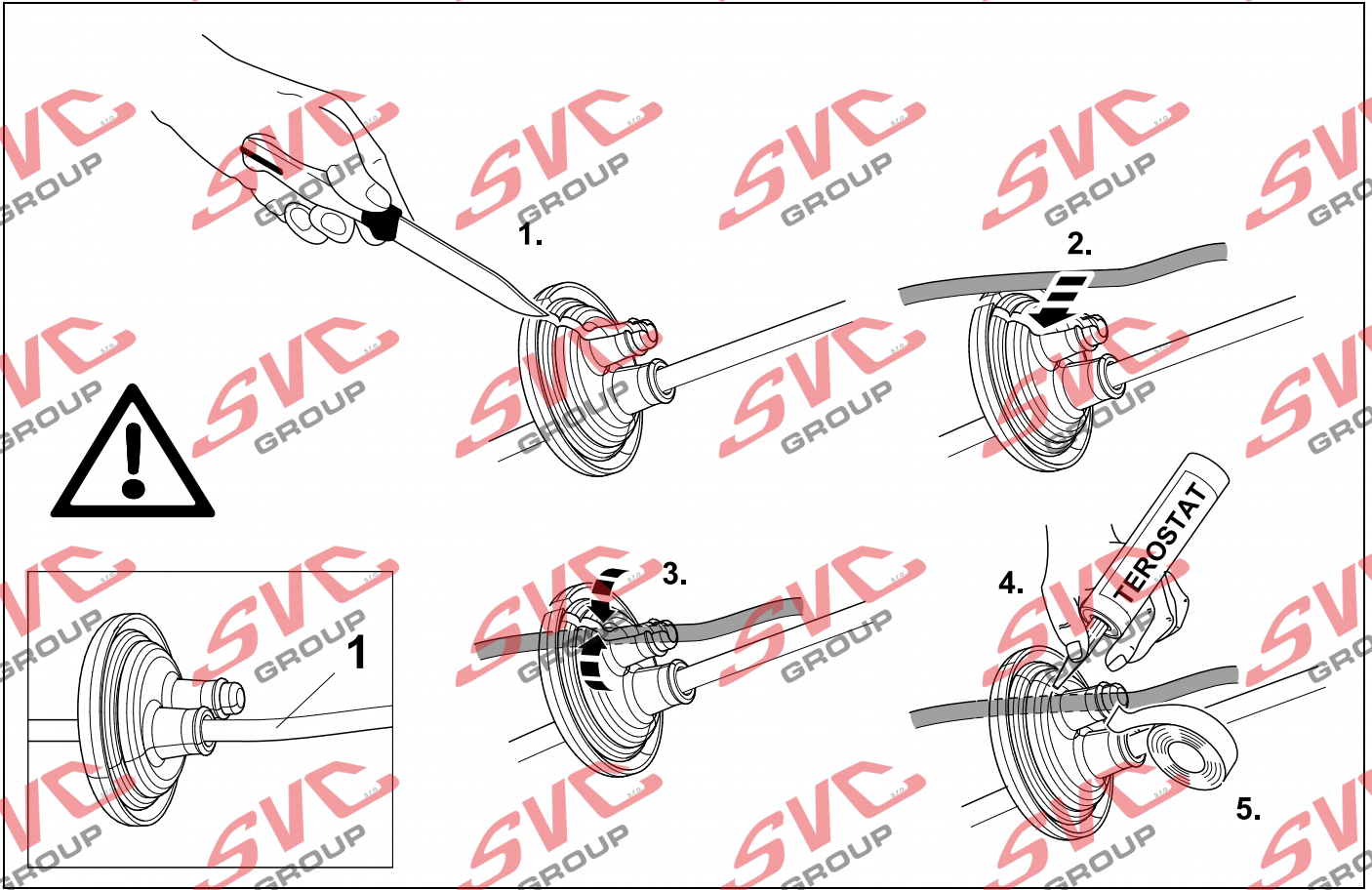

# 12 OPTION 3

Ibiza ST

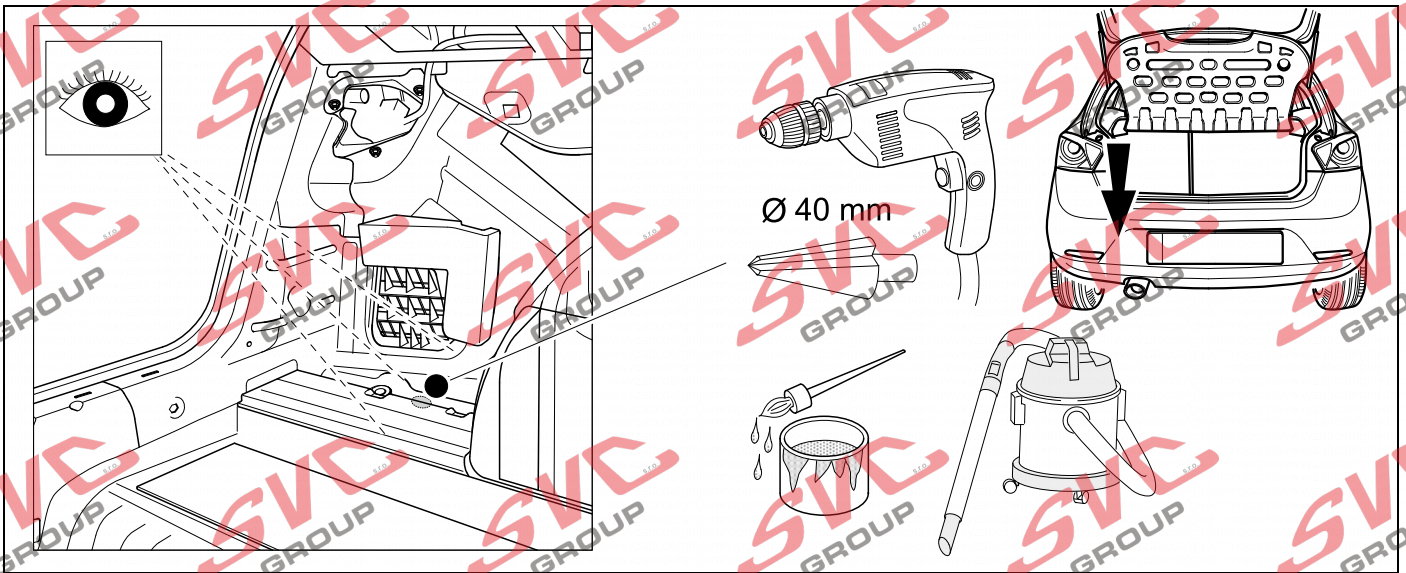

# 13 ROUTING

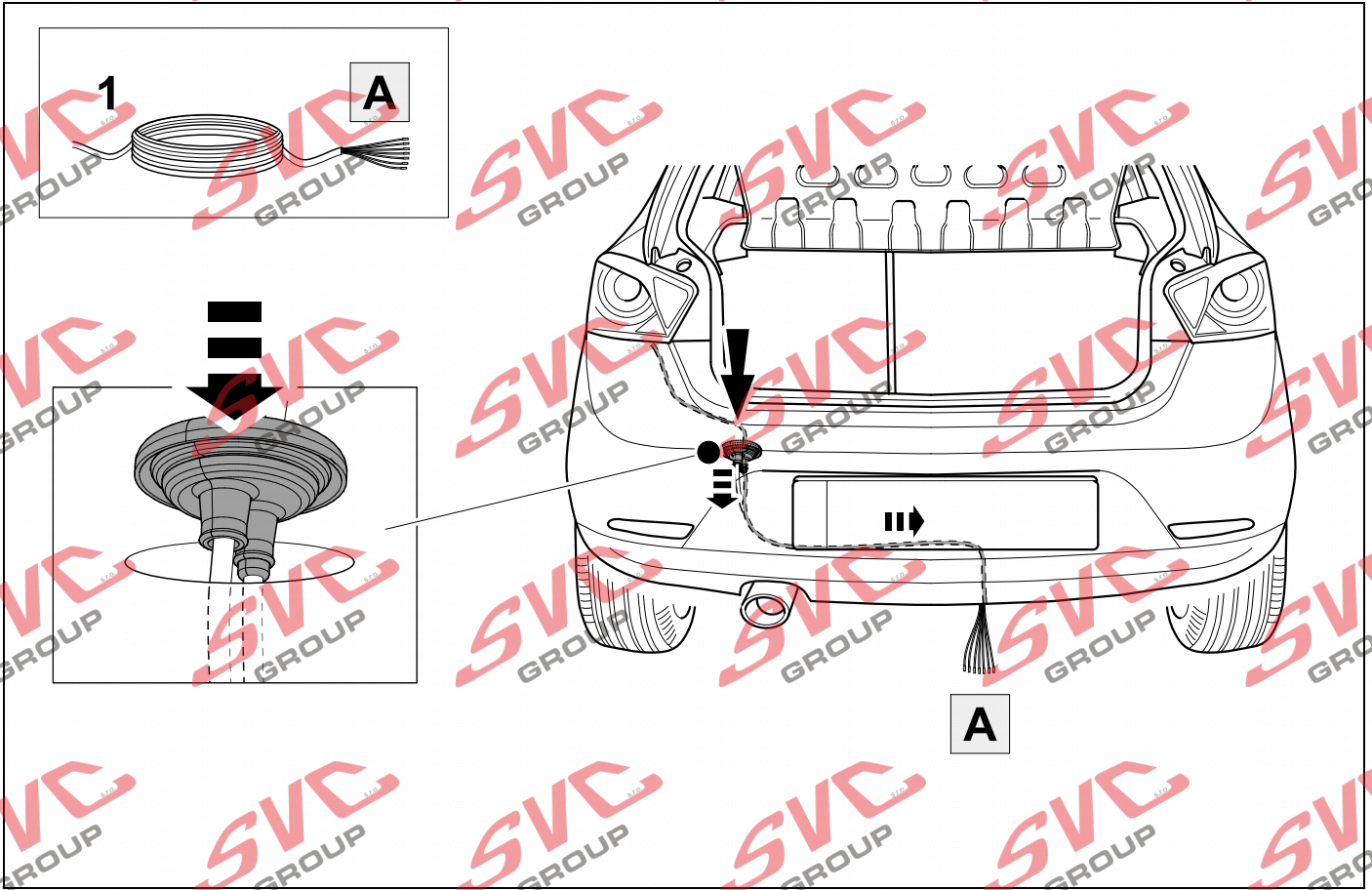

# 14

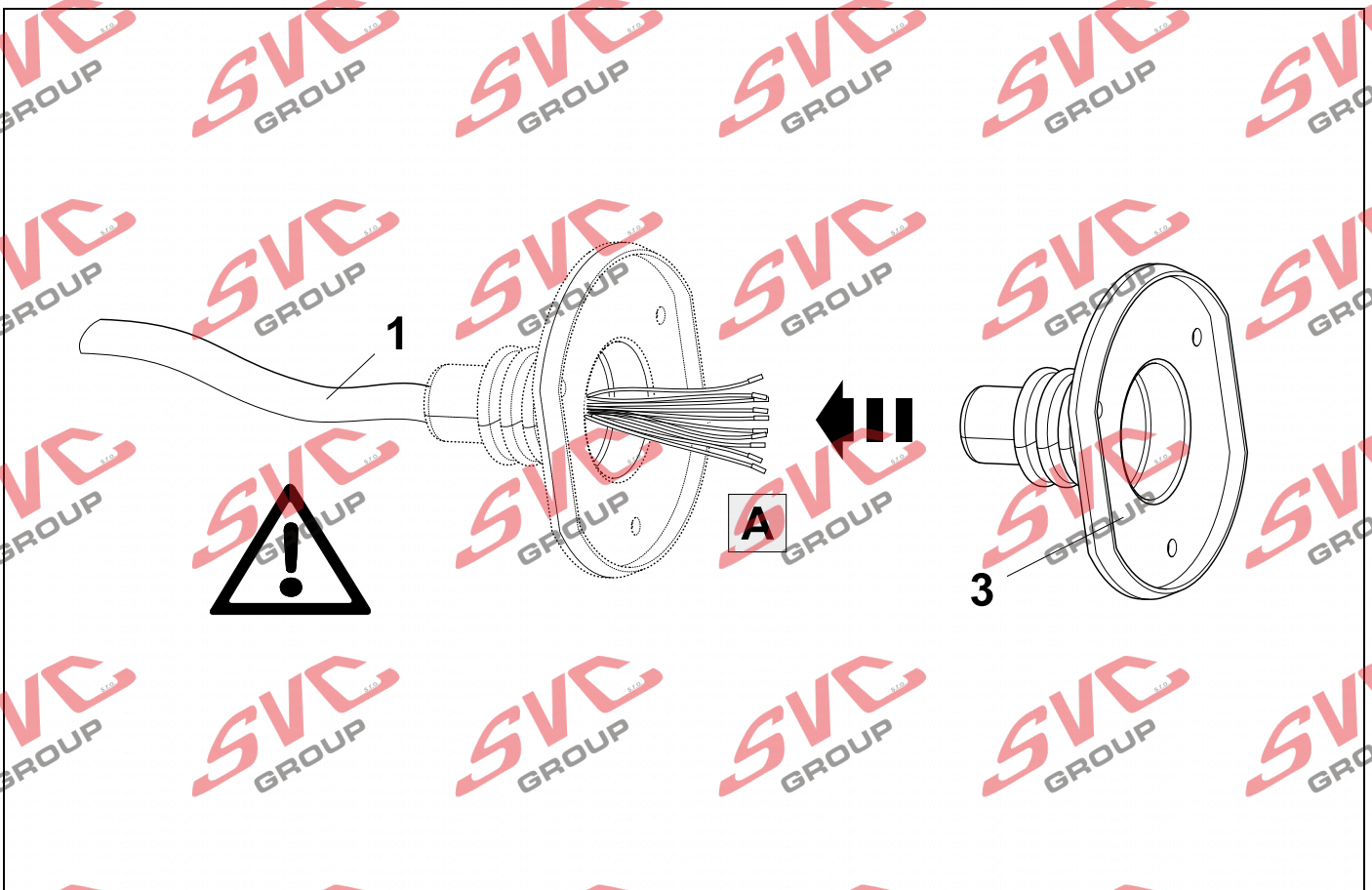



15

16

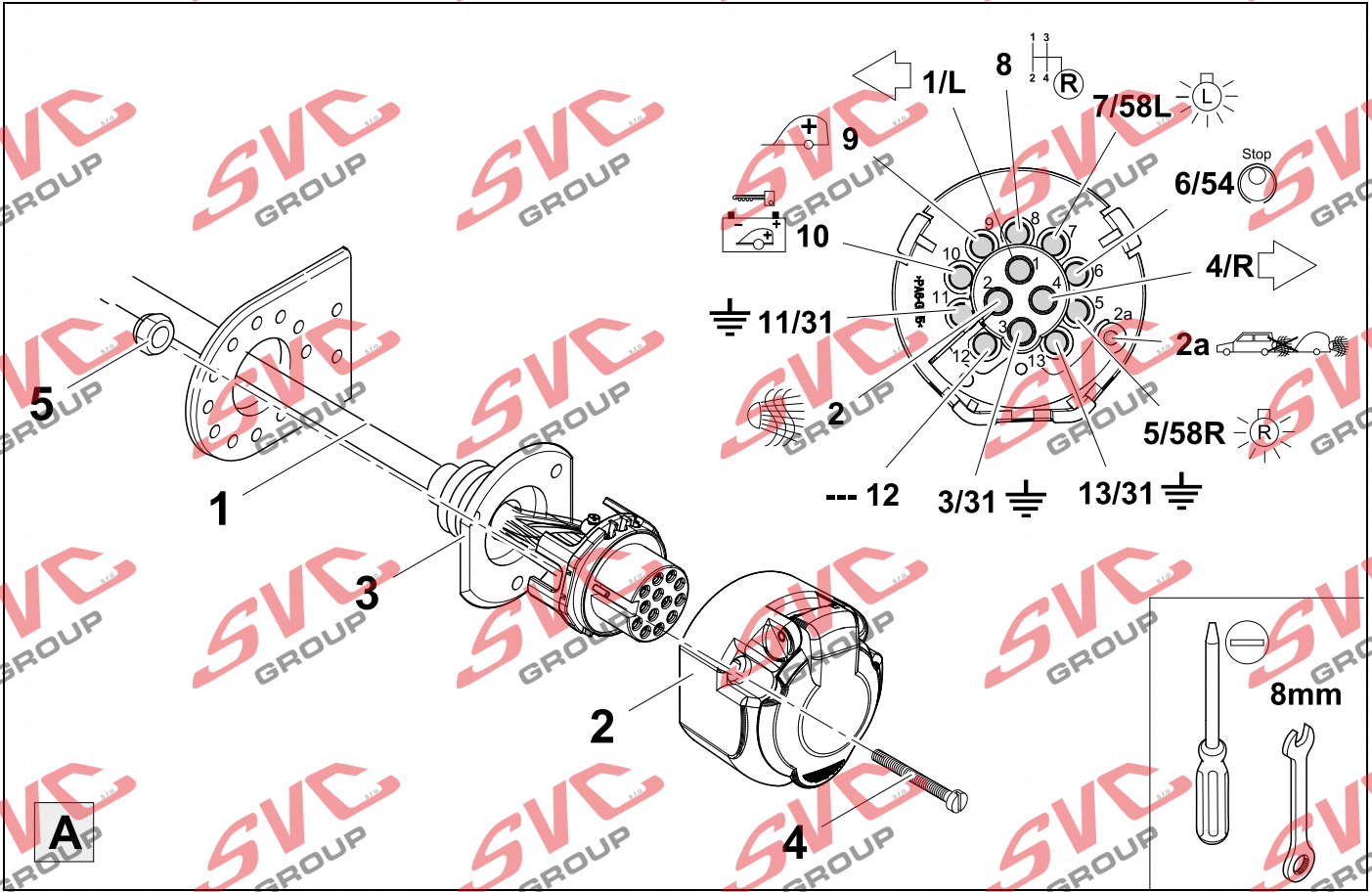

16

17

1	bk/wh		8	bu/rd	
2	gy		9	rd	
3	wh/bn		10	ye	
4	bk/gn		11	bn/gn	
5	gy/rd		12	no	-/-
6	bk/rd		13	bn	
7	gy/bk				
58b/2a	gy/wh				

17	bk	wh	gy	gn	rd	bu	ye	bn	pu	or	no
(D)	schwarz	weiss	grau	grün	rot	blau	gelb	braun	violett	orange	nicht belegt
(GB)	black	white	grey	green	red	blue	yellow	brown	purple	orange	not occupied
(F)	noir	blanc	gris	vert	rouge	bleu	jaune	brun	violet	orange	inutilisé
(NL)	zwart	wit	grijs	groen	rood	blauw	geel	bruin	violet	oranje	niet aangesloten
(DK)	sort	hvid	grå	grøn	rød	blå	gul	brun	violet	orange	ikke anvendt
(N)	svart	hvit	grå	grønn	rød	blå	gul	brun	fiolett	oransje	ikke i bruk
(S)	svart	vit	grå	grön	röd	blå	gul	brun	violett	orange	ej använd
(FIN)	musta	valkoinen	harmaa	vihreä	punainen	sininen	keltainen	ruskea	violetti	oranssi	ei varattu
(I)	nero	bianco	grigio	verde	rosso	blu	giallo	marrone	viola	arancione	libero
(E)	negro	blanco	gris	verde	rojo	azul	amarillo	marrón	violeta	anaranja-do	no ocupado
(P)	preto	branco	cinzento	verde	vermelho	azul	amarelo	castanho	violeta	laranja	não ocupado
(GR)	iaύρνιο	εἰκόνη	Γκρι	δὴνὸόρνιο	ἔῤεἔἔρνιο	ἰδῆἄ	ἔῤῥῥῥῥῥιο	ἔἄῥΥ	Μωβ	πορτοκαλί	ἄἄἰ ἄῤῖἄἄἄ ἔἄῥ ἄἔἔἔἔΥῤῥο
(PL)	czarny	biały	szary	zielony	czerwony	niebiesko	żółty	brazowy	fioletowy	pomarańczowy	wolny
(CZ)	černý	bílý	šedý	zelený	červený	modrý	žlutý	hnědý	fialový	oranžový	neobsazen
(TR)	siyah	beyaz il	gri	yeşmavi	san	kahverengi	mor			portakal rengi	boş
(H)	fekete	fehér	szürke	zöld	piros	kék	sárga	barna	ibolyakék	narancssárga	nem foglalt
(HR)	crno	bijelo	sivo	zeleno	crveno	plavo	žuto	smeđe	ljubi	nije zauzeto	
(BUL)	черен	бял	сив	зелен	червен	син	жълт	кафяв	виолетов	оранжев	свободно
(RO)	negru	alb	gri	verde	galben	maro	violet	portocaliu	liber		
(RU)	черный	белый	серый	зеленый	красный	голубой	жёлтый	коричневый	пурпурный	оранжевый	свободно
(LT)	juoda	balta	pilka	žalia	geltona	ruda	oranžinė	laisva			
(LV)	melna	balta	pelna	sarkana	zaļa	dzeltena	brūna	purpur-sarkana	oranža	brīva	
(EST)	must	valge	hall	roheline	punane	sinine	kollane	pruun	purpur-punane	oraanž	vaba
(SLO)	črna	bela	siva	zelená	rdeča	modra	rumena	oranžna			ni zasedeno
(SK)	čierny	biely	šedý	zelený	červený	modrý	žltý	hnědý	fialový	pomarančový	neobsadený



18

Ibiza 3-door/Ibiza 5-door

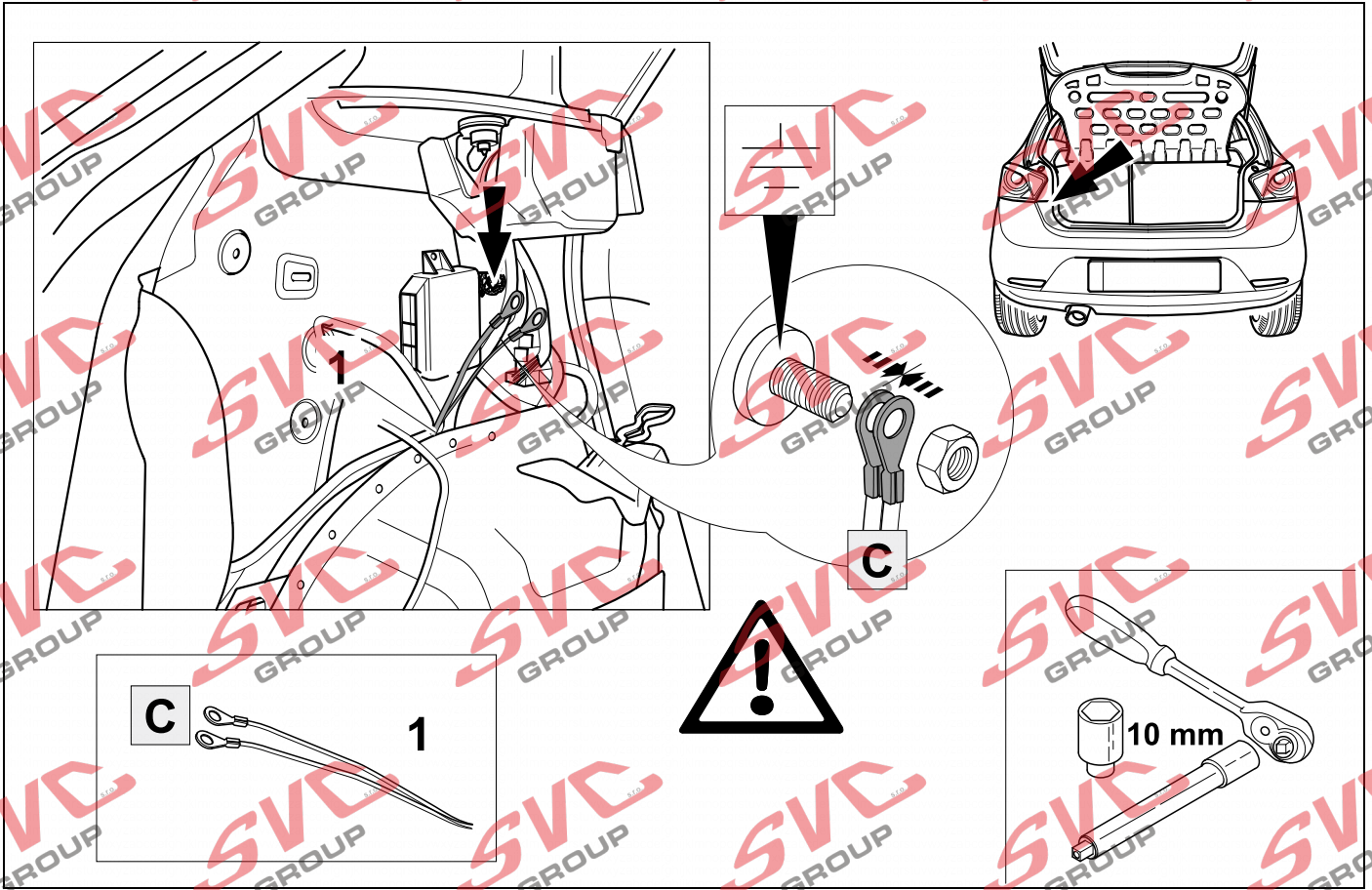

19

Ibiza ST

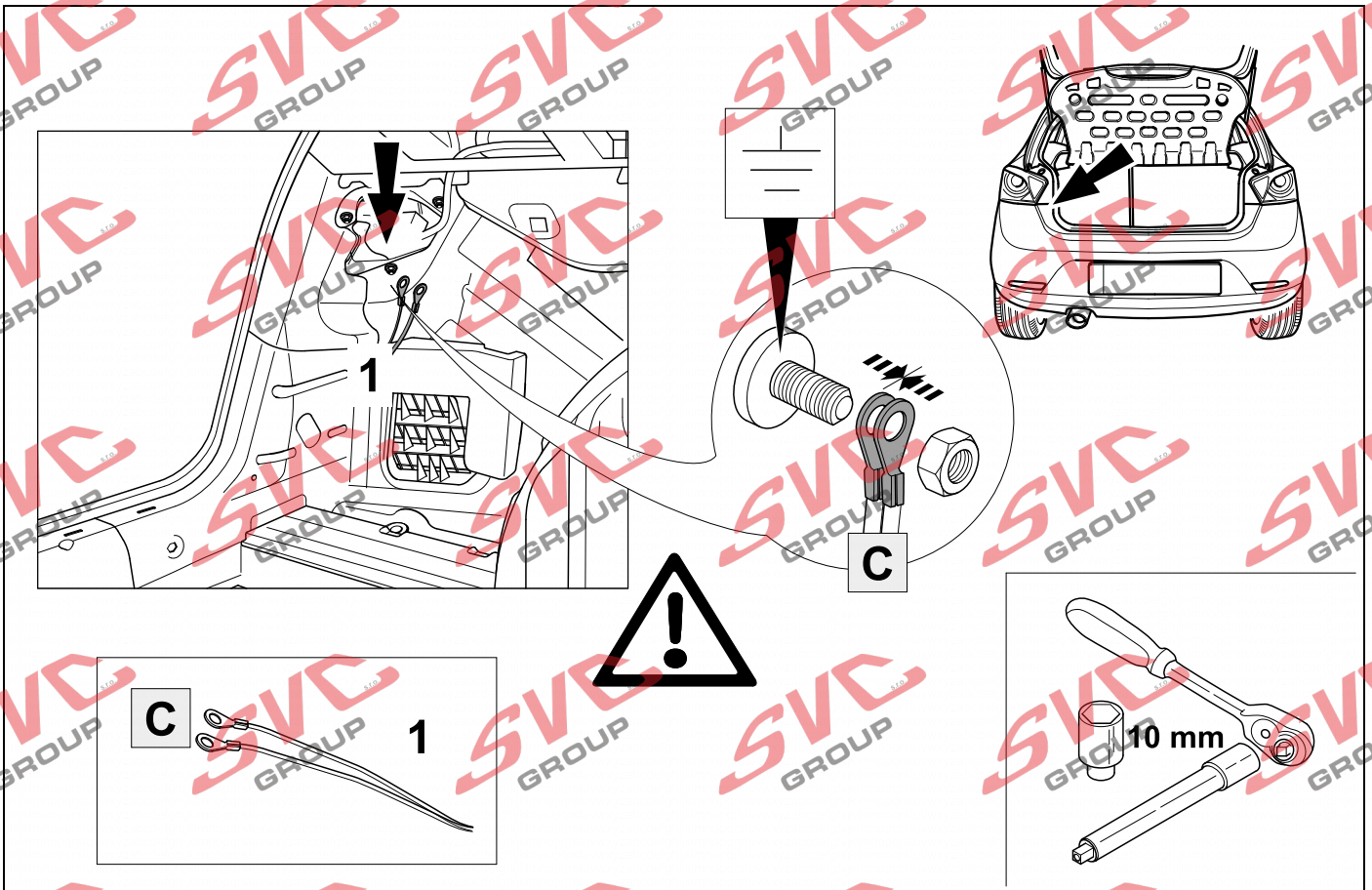

20

Ibiza 3-door/Ibiza 5-door

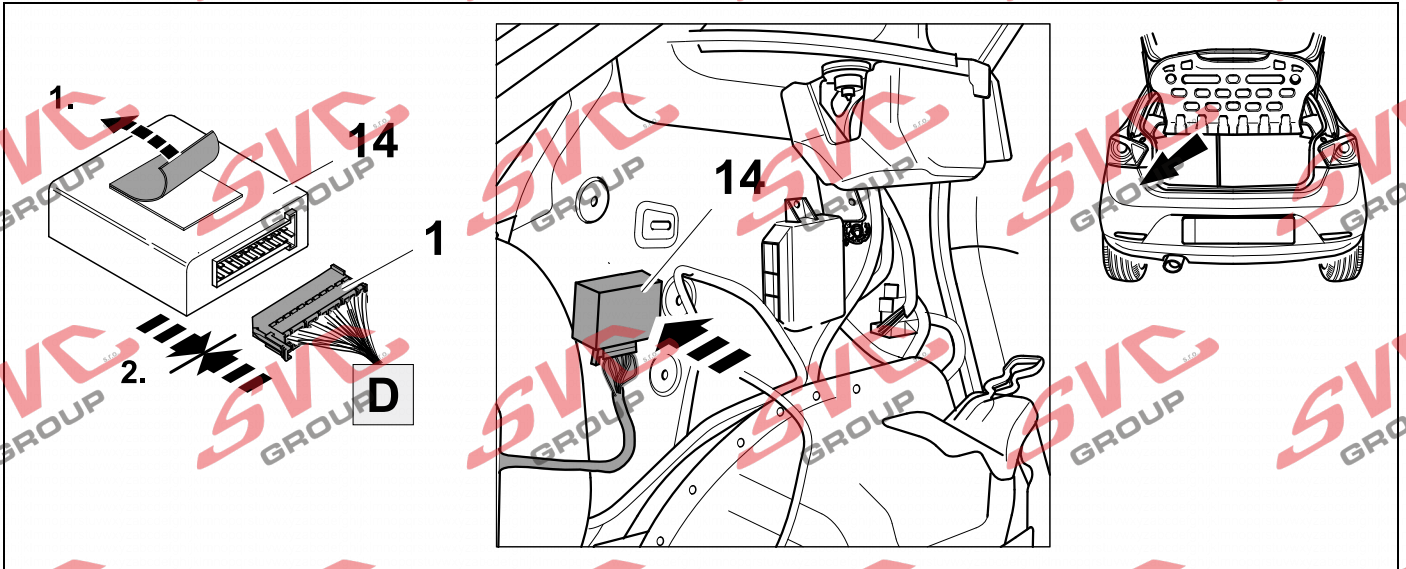

21

Ibiza ST

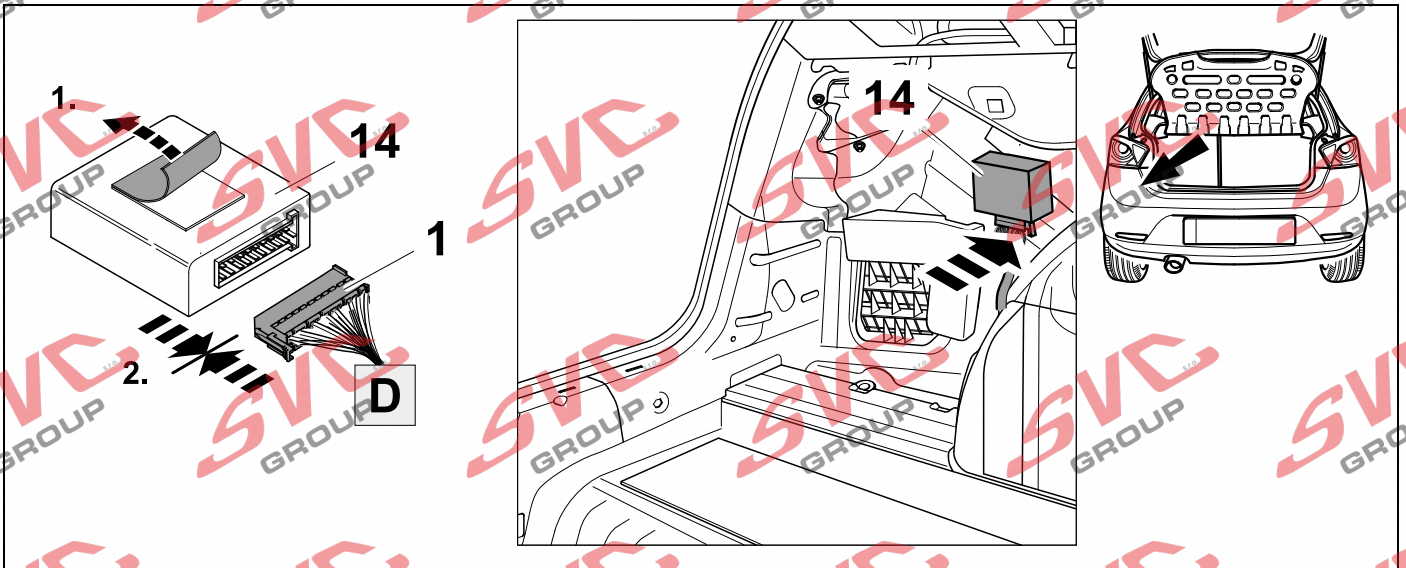



22



17

Ibiza 3-door/Ibiza 5-door

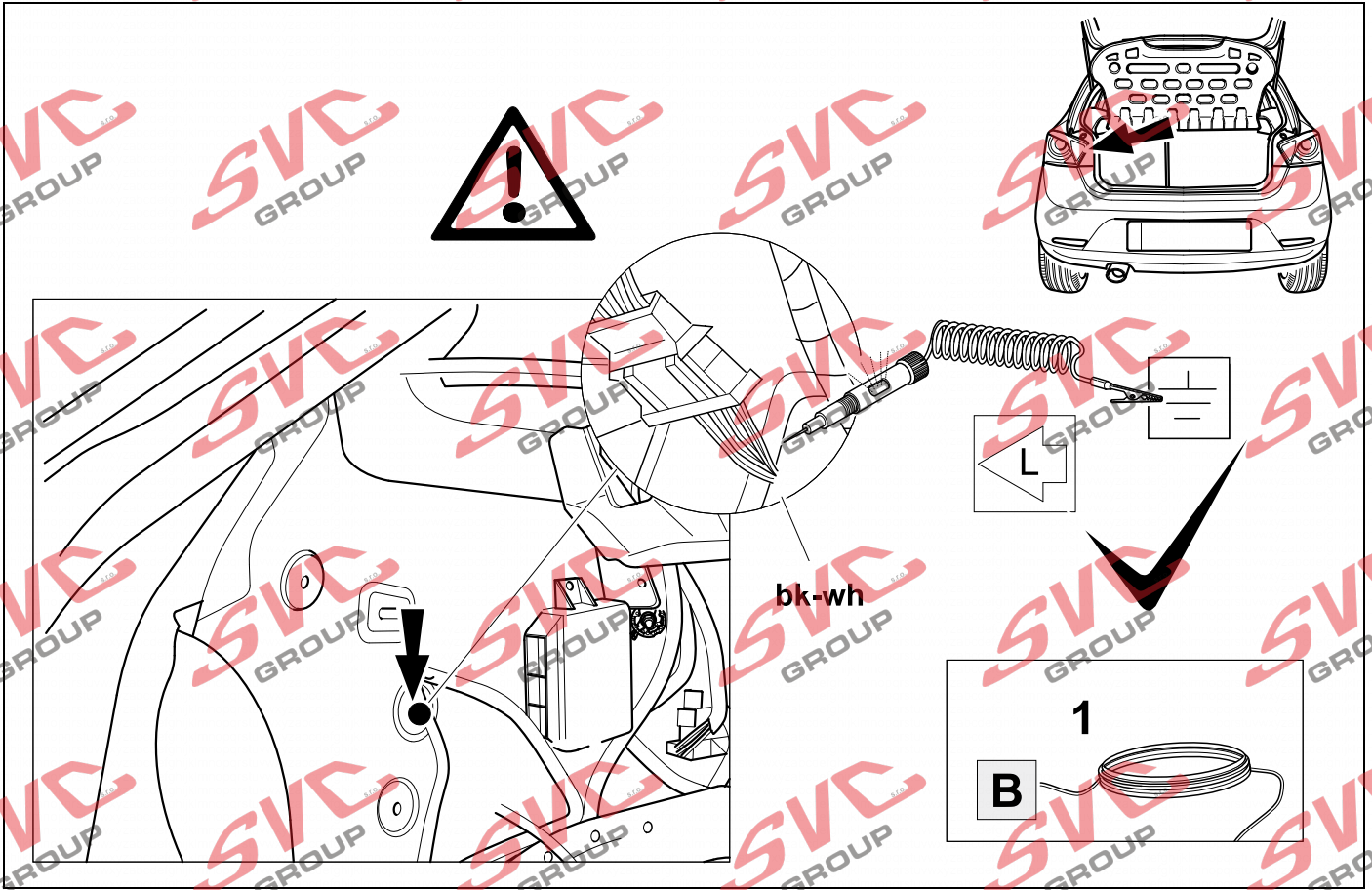

23



17

Ibiza 3-door/Ibiza 5-door

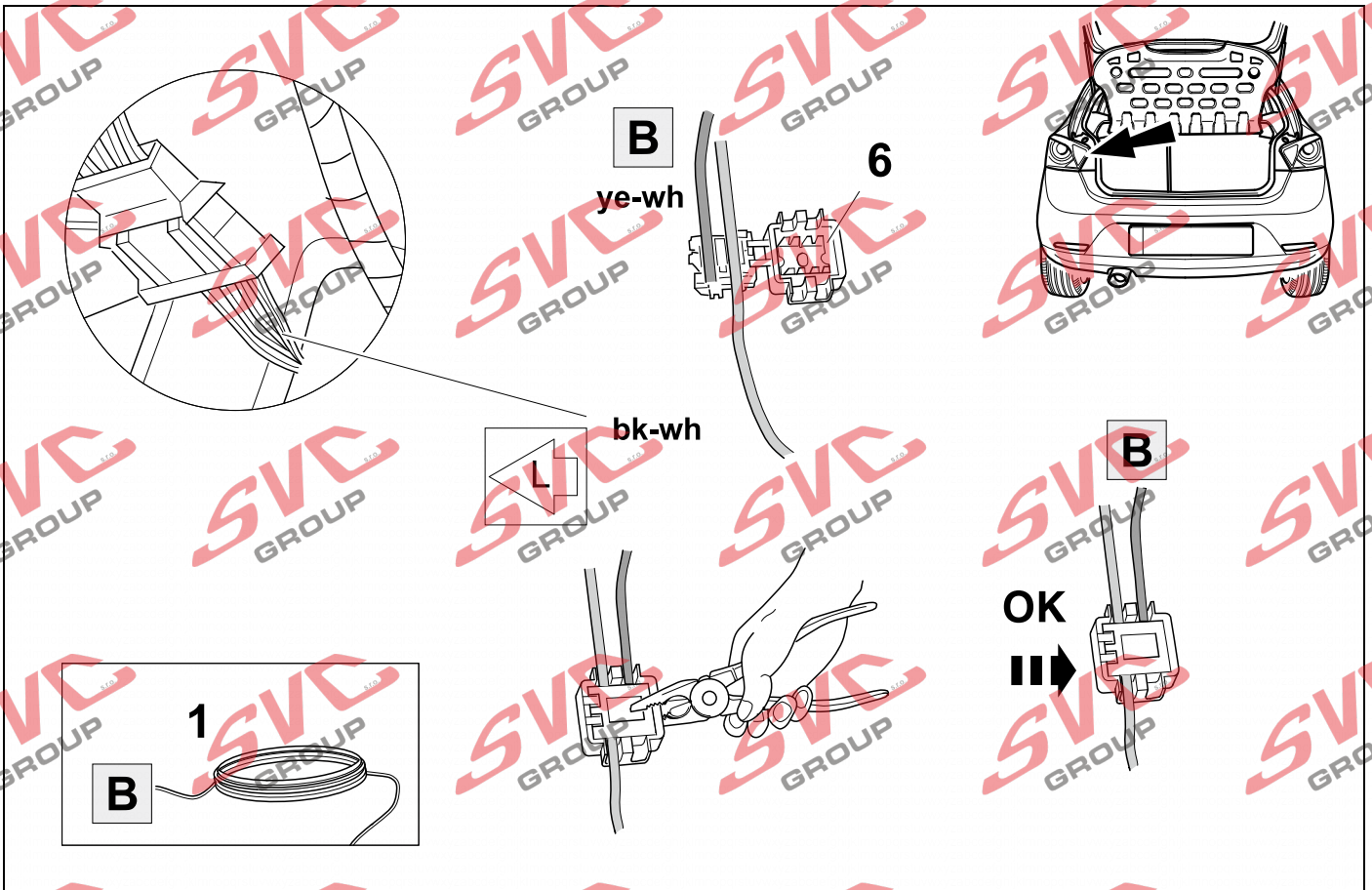

24



17

Ibiza ST

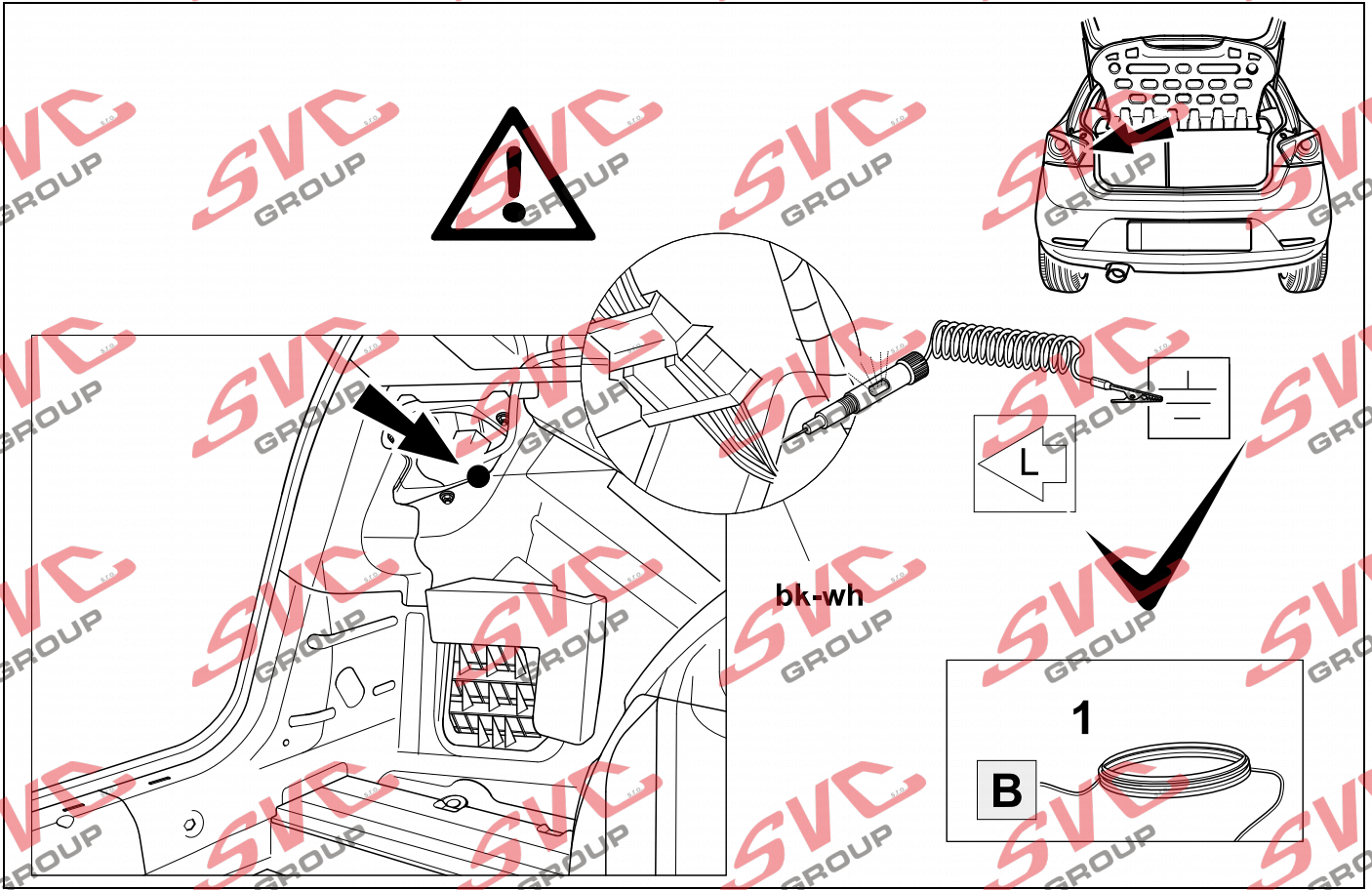

25



17

Ibiza ST

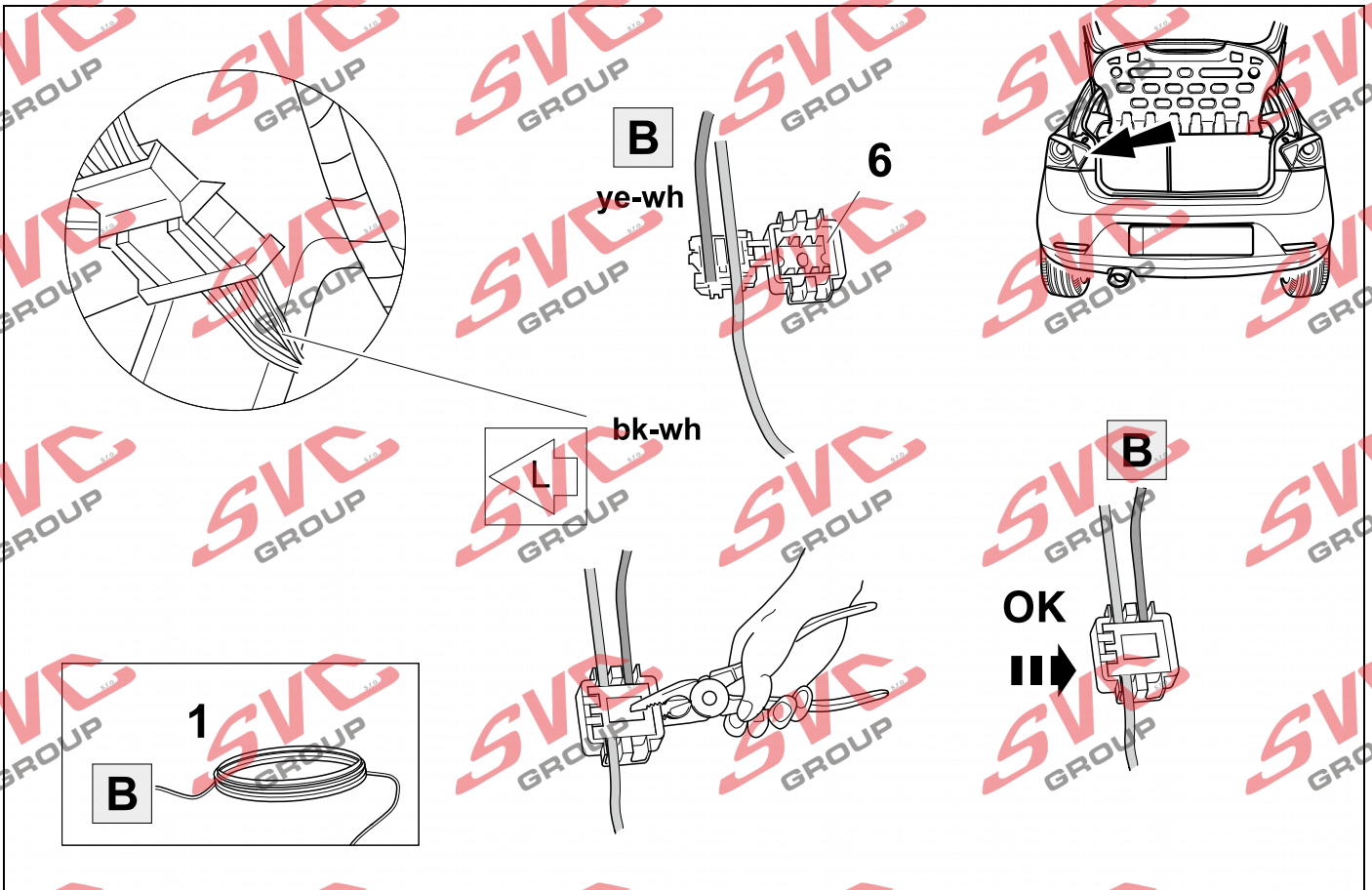



26

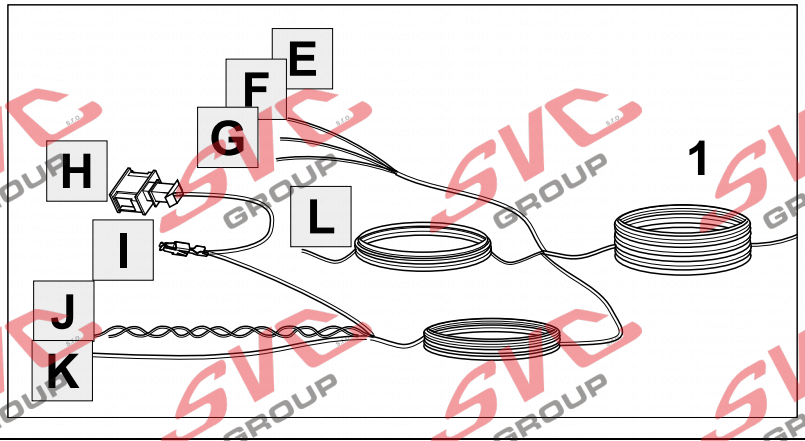
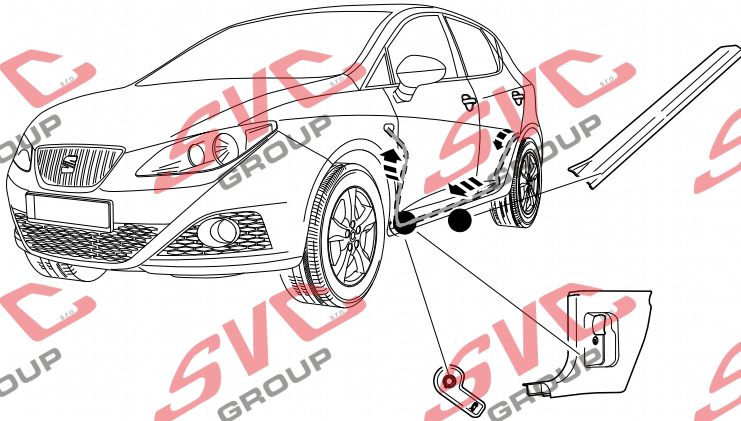

27



17

### CAN - Wire

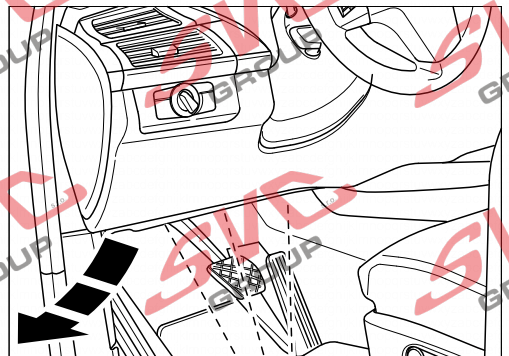

bk

wh

A

B

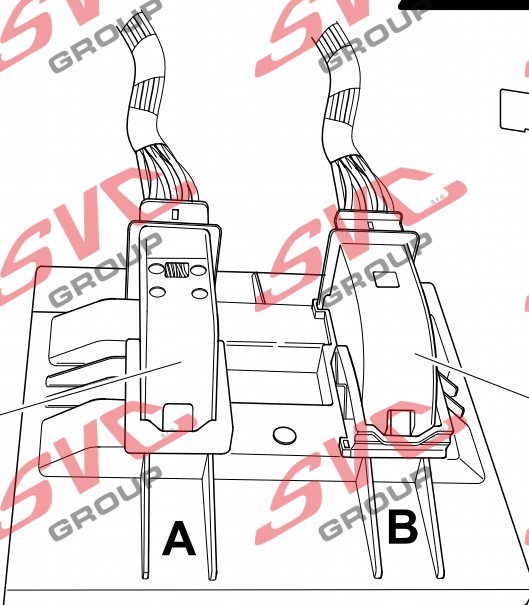

28

### CAN - Wire

17

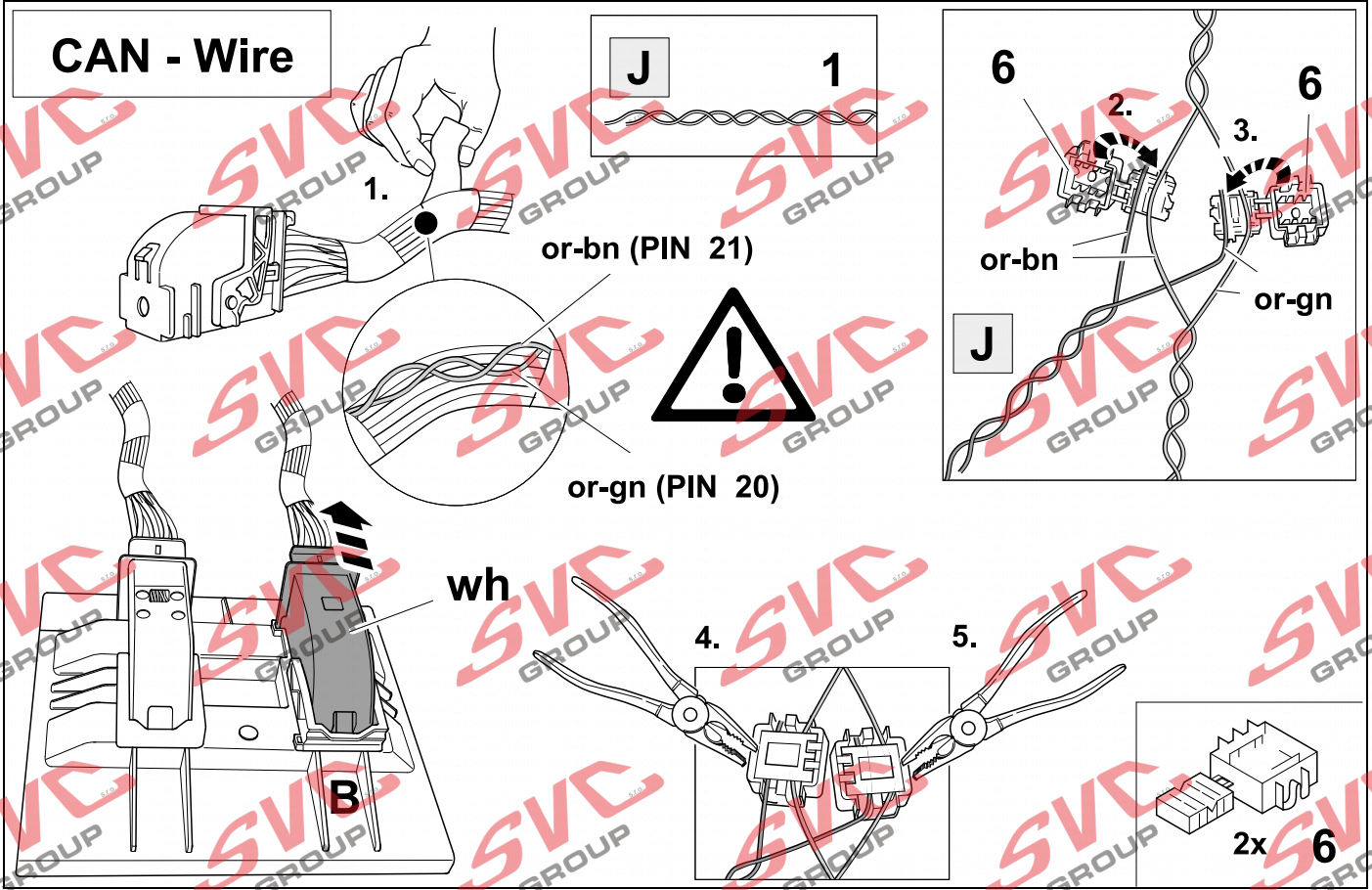

29

17

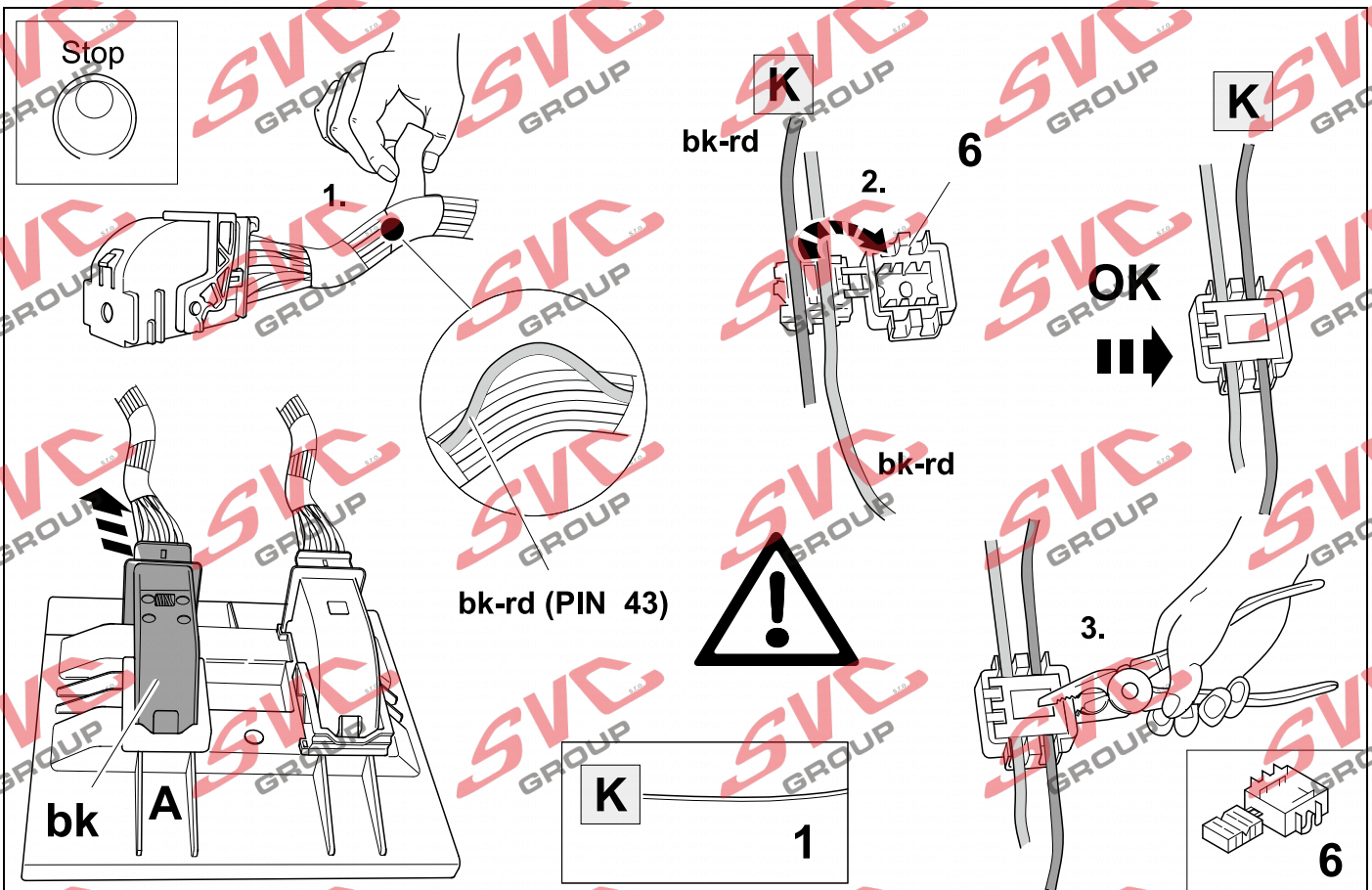



30

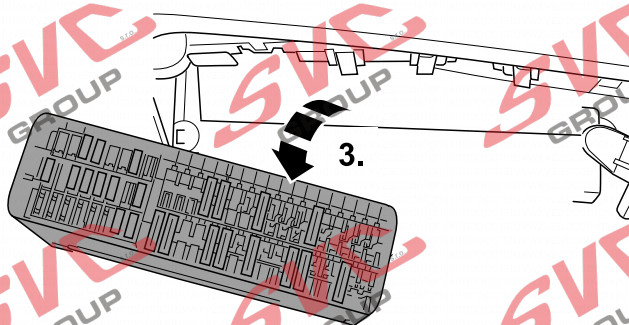
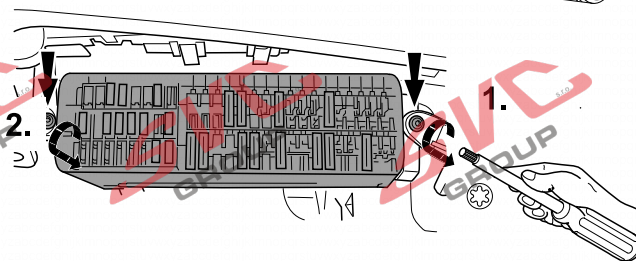
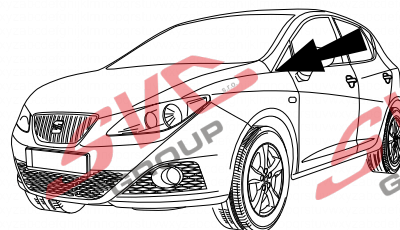
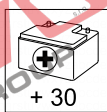
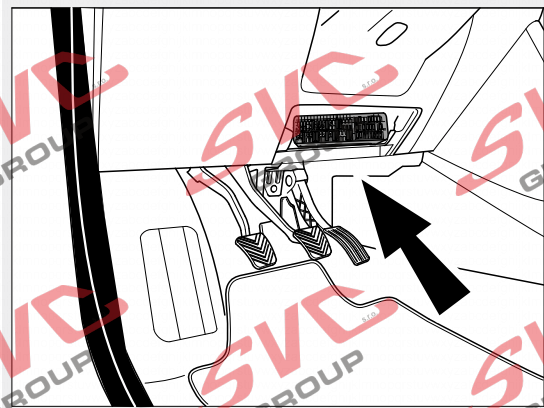

31

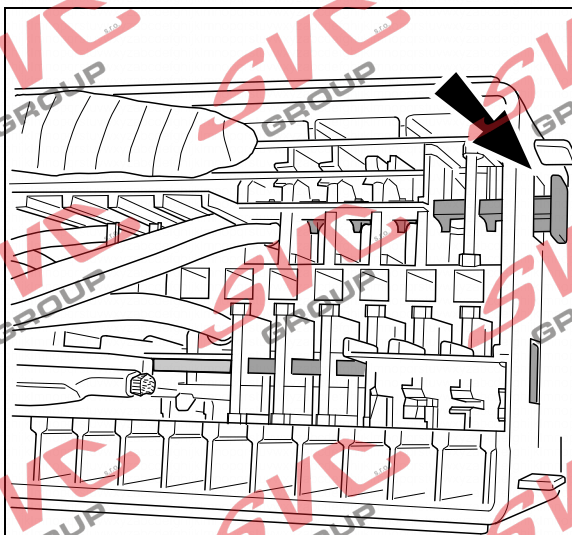

2.

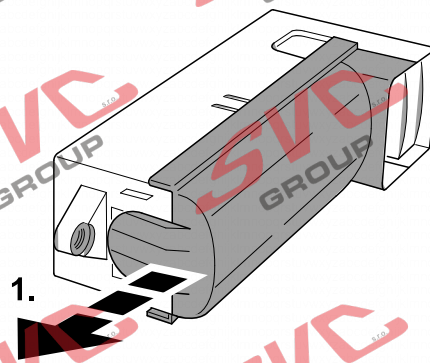

1.

32

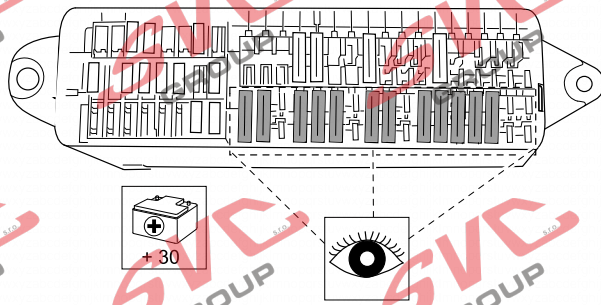

OPTION A

33 + 34

38 - 60

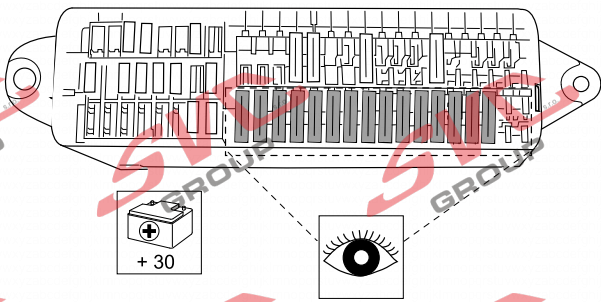

OPTION B

35 - 60

### 33 OPTION A

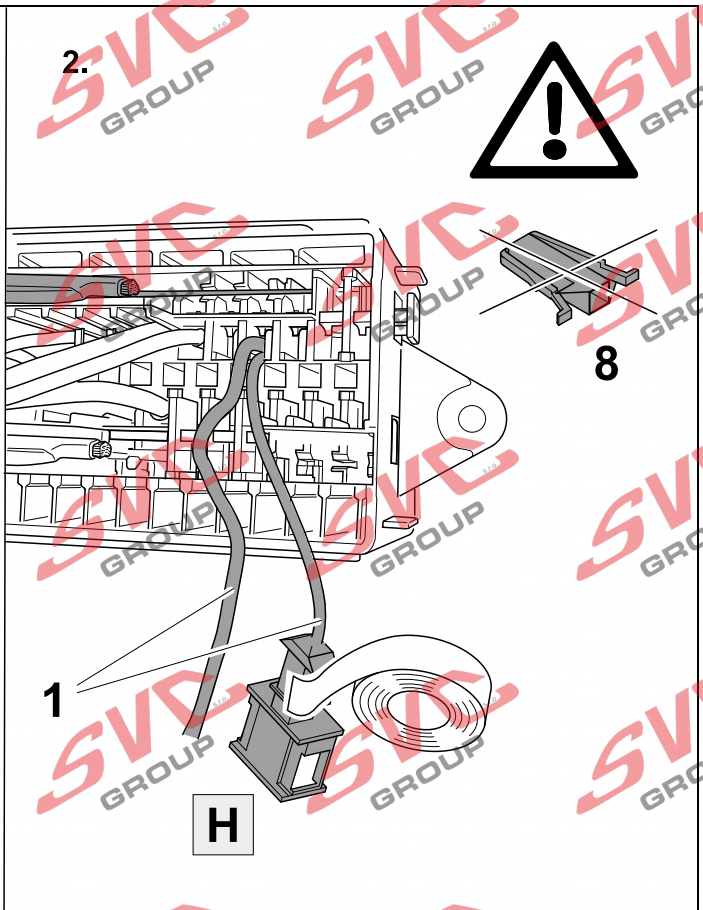
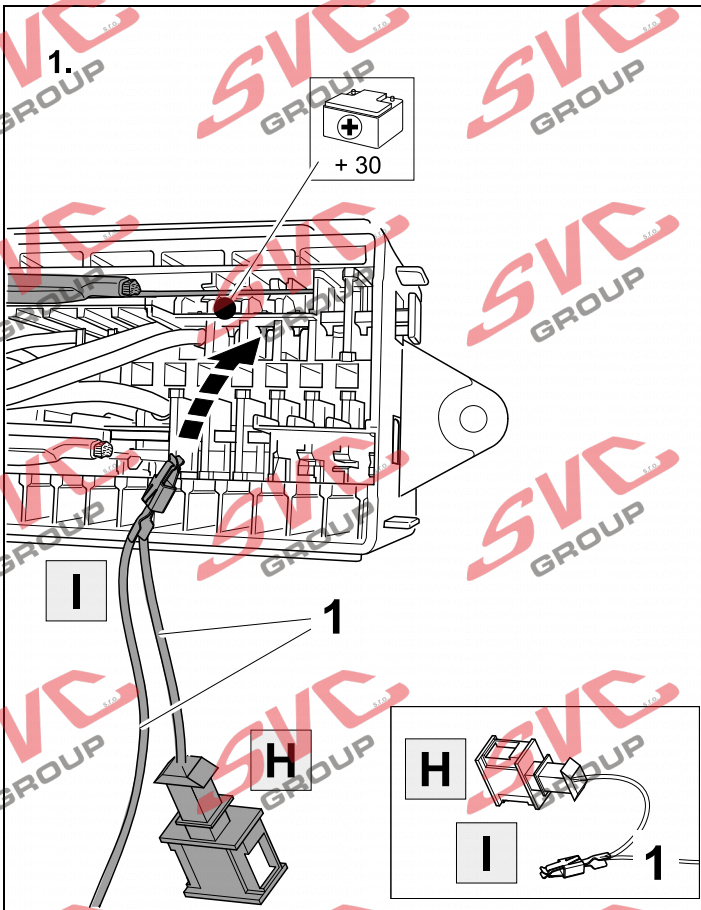



### 34 OPTION A



58

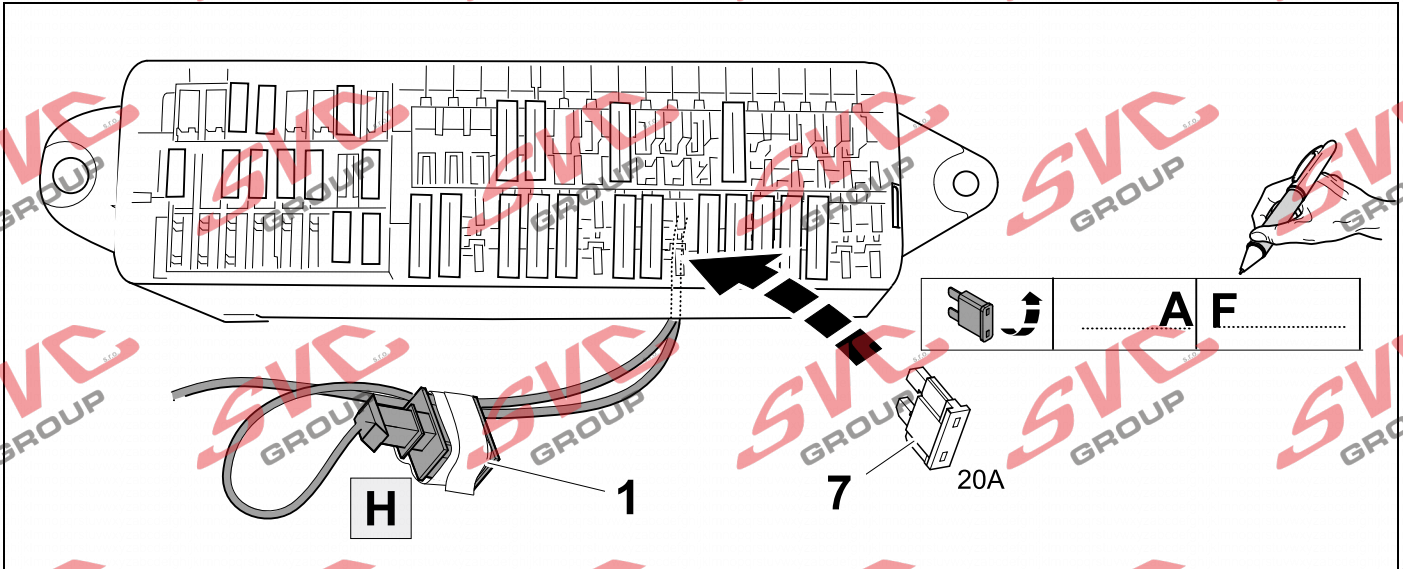

### 35 OPTION B

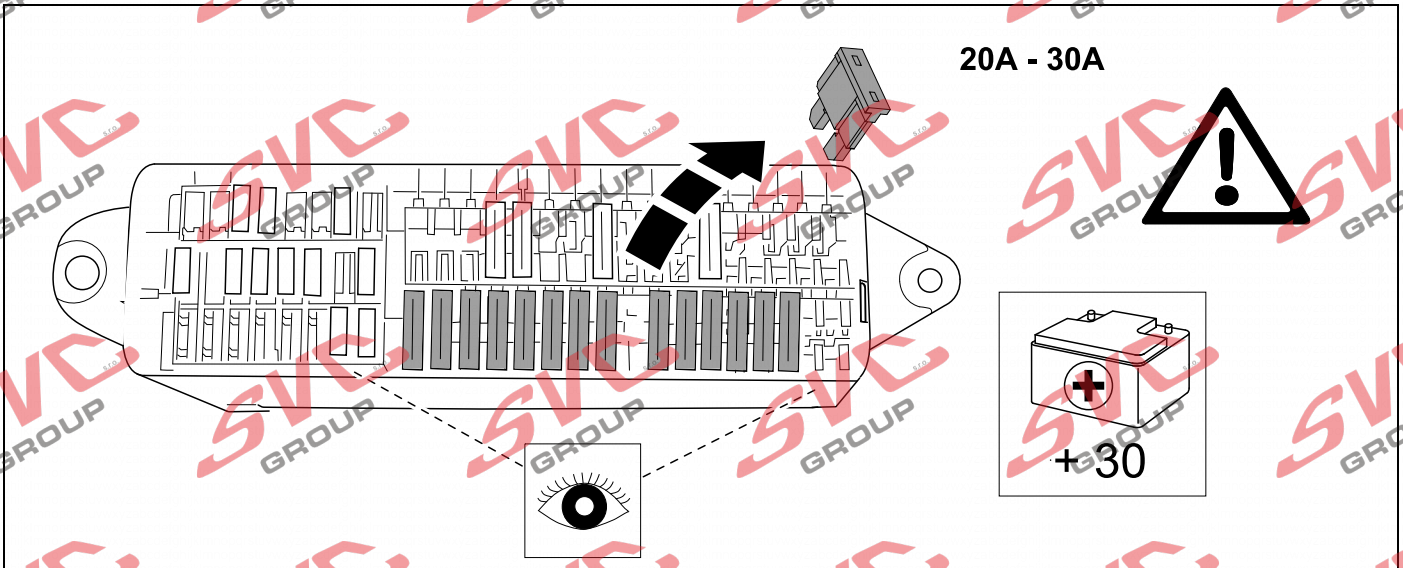

# 36 OPTION B

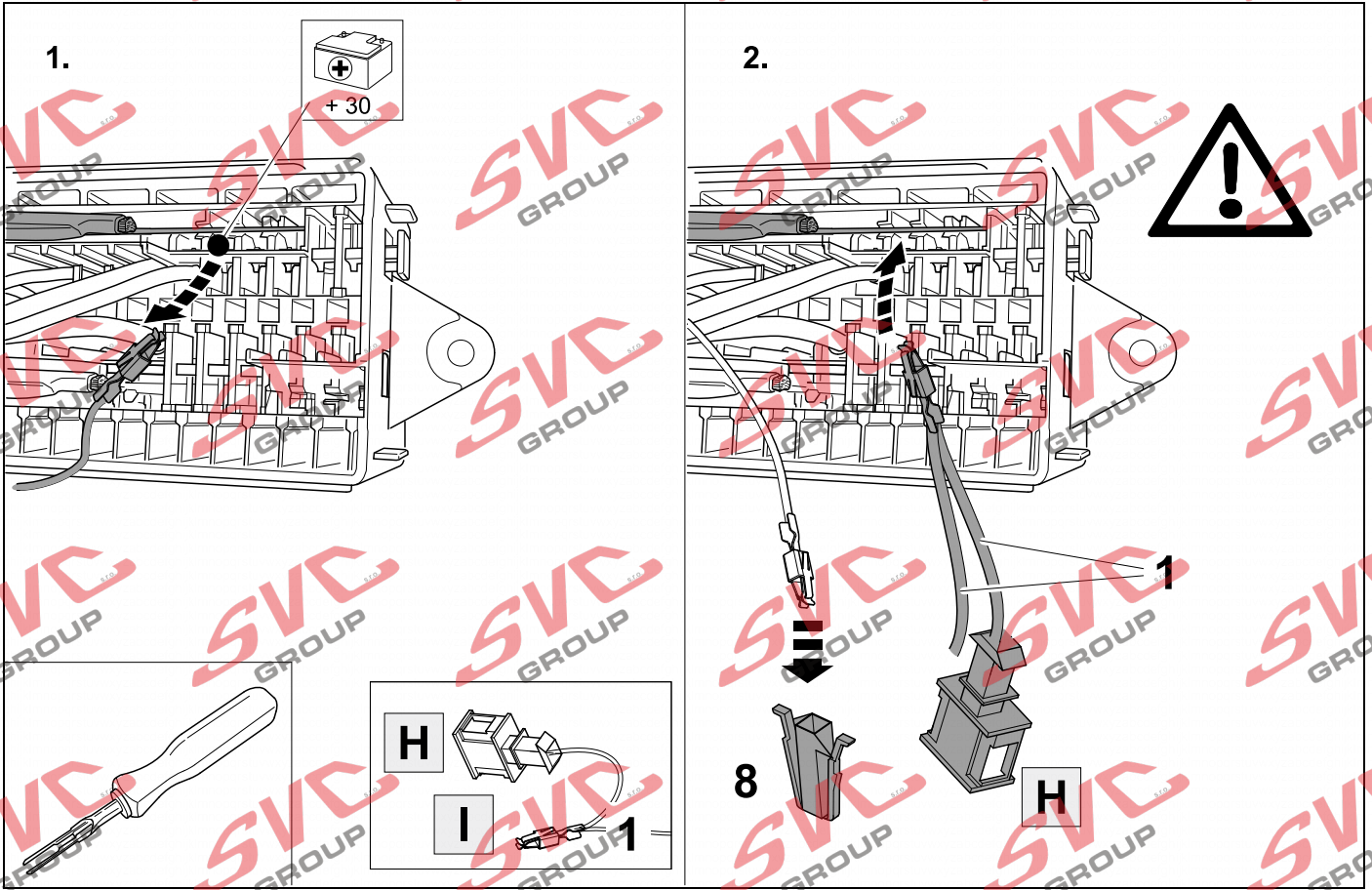

# 37 OPTION B



58

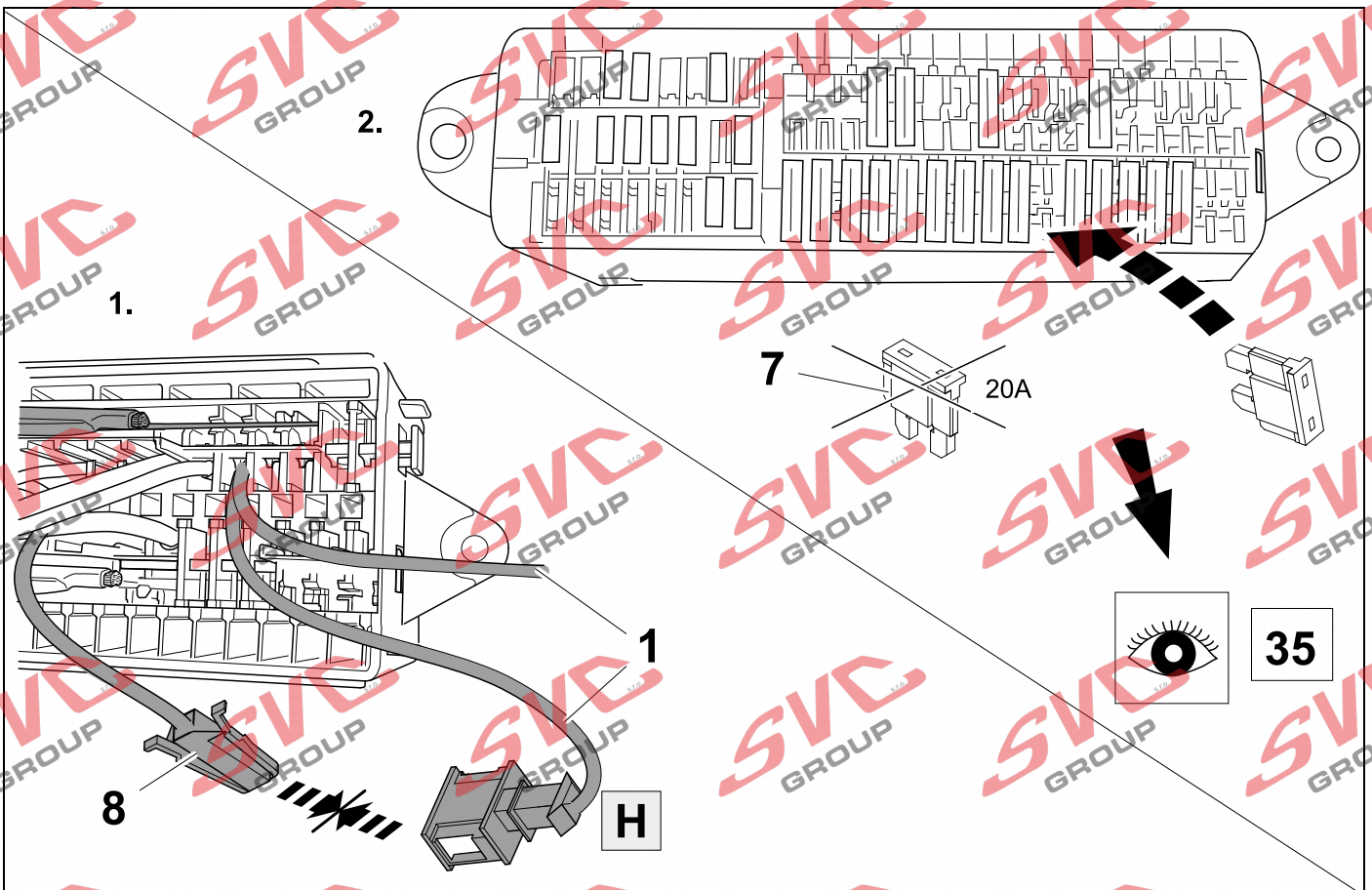



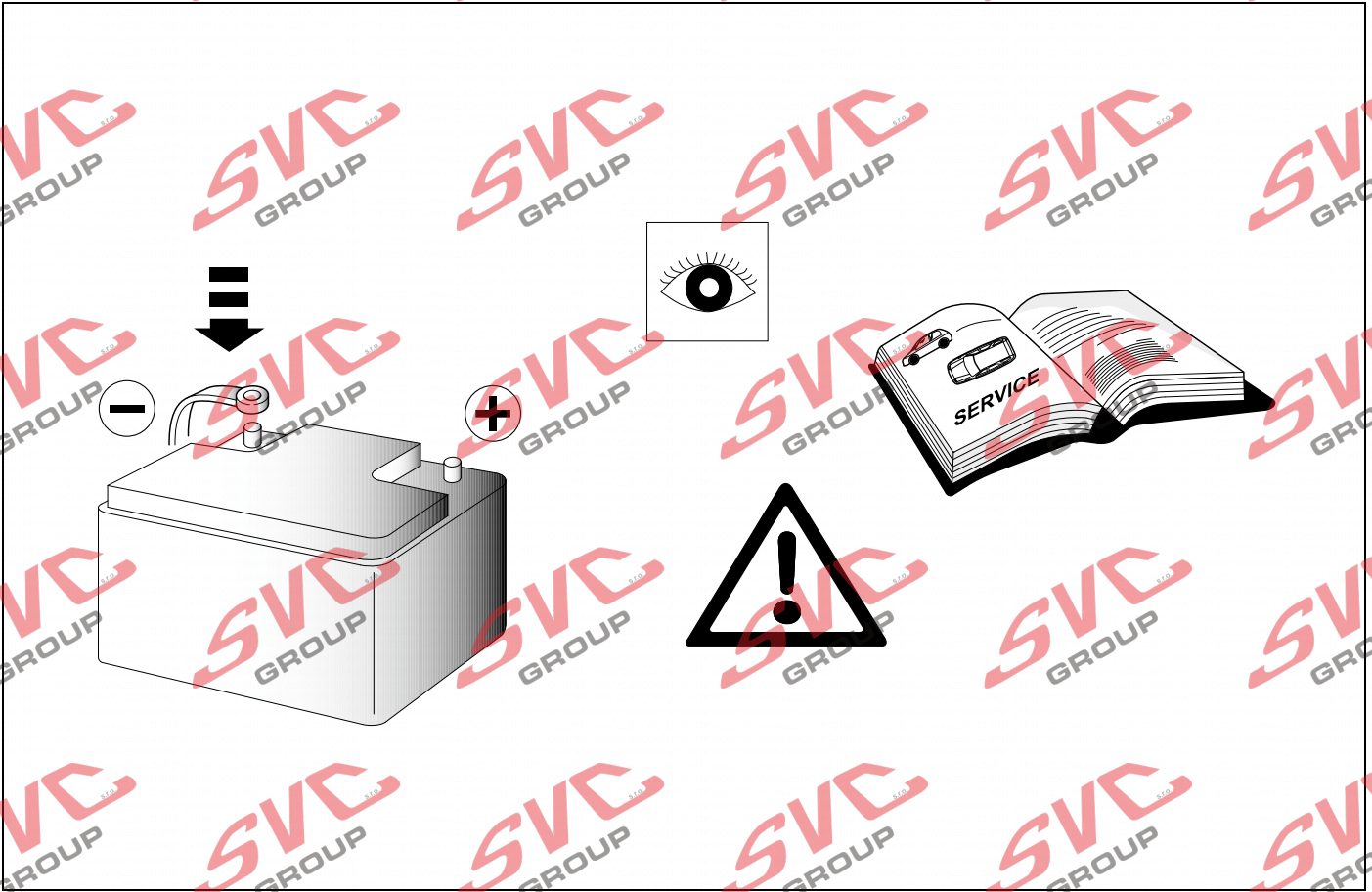

# 39 CODING

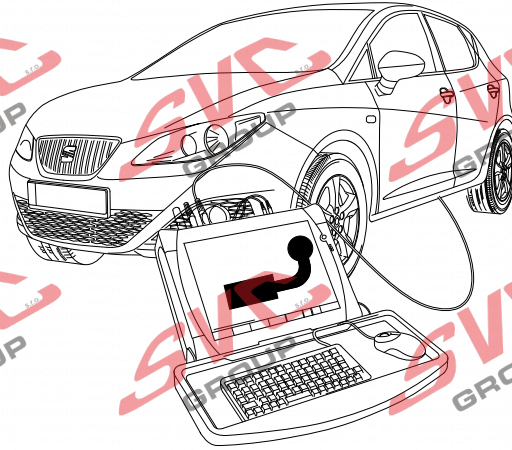

## Codierung bitte wie folgt durchführen D

- Fahrzeug-Eigendiagnose
- Eigendiagnose
- 19 - Diagnoseinterface für Datenbus
- 008 - Codierung (Dienst 22)
- 008.02 Verbauliste codieren
- 69 - Anhängerfunktion ( auf codiert schalten!)
- mit OK bestätigen!

### Fahrzeuge mit Einparkhilfe II

- Fahrzeug-Eigendiagnose
- 10 - Einparkhilfe II
- 009 Codierung
- Master
- 009.02 Klartextcodierung
- Anhängersystem auswählen
- mit OK bestätigen!

### Wichtige Hinweise

Fahrzeuge mit Start-Stopp-Automatik:

Bei Anhängerbetrieb ist die Start-Stopp-Automatik deaktiviert!

## Please effect coding as follows GB

- Vehicle self-diagnosis
- self-diagnosis
- 19 - diagnosis interface for data bus
- 008 - Coding (service 22)
- 008.02 assembly list coding
- 69 - trailer function ( switch to coded!)
- confirm with OK !

### Vehicles with park assist systems II

- Vehicle self-diagnosis
- 10 - park assist system II
- 009 Coding
- Master
- 009.02 plain text coding
- select trailer system
- confirm with OK !

### Important notices

Vehicles with start-stop system:

The start-stop system is deactivated in trailer mode!

## Veillez effectuer le codage comme il suit F

- autodiagnostic du véhicule
- autodiagnostic
- 19 - interface de diagnostic pour bus de données
- 008 - codage (service22)
- 008.02 - codage liste d'assemblage
- 69 - mode remorque ( commuter à encodé!)
- Confirmer en appuyant sur OK

### Véhicules avec système d'aide au parking II

- autodiagnostic du véhicule
- 10 - système d'aide au parking II
- 009 Codage
- Master
- 009.02 Codage en langage clair
- Sélectionner le système remorque
- Confirmer en appuyant sur OK

### Remarques importantes

Véhicules avec système automatique de démarrage et d'arrêt :

Le système automatique de démarrage et d'arrêt est désactivé pendant le remorquage.

## Si prega di eseguire la codifica come segue E

- Autodiagnosi del veicolo
- Autodiagnosi
- 19 - Interfaccia di diagnosi per il data bus
- 008 - codifica (servizio 22)
- 008.02 - codifica Lista
- 69 - Funzione rimorchio (commutare su codificato!)

### Veicoli con sensori di parcheggio II

- Autodiagnosi del veicolo
- 10 - sensori di parcheggio II
- 009 Codifica
- Padrone
- 009.02 codifica testo
- selezionare sistema rimorchio
- Confermare con OK!

### Avvertenze importanti

Veicoli con start-stop automatico:

Nel funzionamento con rimorchio lo start-stop automatico è disattivato!

## Codificar del siguiente modo E

- Autodiagnóstico del vehículo
- Autodiagnóstico
- 19 - Interfaz de diagnóstico para bus de datos
- 008 - Codificación (servicio 22)
- 008.02 - Codificación Lista
- 69 - Función del remolque (codificación)

Vehículos con sistema de ayuda para el aparcamiento II

- Autodiagnóstico vehículo
- 10 - ayuda al aparcamiento II
- 009 Codificación
- Maestro
- 009.02 Codificación de texto
- Remolque seleccione
- Confirmar con OK!

### Advertencias importantes

Vehículos con sistema automático de arranque y parada:

En el servicio con remolque, el sistema automático de arranque y parada está desactivado!

## Gelieve codering als volgt door te voeren NL

- Eigen diagnose voertuig
- Eigen diagnose
- 19 - diagnose-interface für gegenvensinvoerbus
- 008 - Codering (dienst 22)
- 008.02 - Codering inbouwlijst
- 69 - aanhangwagenfunctie (op "Gecodeerd" schakelen!)

### Voertuigen met parkeerhulp II

- Eigen diagnose voertuig
- 10 - parkeerhulp II
- 009 Codering
- Meester
- 009.02 Codering tekst
- Selecteer aanhangwagen
- met OK bevestigen!

### Belangrijke aanwijzingen

Voertuigen met automatische start/stop:

In de modus "Aanhangwagen" is de automatische start/stop gedeactiveerd!



40

**VERY IMPORTANT !**

**Check fog lamp situation after coding!**

**OPTION 1**

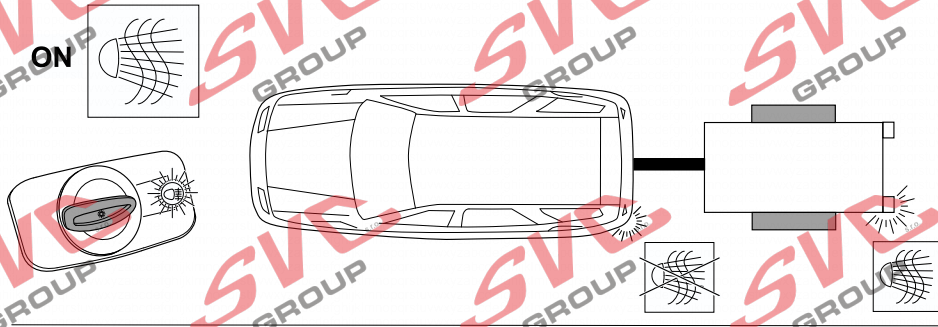

41

+

52

60

**OPTION 2**

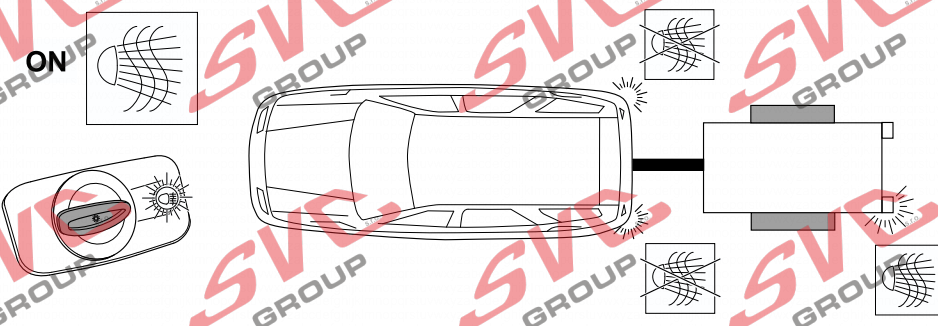

41

+

52

60

**OPTION 3**

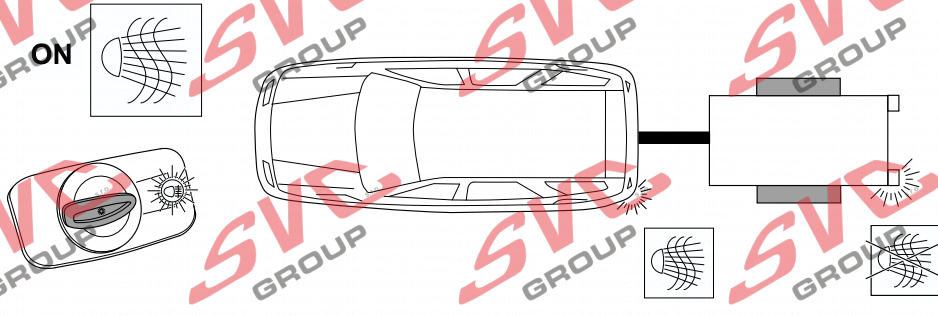

42

-

44

+

51

-

60

**OPTION 4**

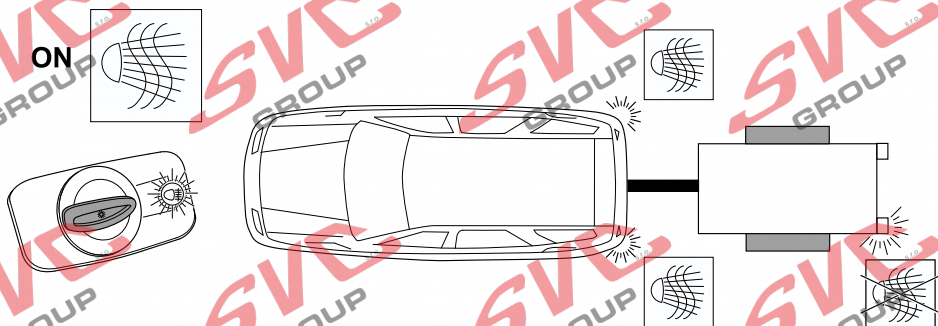

45

-

60

# 41 OPTION 1/2



17

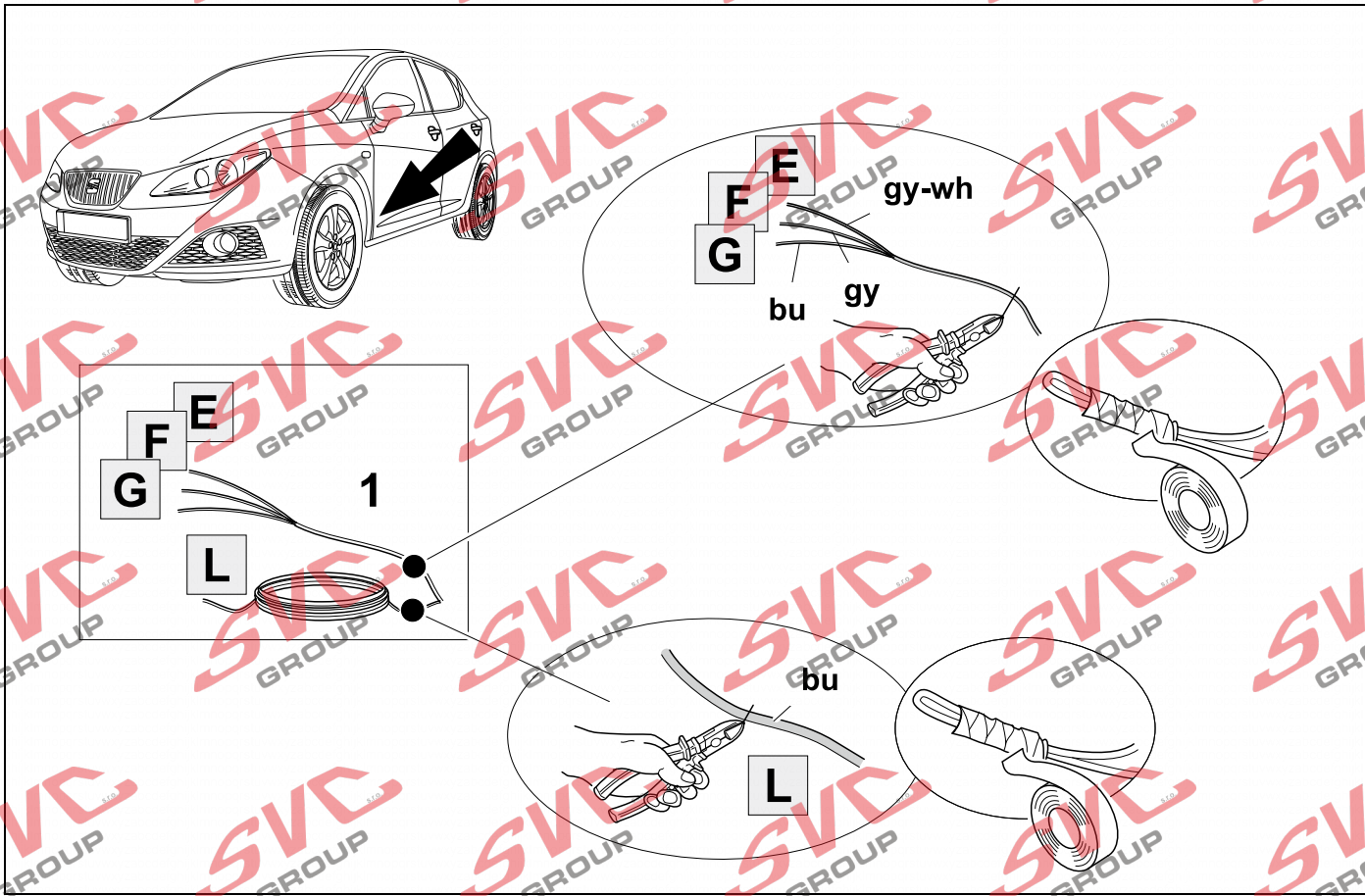

# 42 OPTION 3



17

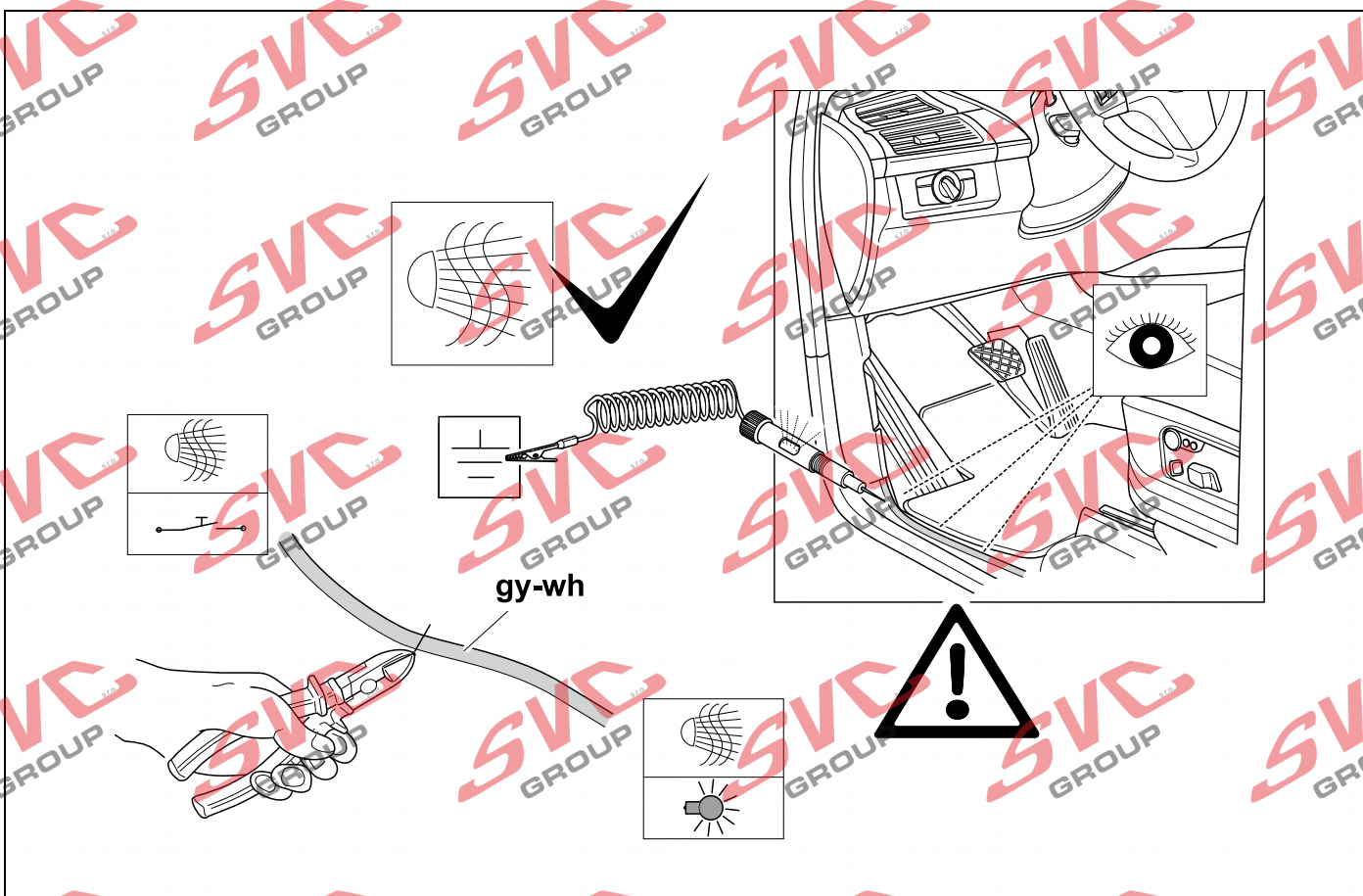



# 43 OPTION 3



17

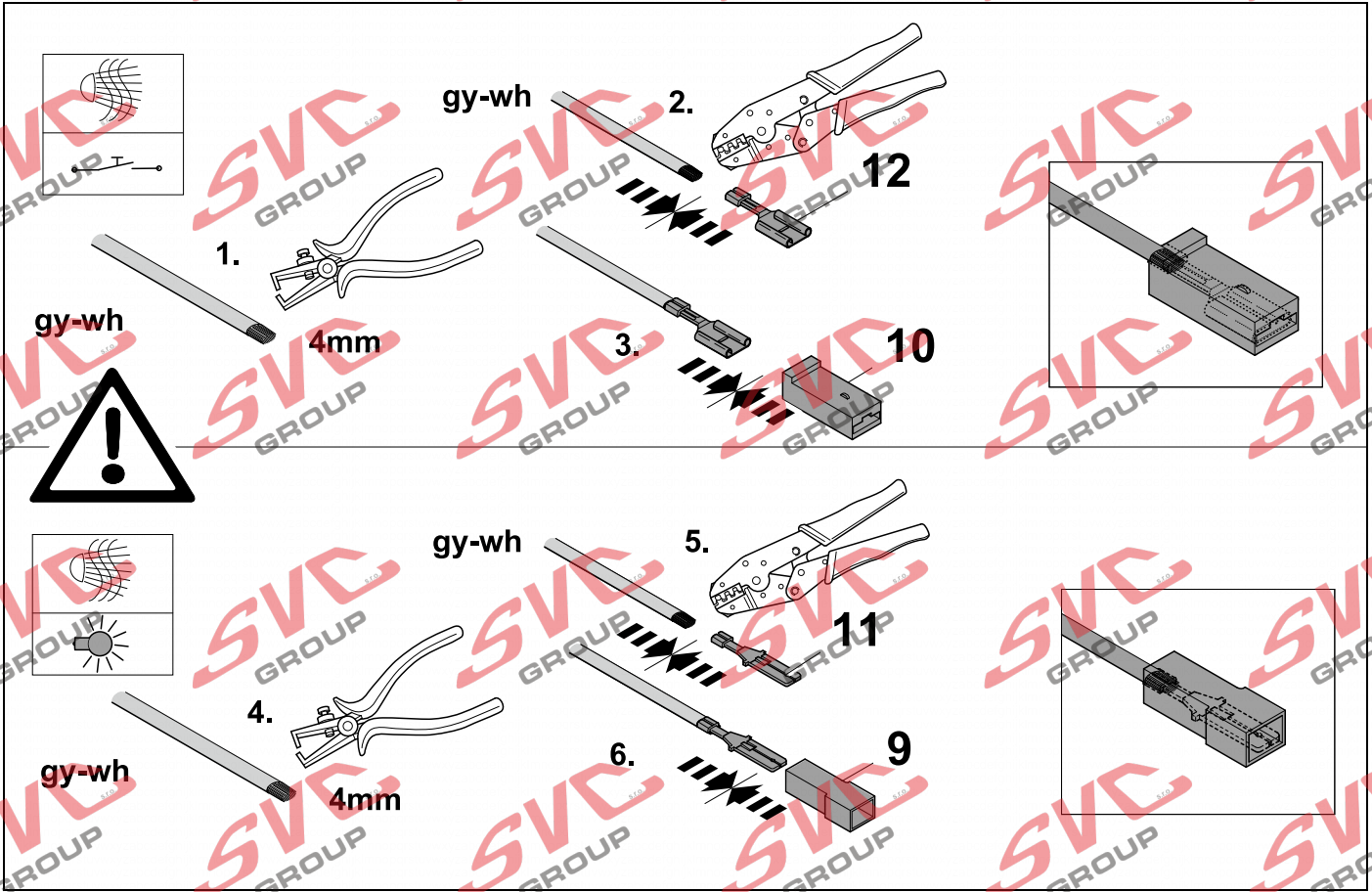

# 44 OPTION 3



17

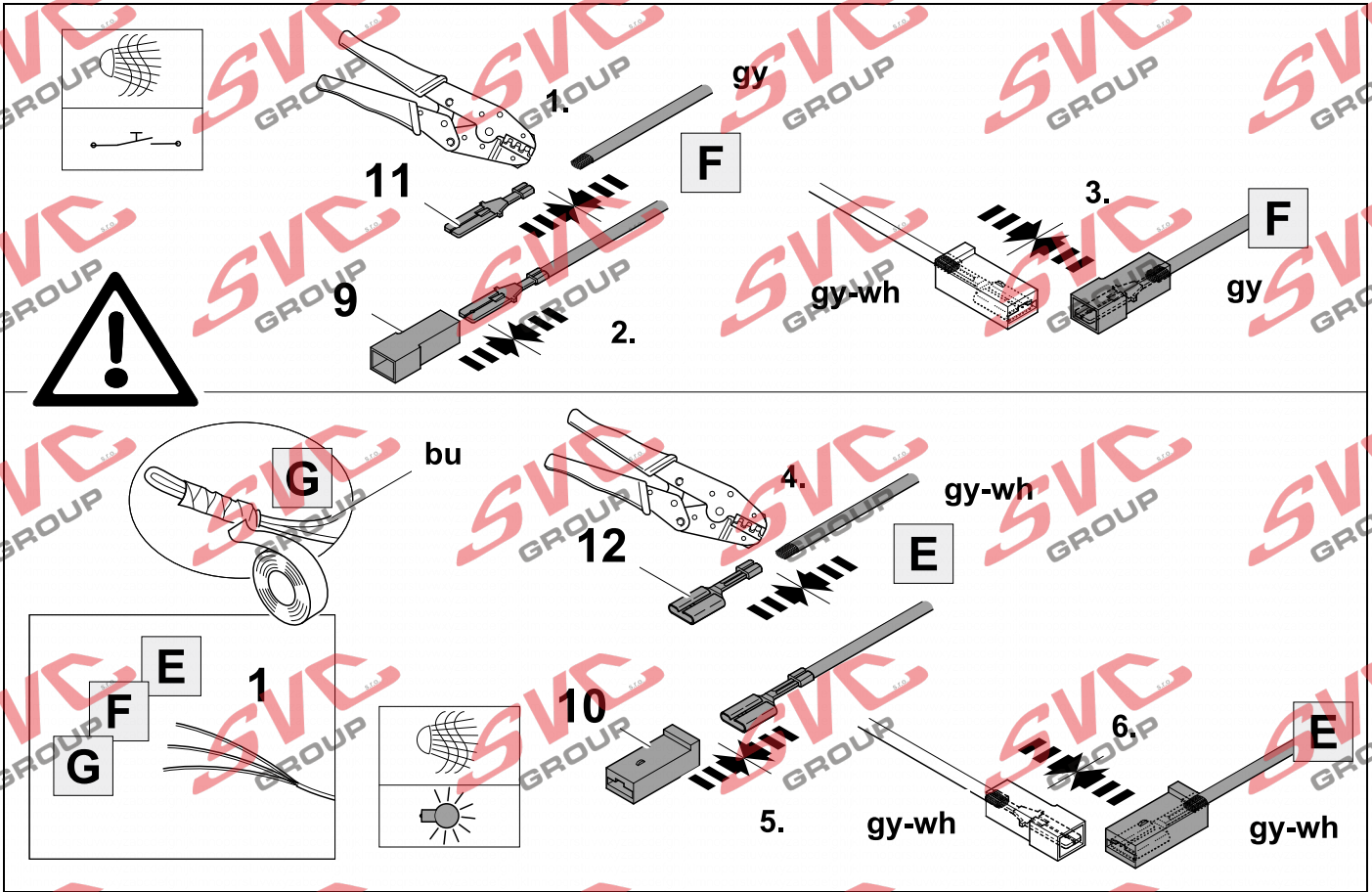

# 45 OPTION 4



17

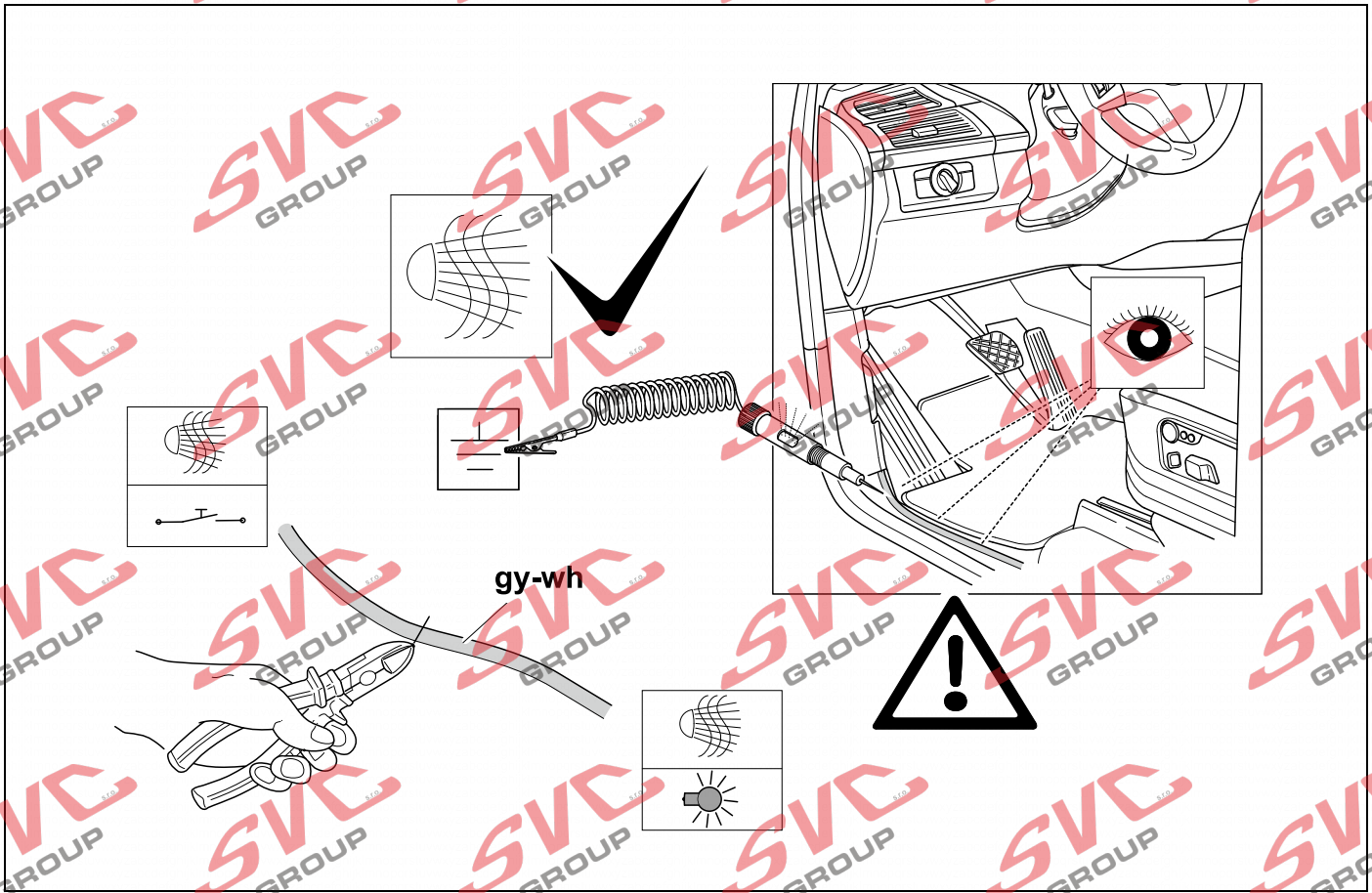

# 46 OPTION 4



17

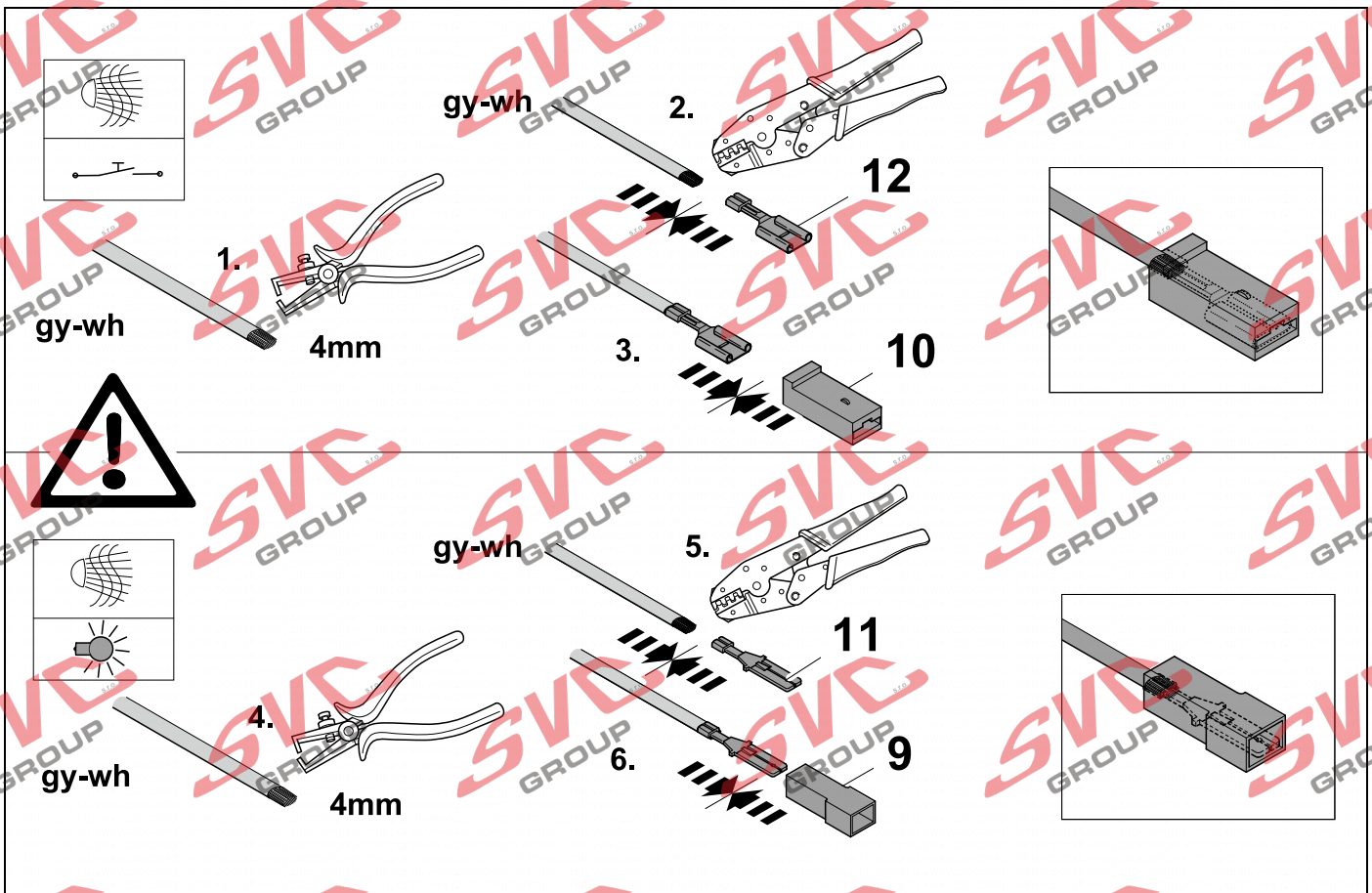



# 47 OPTION 4

17

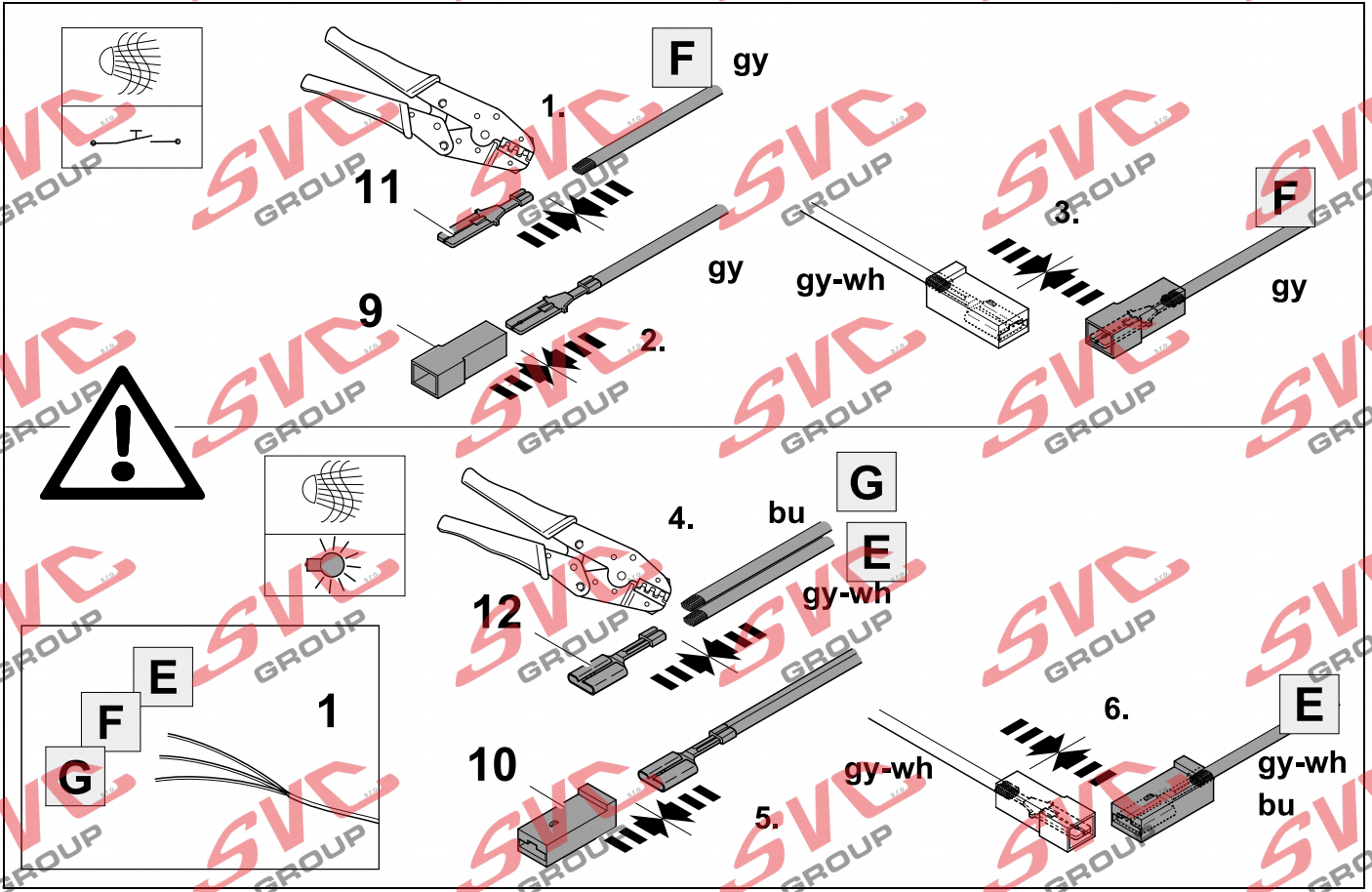

# 48 OPTION 4

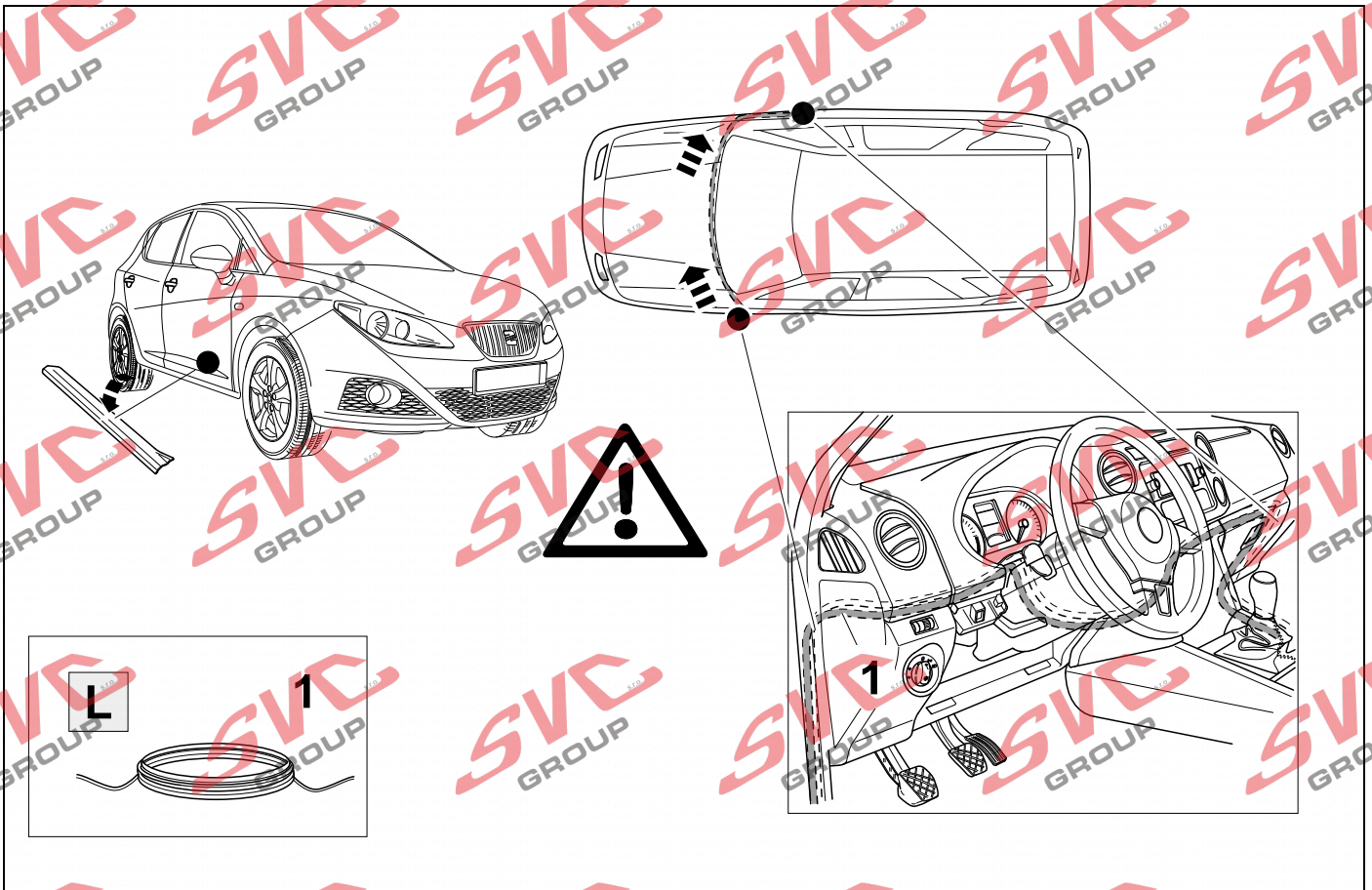

# 49 OPTION 4

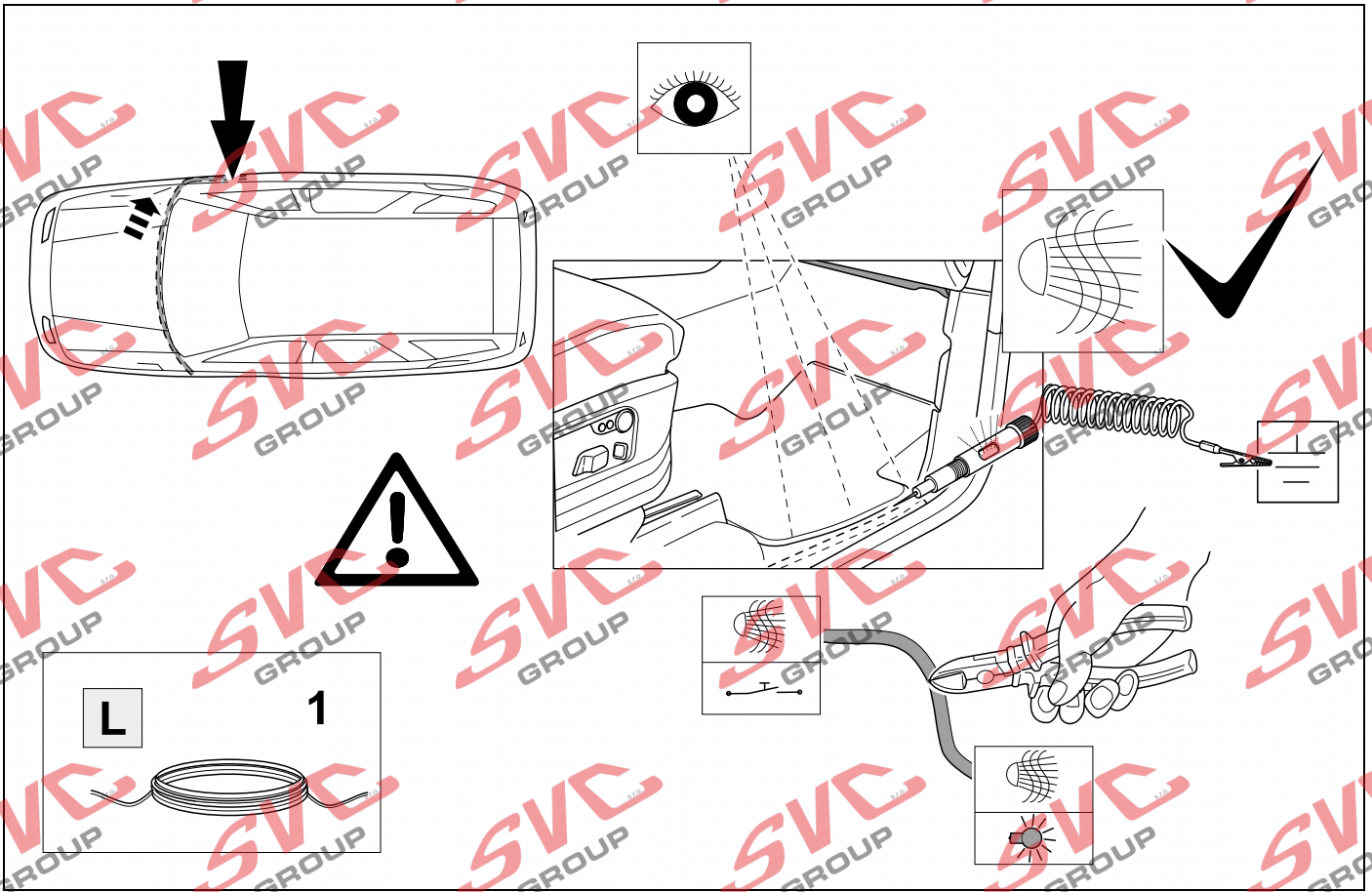

# 50 OPTION 4



17

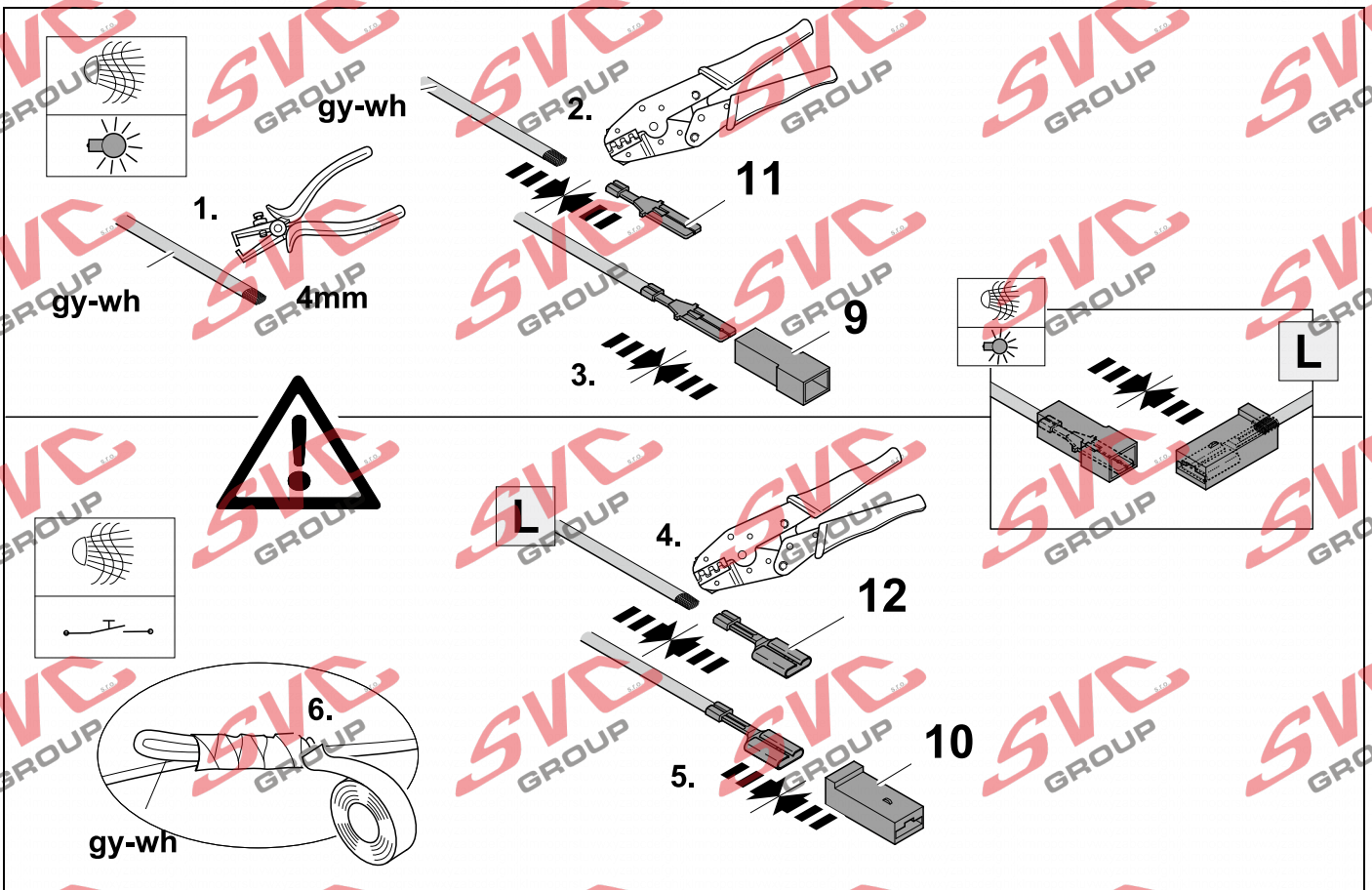



# 51 OPTION 3 / 4

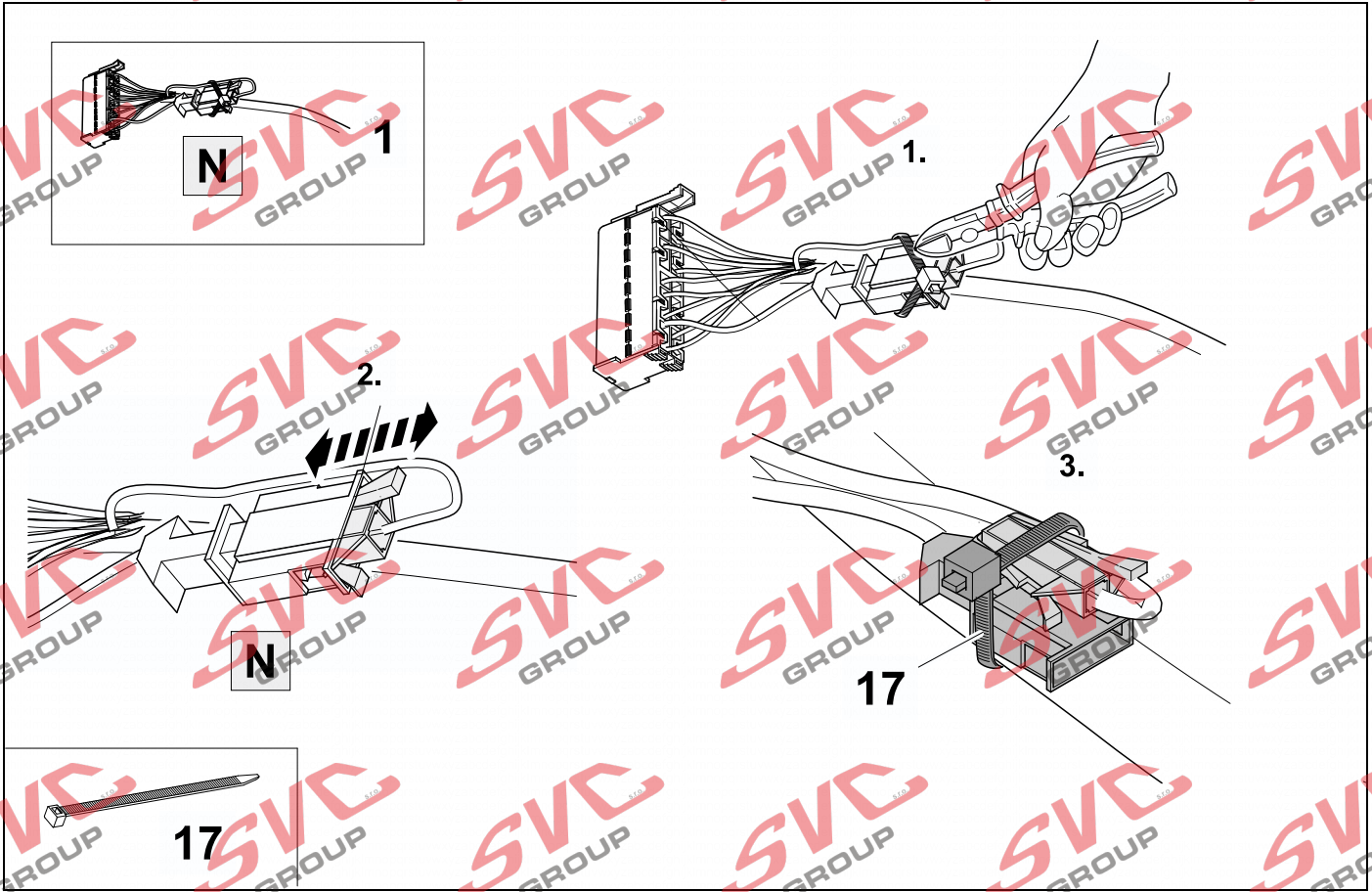

52



ERICH JAEGER Artikelnummer:  
ERICH JAEGER part number:

721075

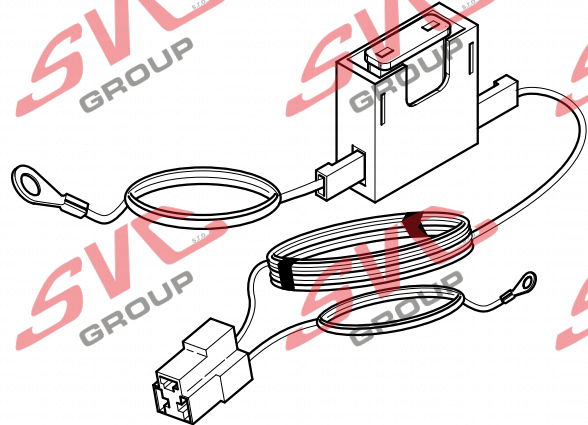
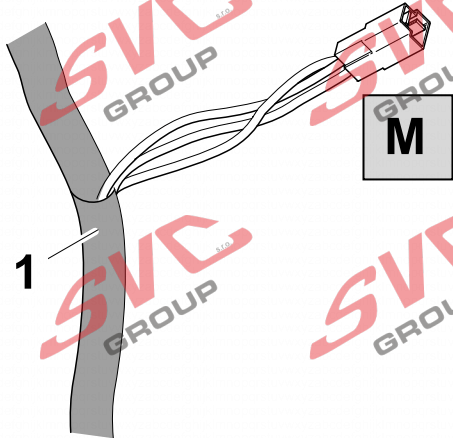

53



ERICH JAEGER Artikelnummer:  
ERICH JAEGER part number:

721077

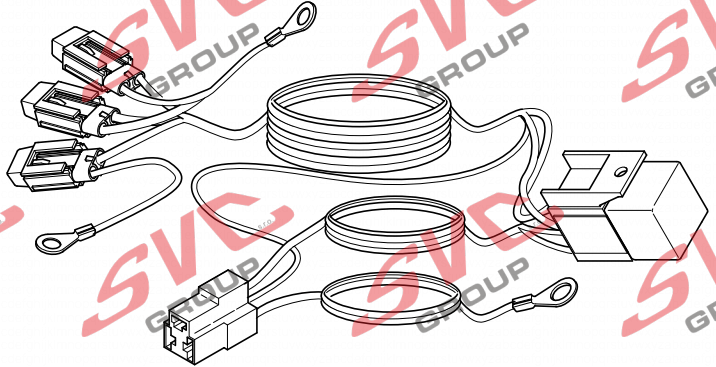
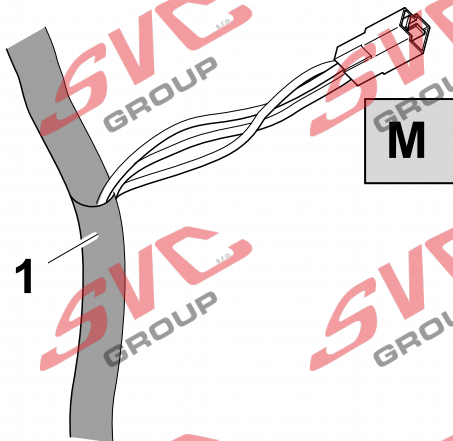



<p><b>(D)</b></p> <p>Folgende Beleuchtungsfunktionen des Anhängers werden nicht bei allen Zugfahrzeugen mit Tagesfahrlichtschaltung unterstützt:</p> <ul style="list-style-type: none"> <li>- <b>Schlussleuchten</b></li> <li>- <b>Begrenzungsleuchten</b></li> <li>- <b>Kennzeichenbeleuchtung</b></li> </ul> <p>Zur Aktivierung dieser Funktionen muss Stand oder Abblendlicht eingeschaltet werden!</p>	<p><b>(I)</b></p> <p>Le seguenti funzioni per l'illuminazione del rimorchio non sono supportate da tutte le motrici con circuito di luci diurne:</p> <ul style="list-style-type: none"> <li>- <b>luci posteriori</b></li> <li>- <b>luci d'ingombro</b></li> <li>- <b>illuminazione targa</b></li> </ul> <p>Per attivare queste funzioni devono essere accese le luci di posizione o gli anabbaglianti!</p>
<p><b>(GB)</b></p> <p>The following lamp functions for the trailer are not supported by all towing vehicles with DRL circuit:</p> <ul style="list-style-type: none"> <li>- <b>Rear lights</b></li> <li>- <b>Side lights</b></li> <li>- <b>Numberplate lights</b></li> </ul> <p>The parking lights or dimmed headlights must be switched on to activate this function!</p>	<p><b>(NL)</b></p> <p>De volgende verlichtingsfuncties van de aanhanger worden niet bij alle trekkende voertuigen met daglichtschakeling ondersteund:</p> <ul style="list-style-type: none"> <li>- <b>Achterlichten</b></li> <li>- <b>Spatbordlampen</b></li> <li>- <b>Kentekenverlichting</b></li> </ul> <p>Ter activering van deze functies moet parkeer- of dimlicht worden ingeschakeld!</p>
<p><b>(F)</b></p> <p>Les fonctions d'éclairage suivantes de la remorque ne sont pas activables sur tous les véhicules de traction équipés de feux de circulation de jour:</p> <ul style="list-style-type: none"> <li>- <b>Feux arrières</b></li> <li>- <b>Feux d'encombrement</b></li> <li>- <b>Éclairage de la plaque minéralogique</b></li> </ul> <p>Pour activer ces fonctions, les feux de position ou de croisement doivent être allumés!</p>	<p><b>(E)</b></p> <p>No todos los vehículos tractores con conmutación de luz de marcha diurna ofrecen un soporte para las siguientes funciones de iluminación del remolque:</p> <ul style="list-style-type: none"> <li>- <b>Luces traseras</b></li> <li>- <b>Luces de galibo</b></li> <li>- <b>Iluminación de la matrícula</b></li> </ul> <p>¡Para activar estas funciones deberán encenderse las luces de posición o las luces de cruce!</p>

## 55 CHECK

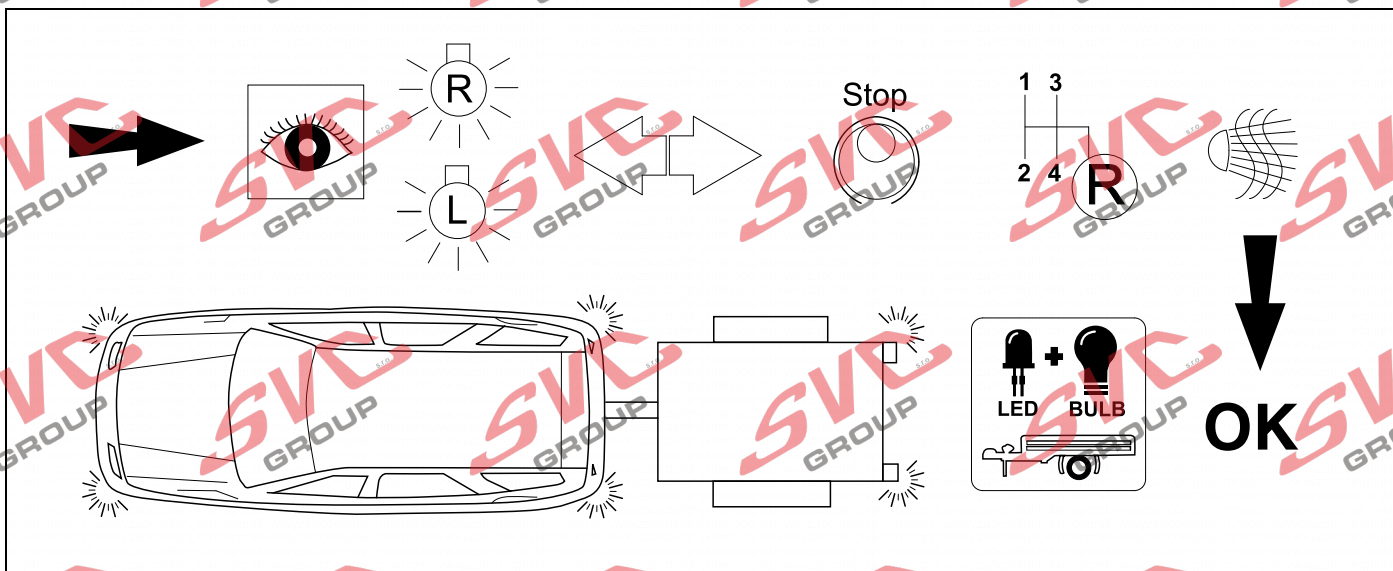

# 56 CHECK

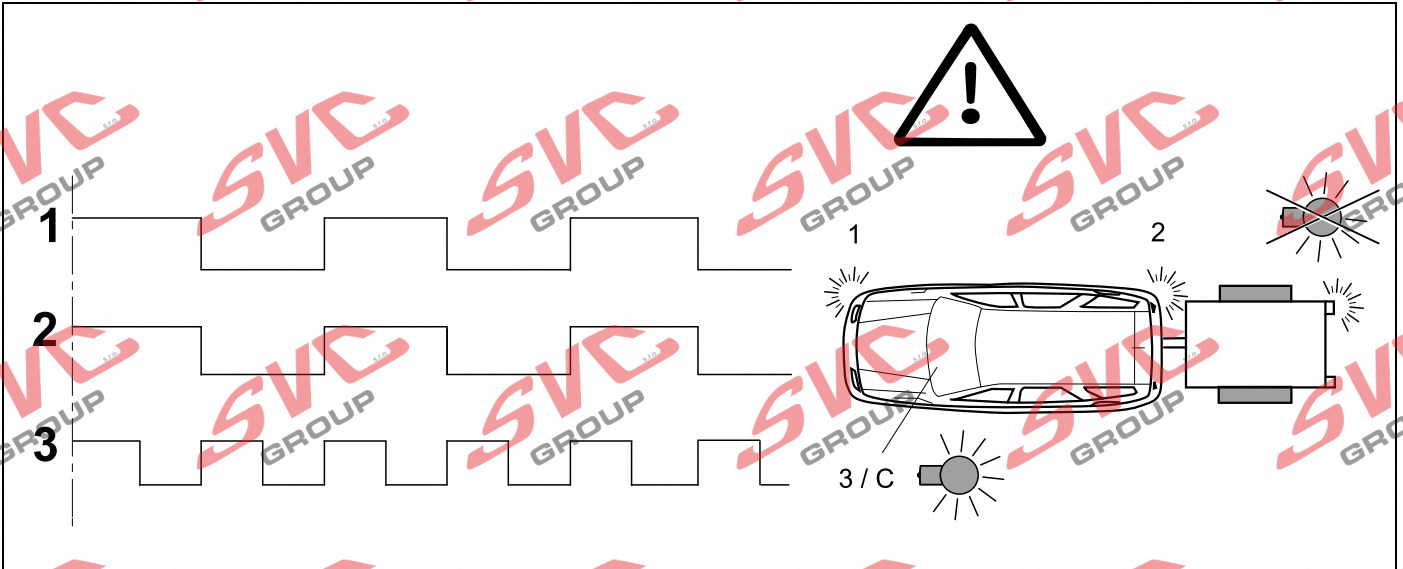

# 57 CHECK OPTION ORIGINAL PDC

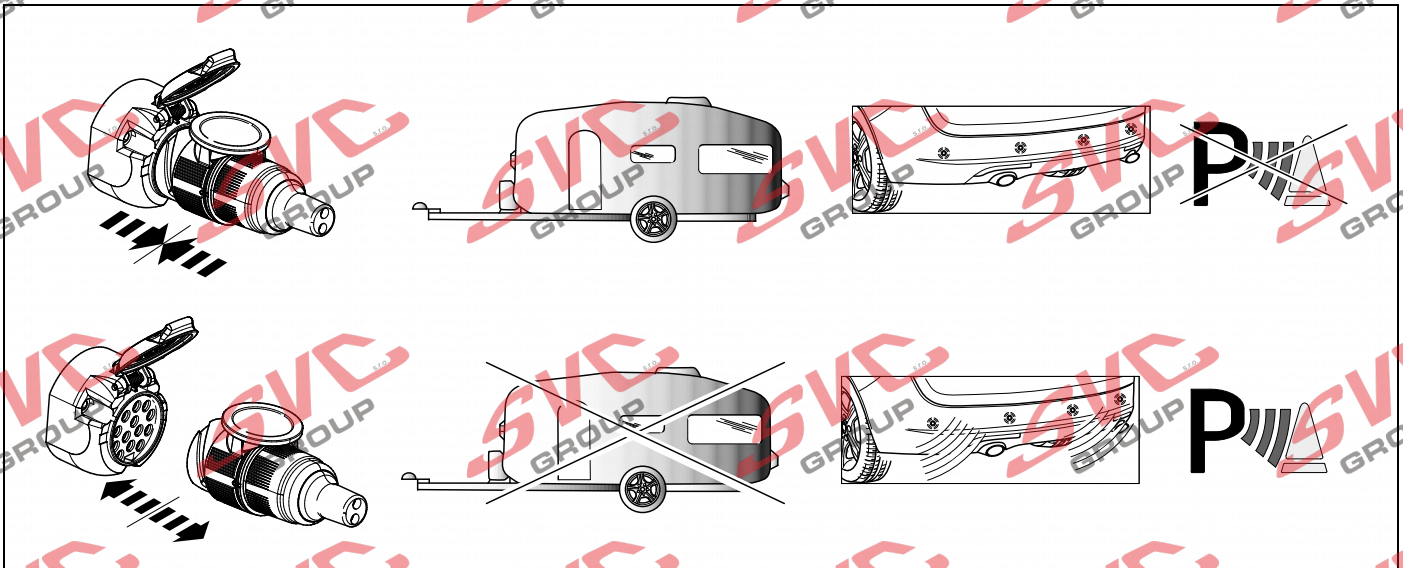

# 58 Information Service



34 + 37

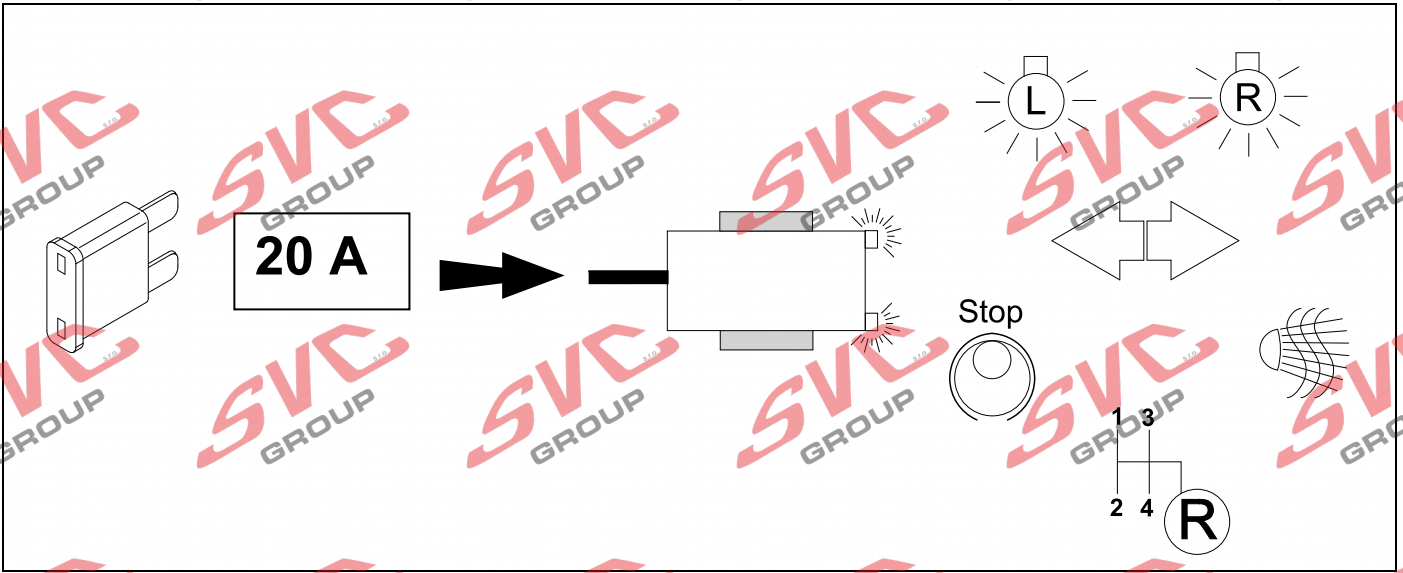



59

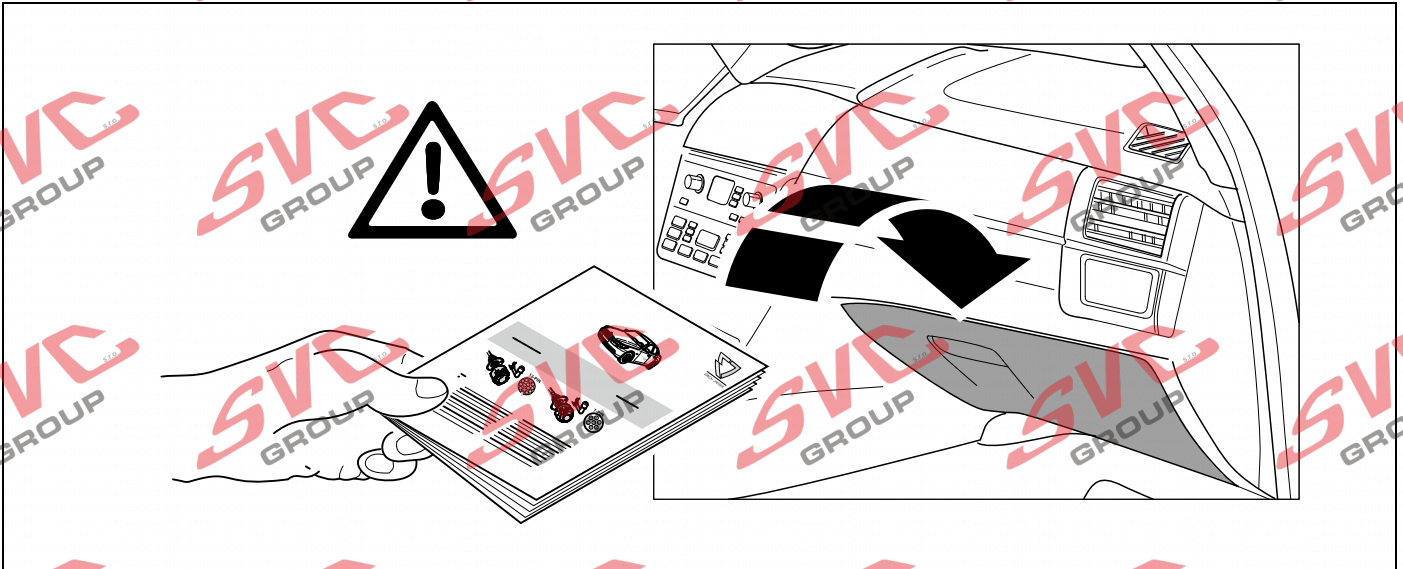

60

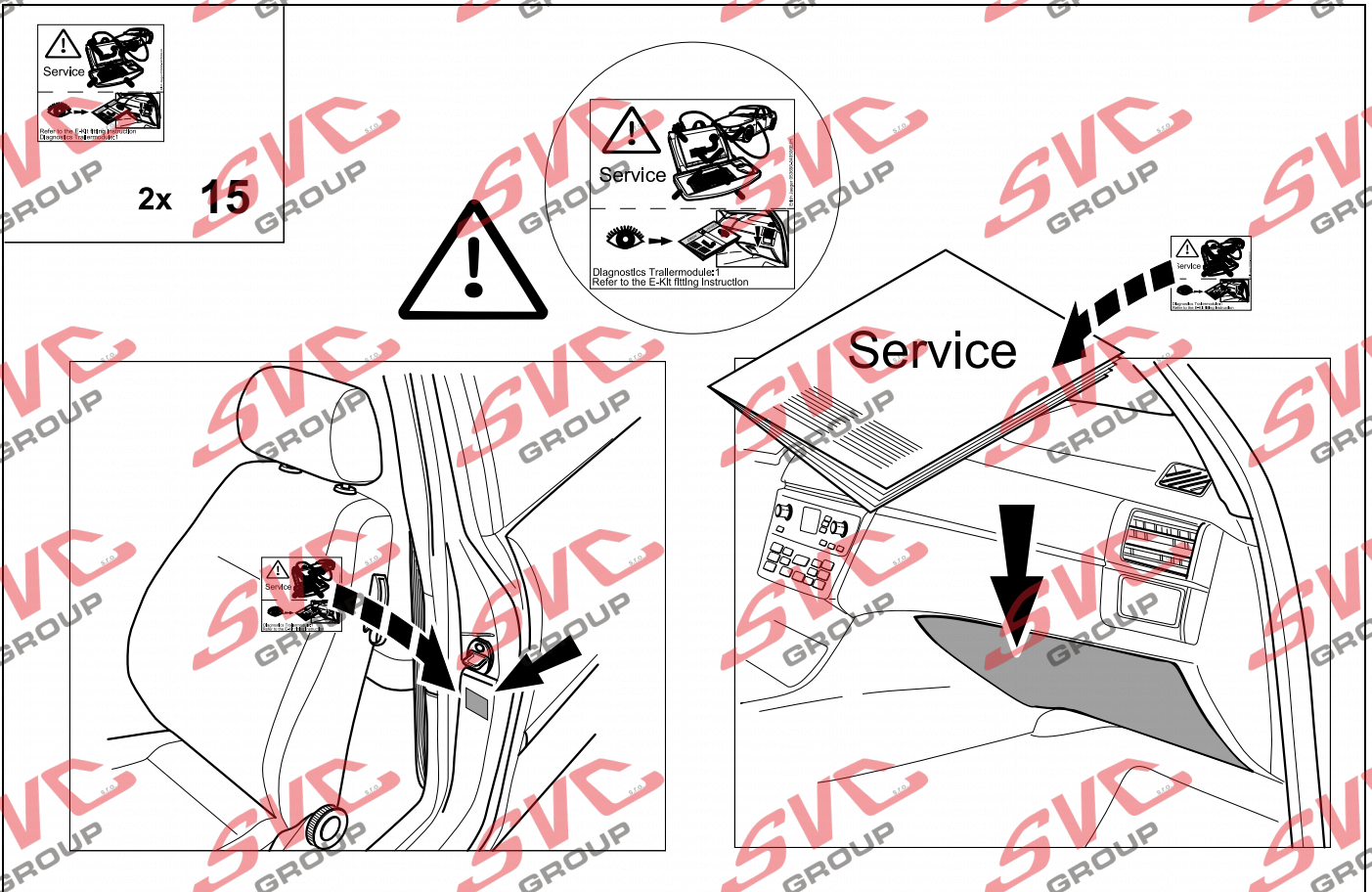

<b>D</b>	Änderungen bezüglich Konstruktion, Ausstattung Farbe sowie Irrtum vorbehalten. Angaben und Abbildungen unverbindlich	<b>PL</b>	Zastrzega się prawo do zmian dot. konstrukcji, wykończenia, kolorystyki oraz pomylek. Dane i ilustracje niewiążące.
<b>GB</b>	Subject to change in terms of construction, equipment and colour, and may contain errors. The information and illustrations are non-binding.	<b>TR</b>	Tasarım, donanım ve renk bakımından değişiklik yapma hakkı ve hata ve eksiklik mahfuzdur. Veriler ve resimler bağlayıcı değildir.
<b>F</b>	Sous réserve de modifications de la construction, de équipement, de la couleur et sous réserve d'erreurs. Les indications et les illustrations sont sans engagement.	<b>H</b>	A szerkezet, a kivitelt és a szín változtatása, valamint a változások joga fenntartva. Az adatok és az ábrák nem kötelező érvényűek.
<b>NL</b>	Wijzigingen met betrekking tot constructie, uitvoering en kleur evenals vergissingen voorbehouden. Gegevens en afbeeldingen niet bindend.	<b>HR</b>	Pravo promjena u svezi konstrukcije, opreme, boje kao i zabune oviđavamo. Podaci i ilustracije su neobavezne.
<b>DK</b>	Ændringer med hensyn til konstruktion, udstyr, farver samt fejl forbeholdes. Oplysninger og illustrationer er uforpligtende.	<b>BUL</b>	Запазени права по отношение на конструкцията, оборудването, цвета и грешки. Данните и изображенията не са обвързващи.
<b>N</b>	Ændringer angående konstruksjon, utstyr, farge og feiltagelse forbeholdes. Oplysninger og illustrasjoner uforbindtlig.	<b>RO</b>	Ne rezervăm dreptul unor modificări ale construcției, dotării, culorii și dreptul la erori Datele indicate și imaginile sunt orientative.
<b>S</b>	Med reservation för ändringar vad det gäller konstruktion, utrustning, färg samt för misstag. Uppgifterna och bilderna är inte bindande.	<b>RU</b>	Права на внесение изменений относительно конструкции, оснащения, окраски, а также на ошибки сохраняются. Данные и иллюстрации имеют примерный характер.
<b>FIN</b>	Pidätämme oikeuden rakennetta, varustusta, väriä koskeviin sekä erehdyksestä johtuviin muutoksiin. Tiedot ja kuvat eivät ole sitovia.	<b>LT</b>	Pasilieikama konstrukcijos, įrangos bei reikmenų, spalvos pakeitimų ir klaidų teisė. Duomenys ir iliustracijos neįpareigojantys.
<b>I</b>	Con riserva di modifiche relative a progettazione, dotazione, colore ed errori. Le indicazioni e figure sono fornite senza impegno.	<b>LV</b>	Tiek paturētas tiesības uz konstrukcijas, iekārtu, krāsu izmaiņām, kā arī kļūdišanās. Dati un attēli bez saistībām.
<b>E</b>	Reservadas las modificaciones respecto a diseño, equipamiento, color, así como error. Indicaciones y figuras sin compromiso.	<b>EST</b>	Konstruktsiooni, varustuse ja varvi osas muudatused ning eksimine lubatud. Andmed ja joonised on mittesiduvad.
<b>P</b>	Reservamos o direito de alterações relativamente ao desenho, equipamento, cor, bem como de erro. Os dados e as gravuras não implicam compromisso da nossa parte.	<b>SLO</b>	Zadržana pravica do sprememb glede konstrukcije, opreme, barve ter pomote. Podatki in slike so neobvezne.
<b>GR</b>	Διατηρώνουμε κάθε επιφύλαξη ως προς αλλαγές σε σχέση με κατασκευή, εξοπλισμό, διαρρύθμιση, χρωματισμούς και λάθη παραδρομής.	<b>SK</b>	Zmeny, ktoré sa týkajú konštrukcie, vybavenia, farby, ako aj omyly sú vyhradené. Údaje a zobrazenia sú nezáväzné.
<b>CZ</b>	Změny, týkající se konstrukce, vybavení, barvy, jakož i omyly jsou vyhrazeny. Údaje a vyobrazení jsou nezávazné.		

