

# Montážní návod

(Montážny návod, Fitting instruction, Montageanleitung,  
Istruzioni di montaggio, Monteringshandledning,  
Asennusohje, Instruction de montage,  
Montegehandleiding, Инструкция по установке)



## Elektropřípojka Citroën C4 11/2004->07/2011

Elektropřípojka  
Wiring kit  
Trekhaakkabelset  
E-satz  
Faisceau D'attelage  
Barra de remolque  
Wiązka elektryczna  
Vetokoukun vaijerisarja  
Гачковий джгут



výrobce / dodavatel

**SVC Group s.r.o.**

Odkaz na produkt:

<https://www.svcgroup.cz/tazne-zarizeni-sro-uby-pevny-skoda-rapid-monte-carlo-10-2012-2018-p7283-v960>



[www.svcgroup.cz](http://www.svcgroup.cz)



ERICH JAEGER

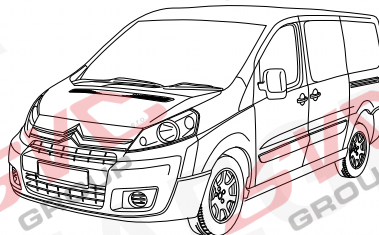
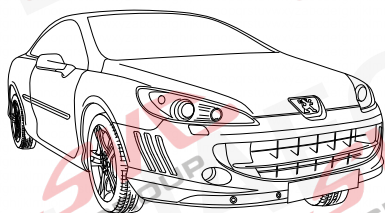
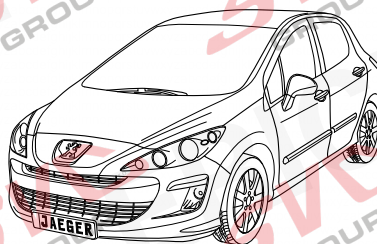
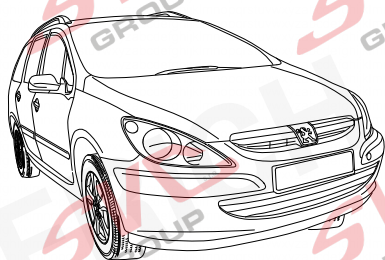

PEUGEOT 307 / SW / Break / CC

05/05 >>

PEUGEOT 308 / SW

09/07 >> 10/08

PEUGEOT 407 / SW / Coupé

05/04 >>

PEUGEOT Expert / CITROEN Jumpy

01/07 >> 06/16

FIAT Scudo

01/07 >>

736941

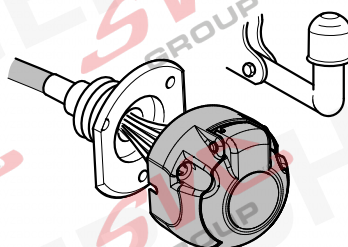

7-PIN

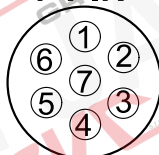

ISO 1724

748841

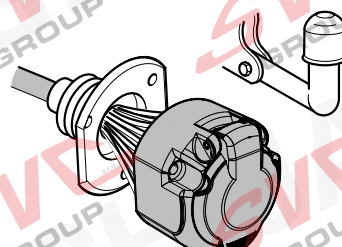

13-PIN

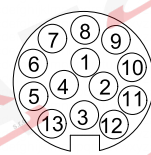

ISO 11446

- (D) Einbauanleitung
- (GB) Installation instructions
- (F) Consignes de montage
- (NL) Montagehandleiding
- (DK) Montagevejledning
- (N) Monteringsinstruksjon
- (S) Installationsanvisning
- (FIN) Asennusohje
- (I) Istruzioni per il montaggio
- (E) Instrucciones de montaje
- (P) Instruções de montagem
- (GR) Οδηγίες εγκατάστασης
- (CZ) Návod k montáži

- (PL) Instrukcja montażu
- (TR) Montaj talimatı
- (H) Beépítési útmutató
- (HR) Upute o ugradnji
- (BUL) Инструкция за монтаж
- (RO) Instrucțiuni de montaj
- (RU) Инструкция по монтажу и установке
- (LT) Montavimo informacija
- (LV) Iemontēšanas pamācība
- (EST) Paigaldusjuhend
- (SLO) Navodilo za vgradnjo
- (SK) Montážny návod

<p style="text-align: center;"><b>D</b></p>	<p style="text-align: center;"><b>Hinweis:</b></p> <p>Nach dem Einbau des Elektro-Einbausatzes muss die Funktionserweiterung auf Anhängerbetrieb gemäß der Diagnoseanweisung des Fahrzeugherstellers programmiert werden.</p> <p>Gegebenenfalls müssen weitere Fahrzeugsysteme (z.B. Einparkhilfe) separat auf die Ausstattungsvariante „Anhängerbetrieb“ codiert werden.</p> <p>Das Anhänger-Steuergerät ist nicht diagnosefähig, wodurch es zu Einträgen im Diagnoseprotokoll in Verbindung mit dem Anhänger-Steuergerät kommen kann.</p>
<p style="text-align: center;"><b>GB</b></p>	<p style="text-align: center;"><b>Reference:</b></p> <p>After the electrical insert kit has been built-in, the functional addition must be programmed to trailer operation according to the diagnosis instruction of the vehicle manufacturer. If necessary further vehicle systems (e.g. parking aids) must be separately code to the equipment variant "trailer operation". The trailer steering device is not diagnosis capable, which can lead to entries in the diagnosis protocol in conjunction with the steering device of the trailer.</p>
<p style="text-align: center;"><b>F</b></p>	<p style="text-align: center;"><b>Remarque :</b></p> <p>Après montage du faisceau, effectuer les opérations de programmation du véhicule pour le mode remorquage selon les instructions de diagnostic données par le constructeur.</p> <p>Le cas échéant certains systèmes additionnels (p.ex. l'aide au parking) doivent être codés spécifiquement en « mode remorque » dans le menu des différents équipements.</p> <p>Le calculateur de remorque ne peut pas être diagnostiqué, ce qui peut provoquer des inscriptions dans le protocole du diagnostic en liaison avec le calculateur.</p>
<p style="text-align: center;"><b>NL</b></p>	<p style="text-align: center;"><b>Opmerking:</b></p> <p>Na de inbouw van het elektrische inbouwpakket moet de functie-uitbreiding naar aanhangwagenbedrijf overeenkomstig de diagnose-instructie van de voertuigfabrikant worden geprogrammeerd.</p> <p>Eventueel dienen andere voertuigsystemen (bijv. inparkeerhulp) apart voor de uitrustingsvariant "aanhangwagenbedrijf" worden gecodeerd.</p> <p>Het aanhangwagenregelapparaat is niet in staat tot diagnoses, waardoor het in het diagnoserapport tot vermeldingen in verband met het aanhangwagenregelapparaat kan komen.</p>
<p style="text-align: center;"><b>DK</b></p>	<p style="text-align: center;"><b>Henviisning:</b></p> <p>Efter montering af elektro-montagesættet skal funktionsudvidelsen programmeres til anhængerdrift iht. køretøjproducentens diagnoseanvisning.</p> <p>I givet fald skal yderligere køretøjsystemer (f.eks. parkeringshjælp) kodes separat til udstyrsvariant „anhængerdrift“.</p> <p>Anhænger-styreenheden er ikke diagnosticedygtig, hvorigenem der kan forekommer noteringer i diagnoseprotokollen i forbindelse med anhænger-styreenheden.</p>
<p style="text-align: center;"><b>N</b></p>	<p style="text-align: center;"><b>Henviisning:</b></p> <p>Etter montering av det elektroniske monteringssettet må funksjonsutvidelsen programmeres på tilhengerdrift iht. diagnosehenviisningen til kjøretøysprodusenten.</p> <p>Eventuelt må ytterligere kjøretøyssystemer (f.eks. parkeringshjelp) kodes separat på utrustningsvariant "tilhengerdrift".</p> <p>Tilhengerstyreapparatet har ingen diagnoseevne, noe som kan føre til innføring i diagnoseprotokollen i forbindelse med tilhengerstyreapparatet.</p>
<p style="text-align: center;"><b>S</b></p>	<p style="text-align: center;"><b>Anm:</b></p> <p>När den elektriska inbyggnadssatsen har monterats, måste man programmera funktionsutökningen till släpdrift enligt diagnosinstruktionerna från fordonstillverkaren.</p> <p>Ev. behöver ytterligare fordonssystem (t.ex. parkeringshjäl) kodas separat på utrustningsvarianten "Släpvagnsdrift".</p> <p>Släpstyrenheten kan inte diagnostiseras, och av den anledningen kan uppgifter läggas in i diagnosloggen i samband med släpstyrenheten.</p>
<p style="text-align: center;"><b>FIN</b></p>	<p style="text-align: center;"><b>Huomautus:</b></p> <p>Sähköasennussarjan asennuksen jälkeen ohjainlaite on ohjelmoitava perävaunun käyttöön ajoneuvon valmistajan diagnoosiohjeita noudattaen.</p> <p>Tarvittaessa muut ajoneuvojärjestelmät (esim. pysäköintiapu) on koodattava "perävaunun käyttöön" erikseen.</p> <p>Perävaunun ohjainlaite ei ole diagnoosikelpoinen, minkä johdosta diagnoosiraporttiin voi tulla perävaunun ohjainlaitteeseen liittyviä merkintöjä.</p>
<p style="text-align: center;"><b>I</b></p>	<p style="text-align: center;"><b>Avvertenza:</b></p> <p>Dopo il montaggio del set di installazione elettrico è necessario programmare l'ampliamento delle funzioni per la modalità di funzionamento rimorchio secondo l'indicazione di diagnosi del produttore del veicolo.</p> <p>Eventuali sistemi aggiuntivi del veicolo (p. es. aiuto parcheggio) devono essere codificati separatamente sulla variante di dotazione „modalità di funzionamento rimorchio“.</p> <p>Il dispositivo di controllo rimorchio non è abilitato per la diagnosi, quindi potrebbero verificarsi immissioni nel protocollo di diagnosi in relazione al dispositivo di controllo rimorchio.</p>

<p style="text-align: center;"><b>(E)</b></p>	<p style="text-align: center;"><b>Advertencia:</b></p> <p>Tras haber instalado el juego de montaje eléctrico se tiene que programar la ampliación de la función a servicio de remolque conforme a las instrucciones de diagnóstico del fabricante del vehículo.</p> <p>Si se precisa, otros sistemas de vehículos (p.ej., ayudante para aparcar) tienen que codificarse aparte a la variante de equipamiento "servicio de remolque".</p> <p>El equipo de control del remolque no es susceptible de diagnosticar, por lo cual pueden producirse registros en el protocolo de diagnósticos en combinación con el equipo de control del remolque</p>
<p style="text-align: center;"><b>(P)</b></p>	<p style="text-align: center;"><b>Aviso:</b></p> <p>Após a montagem do conjunto eléctrico de montagem, a ampliação funcional sobre a operação de reboque deverá ser programada conforme a instrução de diagnóstico do fabricante do veículo.</p> <p>Caso necessário, devem ser codificados outros sistemas de veículo (p.ex. assistência de estacionamento) separadamente sobre a variante de equipagem „Operação de reboque“.</p> <p>O aparelho de controlo do reboque não é passível de diagnóstico, conquanto pode entrar em ligação com o aparelho de controlo do reboque para registos no protocolo de diagnóstico.</p>
<p style="text-align: center;"><b>(GR)</b></p>	<p style="text-align: center;"><b>Υπόδειξη:</b></p> <p>Μετά την τοποθέτηση του ηλεκτρικού εξαρτήματος πρέπει να προγραμματισθεί η επέκταση της λειτουργίας σε λειτουργία με ρυμουλκούμενο σύμφωνα με την υπόδειξη διάγνωσης του κατασκευαστή του αυτοκίνητου.</p> <p>Ενδεχομένως πρέπει να κωδικοποιηθούν και άλλα συστήματα του αυτοκίνητου (π.χ. βοήθεια στάθμευσης) ξεχωριστά για τον εξοπλισμό „Λειτουργία ρυμουλκούμενου“.</p> <p>Η συσκευή ελέγχου του ρυμουλκούμενου δεν μπορεί να υποβληθεί σε διάγνωση και γιαυτό δεν αποκλείονται εγγραφές στο πρωτόκολλο διάγνωσης σε συνδυασμό με τη συσκευή ελέγχου του ρυμουλκούμενου.</p>
<p style="text-align: center;"><b>(CZ)</b></p>	<p style="text-align: center;"><b>Pokyn:</b></p> <p>Po vestavění elektrické sady pro vestavbu, musí být naprogramované rozšíření funkcí pro provoz s přívěsem, podle diagnostického pokynu výrobce vozidla.</p> <p>Případně se musí další systémy vozidla (např. pomocné zařízení pro zaparkování) zvlášť zakódovat do varianty vybavení „Provoz s přívěsem“.</p> <p>Řídící zařízení přívěsu není diagnosticky schopné, tím pak může dojít k záznamům v diagnostickém protokolu ve spojení s řídicím přístrojem přívěsu.</p>
<p style="text-align: center;"><b>(PL)</b></p>	<p style="text-align: center;"><b>Wskazówka:</b></p> <p>Po montażu elektrycznego zestawu montażowego należy zaprogramować poszerzenie funkcji na jazdę z przyczepą zgodnie z instrukcją diagnostyczną producenta pojazdu.</p> <p>W razie potrzeby należy zakodować dalsze systemy pojazdów (np. ultradźwiękowy system nadzorujący parkowanie) na wariant wyposażenia „jazda z przyczepą“.</p> <p>Urządzenie sterujące przyczepą jest możliwe do diagnozowania, dzięki czemu w powiązaniu z tym urządzeniem może dojść do dokonania wpisów w protokole diagnostycznym.</p>
<p style="text-align: center;"><b>(TR)</b></p>	<p style="text-align: center;"><b>Bilgi:</b></p> <p>Elektrikli montaj seti monte edildikten sonra fonksiyon genişletmesinin, araç imalatçısının arıza teşhis talimatlarına göre römork işletmesine programlanması gerekmektedir.</p> <p>Gerektiğinde daha başka araç sistemlerinin de (örn. park etme yardımı), ayrı olarak "Römork işletmesi" donatım çeşidine kodlanması gerekmektedir.</p> <p>Römork kumanda aletinin arıza teşhis kabiliyeti yoktur, bu nedenle römork kumanda aleti ile bağlantılı olarak arıza teşhis protokolüne kayıtlar işlenmemektedir.</p>
<p style="text-align: center;"><b>(H)</b></p>	<p style="text-align: center;"><b>Utalás:</b></p> <p>Az elektromos beépíthető garnitúra beszerelésé után a bővített működésti pótkocsi üzemeltetésre kell programozni a járműgyártó útmutatásainak megfelelően.</p> <p>Adott esetben további járműrendszereket (pl. parkolási segítség) külön kell kódolni a „pótkocsiműködés” felszerelési variánsára.</p> <p>A pótkocsi vezérlő készülékét nem lehet diagnosztizálni, ezért a diagnosztizálás során a pótkocsi-vezérlő készülékkel kapcsolatban bejegyzésekre kerülhet sor.</p>
<p style="text-align: center;"><b>(HR)</b></p>	<p style="text-align: center;"><b>Uputa:</b></p> <p>Nakon ugradnje elektroinstalacijskog seta treba programirati proširenje funkcije na pogon prikolice u skladu s dijagnostičkim uputama proizvođača vozila. U danom slučaju potrebno je posebno kodirati daljnje sustave vozila (npr. pomoć pri parkiranju) na varijantu opreme „pogon prikolice“.</p> <p>Kontrolna jedinica prikolice nije podobna za dijagnozu, pri čemu može doći do unosa u dijagnostički zapisnik u vezi s kontrolnom jedinicom prikolice.</p>

<p><b>(BUL)</b></p>	<p><b>Указание:</b> След вграждането на електромонтажния комплект разширяването на функциите, обхващащо и работата на ремаркетото трябва да бъде програмирано в съответствие с ръководството за диагностика на производителя на автомобила. Евентуално и други системи на автомобила (например помощ при паркиране) трябва да бъдат кодирани поотделно на варианта оборудване „работа на ремаркетото“. Уредът за управление на ремаркетото не може да бъде диагностициран, поради което може да се стигне до вписвания в протокола за диагностика, свързани с уреда за управление на ремаркетото.</p>
<p><b>(RO)</b></p>	<p><b>Indicație:</b> După montarea înăuntru a garniturii electrice, funcționarea extinsă trebuie programată pe funcționarea remorcii, după instrucțiunile producătorului de vehicule. Eventual, alte sisteme de vehicule (de ex. ajutor la parcare) trebuie codate separat pe varianta de echipament „funcționarea remorcii”. Aparatul de reglaj al remorcii nu poate fi diagnosticat, de aceea în protocolul de diagnostice în legătură cu aparatul de reglaj al remorcii, pot urma înregistrări.</p>
<p><b>(RU)</b></p>	<p><b>Указание:</b> После установки электрического блока необходимо запрограммировать расширение функций на эксплуатацию автомобиля с прицепом согласно диагностической инструкции завода-изготовителя транспортного средства. В случае необходимости другие системы автомобиля (напр., парковочная система) должны быть отдельно закодированы на вариант „Эксплуатация автомобиля с прицепом“. Устройство управления прицепом невозможно диагностировать, из-за чего в диагностическом протоколе могут появиться записи, касающиеся устройства управления прицепом.</p>
<p><b>(LT)</b></p>	<p><b>Nuoroda:</b> Įmontavus elektroindikacijų bloką, skirtą transporto priemonės ištaisymo sistemos kontrolei, reikia užprogramuoti daugiau funkcijų priekabos eksploatacijai, remiantis transporto priemonės gamintojo techninės diagnostikos instrukcija. Atsižvelgiant į aplinkybes, reikėtų papildomai užkoduoti kitus transporto priemonės įrenginius (pvz. transporto priemonės parkavimo radarą) ant atitinkamo priekabos modelio. Transporto priemonės priekabos valdymo prietaisai negalima valdyti diagnostiniu būdu. Todėl ji būtų galima įtraukti į diagnostinės sistemos protokolą kartu su priekabos valdymo prietaisu.</p>
<p><b>(LV)</b></p>	<p><b>Norādījums:</b> Pēc elektriskā iebūvējamā bloka iemontēšanas jāieprogrammē funkciju paplašinājums atbilstoši automobiļa ekspluatācijai ar piekabi saskaņā ar automobiļu ražotāja diagnostikas norādījumu. Nepieciešamības gadījumā citas automobiļa sistēmas (piem., parkošanās sistēma) jāiekodē atsevišķi atbilstoši „Automobiļa ekspluatācijai ar piekabi”. Piekabes vadības ierīci nav iespējams veikt diagnostiku, līdz ar to diagnostikas protokolā var parādīties ieraksti saistībā ar piekabes vadības ierīci.</p>
<p><b>(EST)</b></p>	<p><b>Juhis:</b> Pärast elektrilise mooduli paigaldamist tuleb funktsioonide laiendamise haagisega kasutamise jaoks programmeerida vastavalt sõiduki tootja diagnostikajuhistele. Vastasel korral on vajalik sõiduki muud süsteemid (näiteks abistamine parkimisel) kodeerida eraldi vastavalt seadmetega varustatuse variandile „Kasutamine haagisega“ Haagise juhtseade ei ole võimeline diagnostika tegemmiseks, seetõttu võib seoses haagise juhtseadmega esineda kirjeid diagnostikaprotokollis</p>
<p><b>(SLO)</b></p>	<p><b>Navodilo:</b> Po vgradnji elektromontažnega seta, razširitev funkcije, ki obsega tudi delovanje prikolice, mora biti programirana v skladu z navodili za diagnostiko proizvajalca avtomobila. Morebiti še drugi sistemi avtomobila (npr. pomoč pri parkiranju) morajo biti kodirani posebej na različico opreme "delovanje prikolice". Naprava za krmiljenje prikolice ne more biti diagnosticirana, zaradi katerega lahko pride do vpisov v protokol za diagnostiko, v zvezi z napravo za krmiljenje prikolice.</p>
<p><b>(SK)</b></p>	<p><b>Pokyn:</b> Po vstavaní elektrickej sady pre vmontovanie, musí byť naprogramované rozšírenie funkcií pre prevádzku s prívesom, podľa diagnostického pokynu výrobcu vozidla. Prípadne sa musia ďalšie systémy vozidla (napr. pomocné zariadenie pre zaparkovanie) zvlášť zakódovať do variantu vybavenia „Prevádzka s prívesom“. Riadiace zariadenie prívesu nie je schopné diagnózy, týmto potom môže dôjsť k záznamom v diagnostickom protokole, v spojení s riadiacim prístrojom prívesu.</p>

KIT

736941

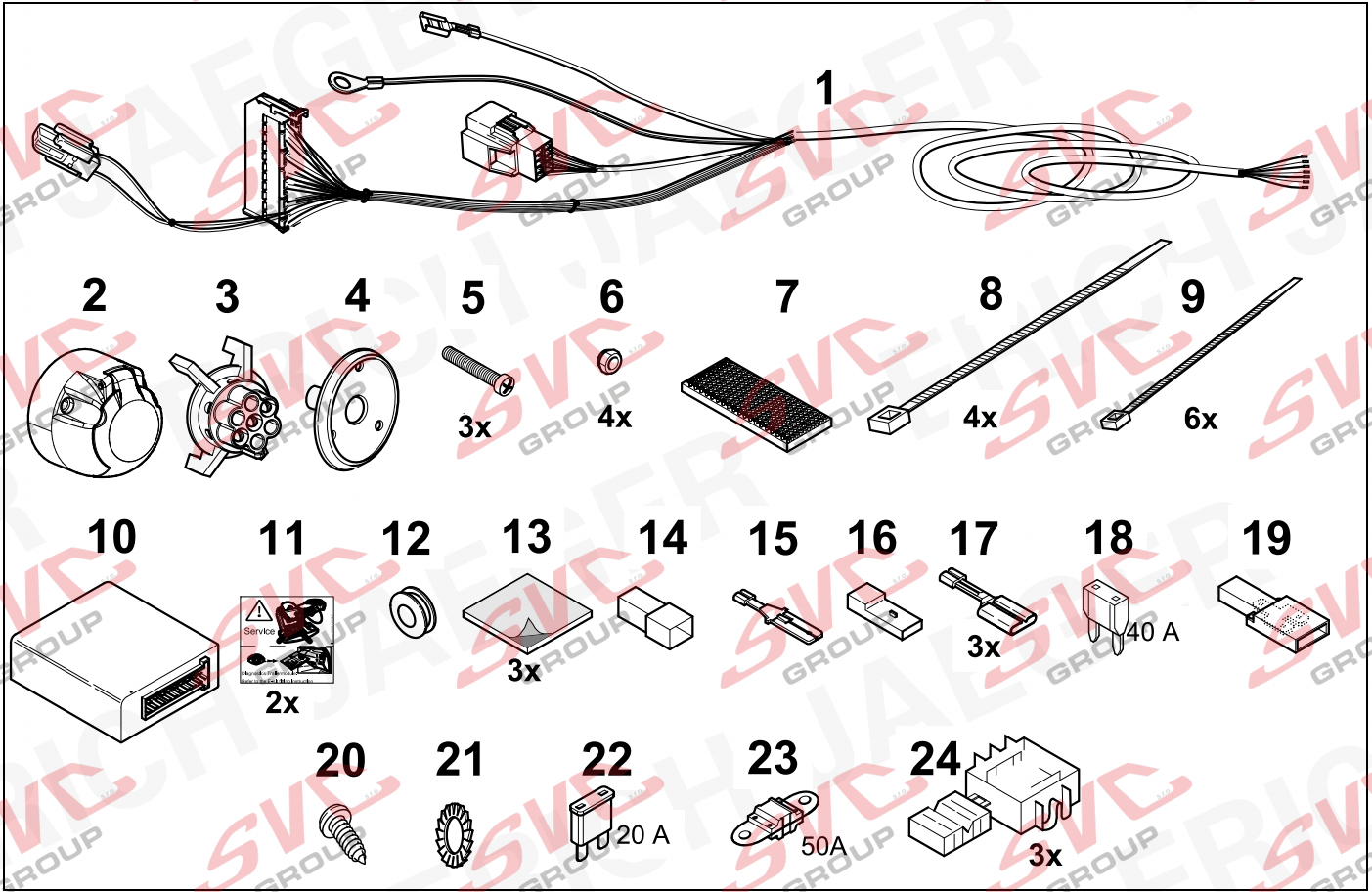

KIT

748841

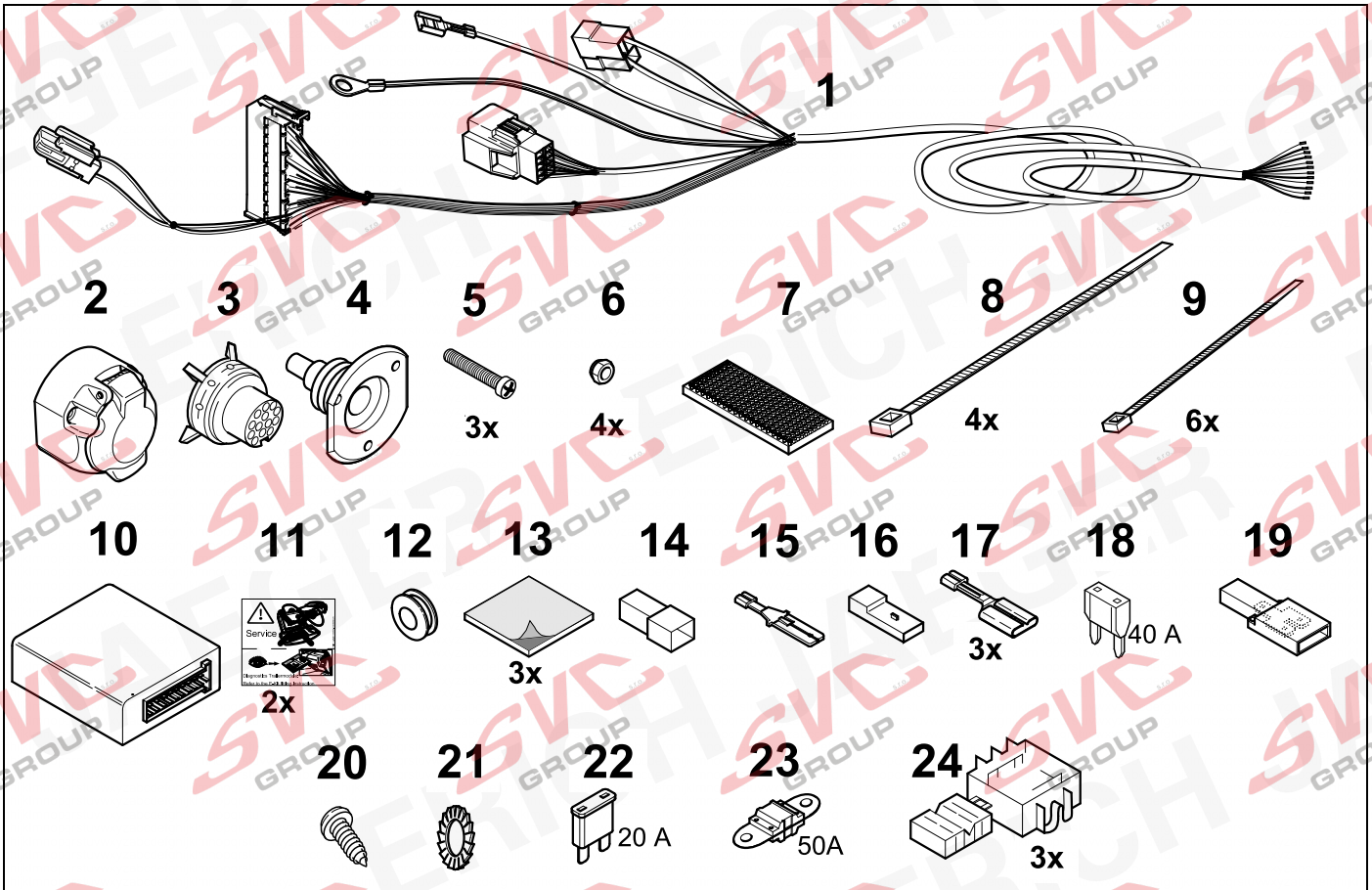



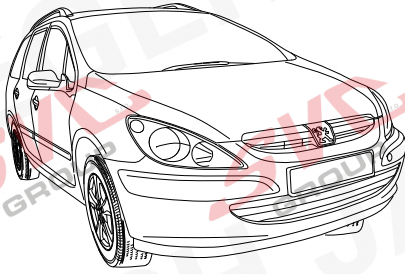

Peugeot 307 05/05 >>  
 Peugeot 307 Break 05/05 >>  
 Peugeot 307 SW 05/05 >>  
 Peugeot 307 CC 05/05 >>



3

-

19

+

74

-

86

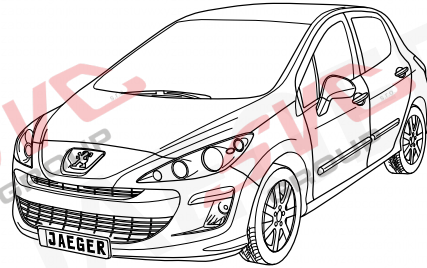

Peugeot 308 09/07 >> 10/08  
 Peugeot 308 SW 05/08 >> 10/08



20

-

41

+

74

-

86

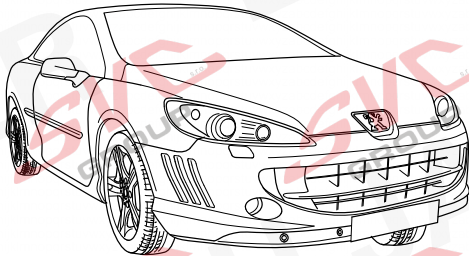

Peugeot 407 05/04 >>  
 Peugeot 407 SW 05/04 >>  
 Peugeot 407 Coupé 10/05 >>



42

-

63

+

74

-

86

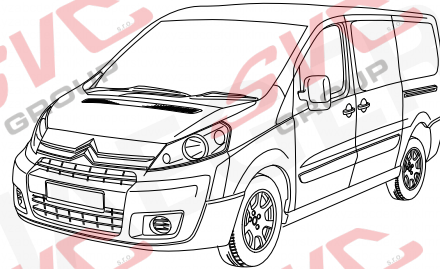

Peugeot Expert 01/07 >>  
 Citroen Jumpy 01/07 >>  
 Fiat Scudo 01/07 >>



64

-

86



3

307

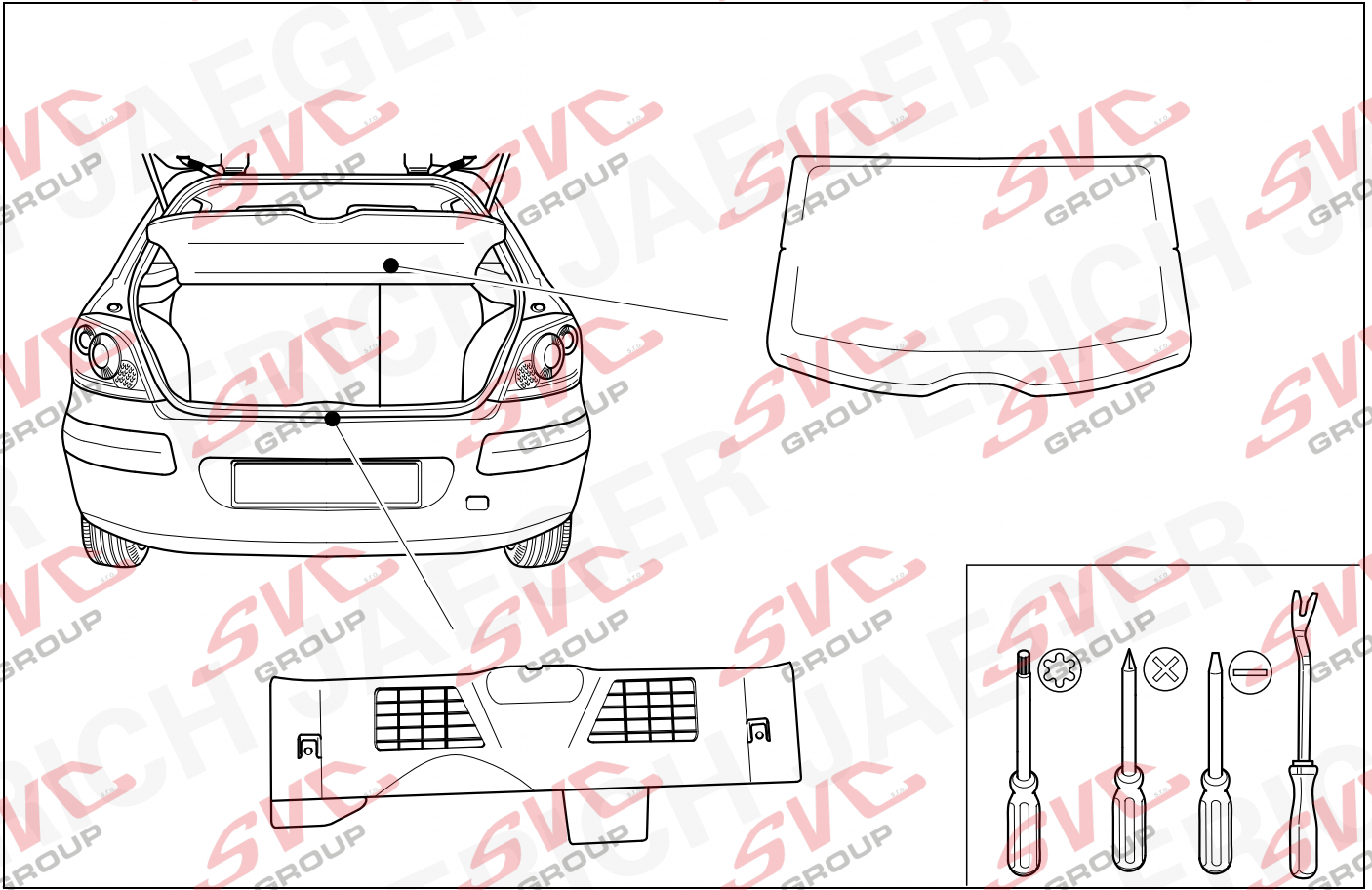

4

307 CC

307 Break

307 SW

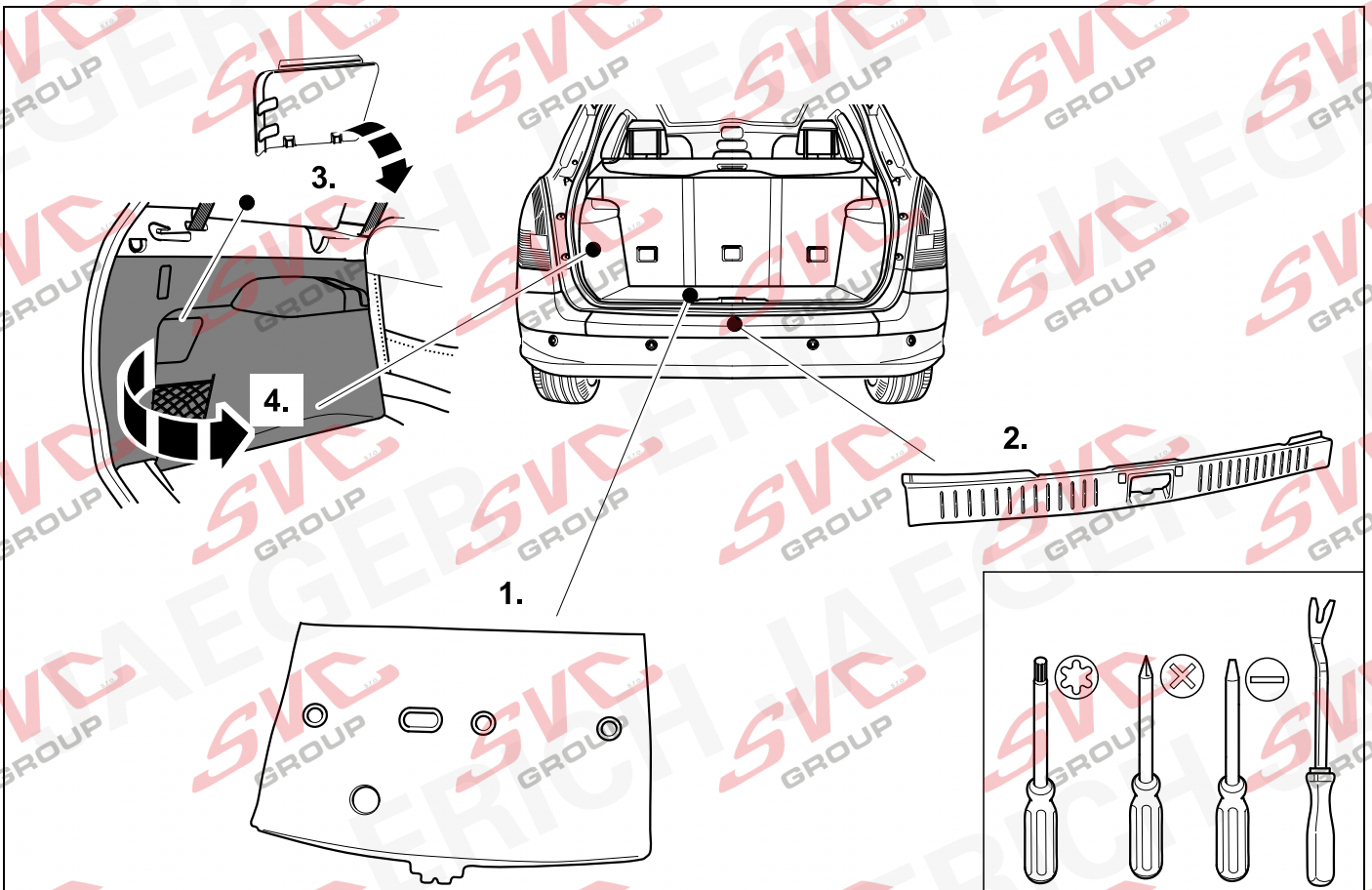

5

307

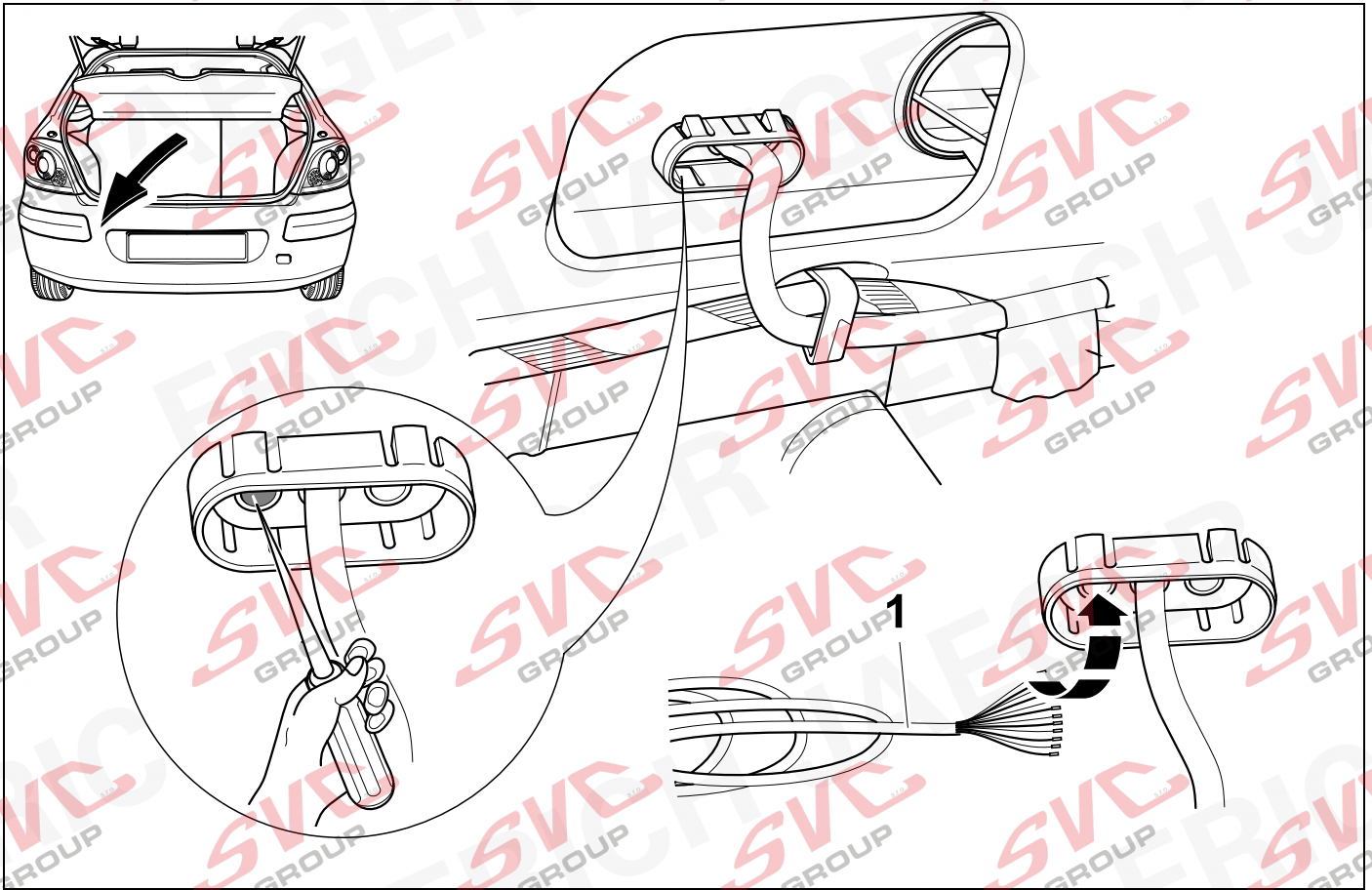

6

307 CC

307 Break

307 SW

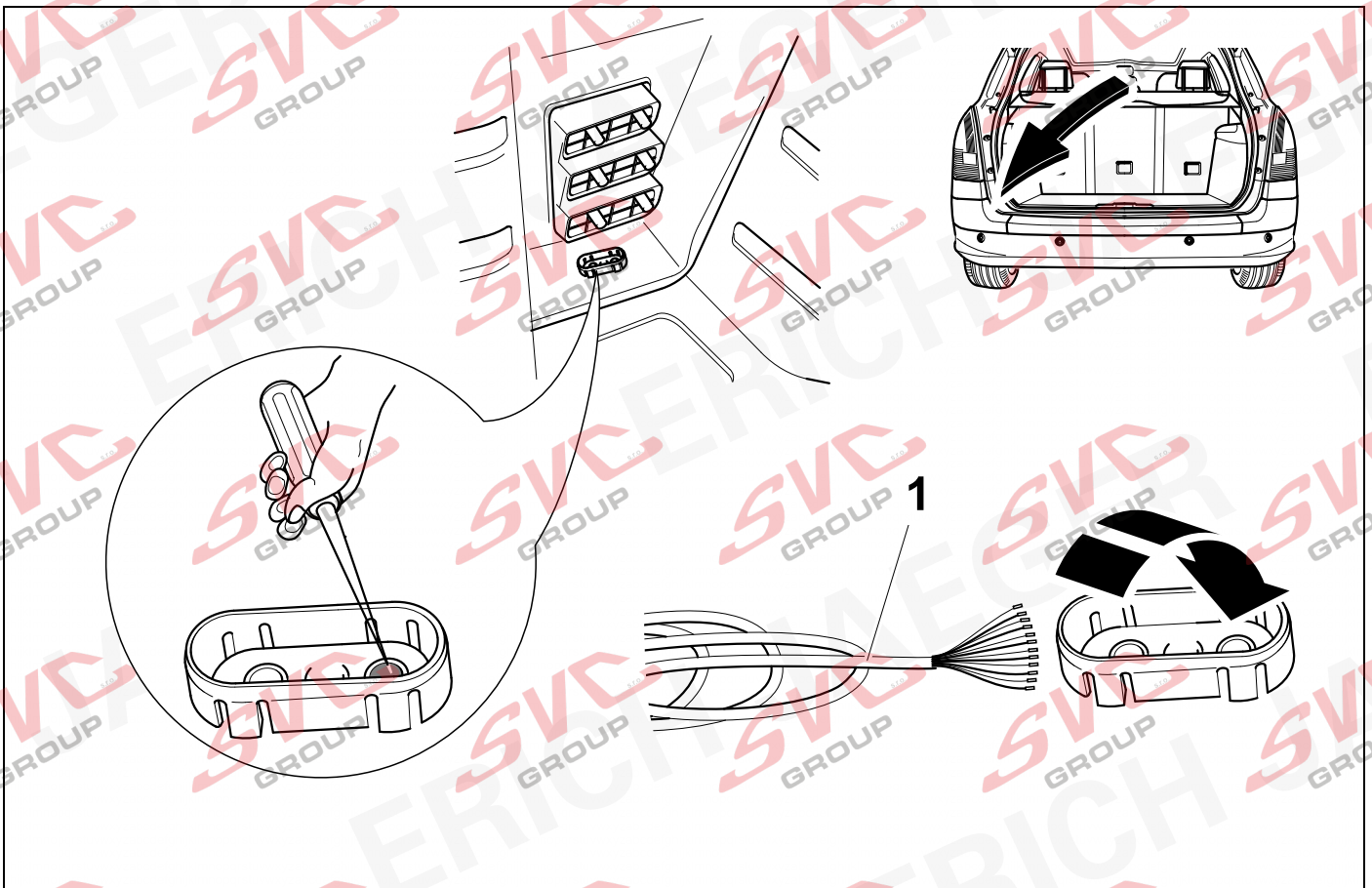

7

307

307 Break

307 SW

307 CC

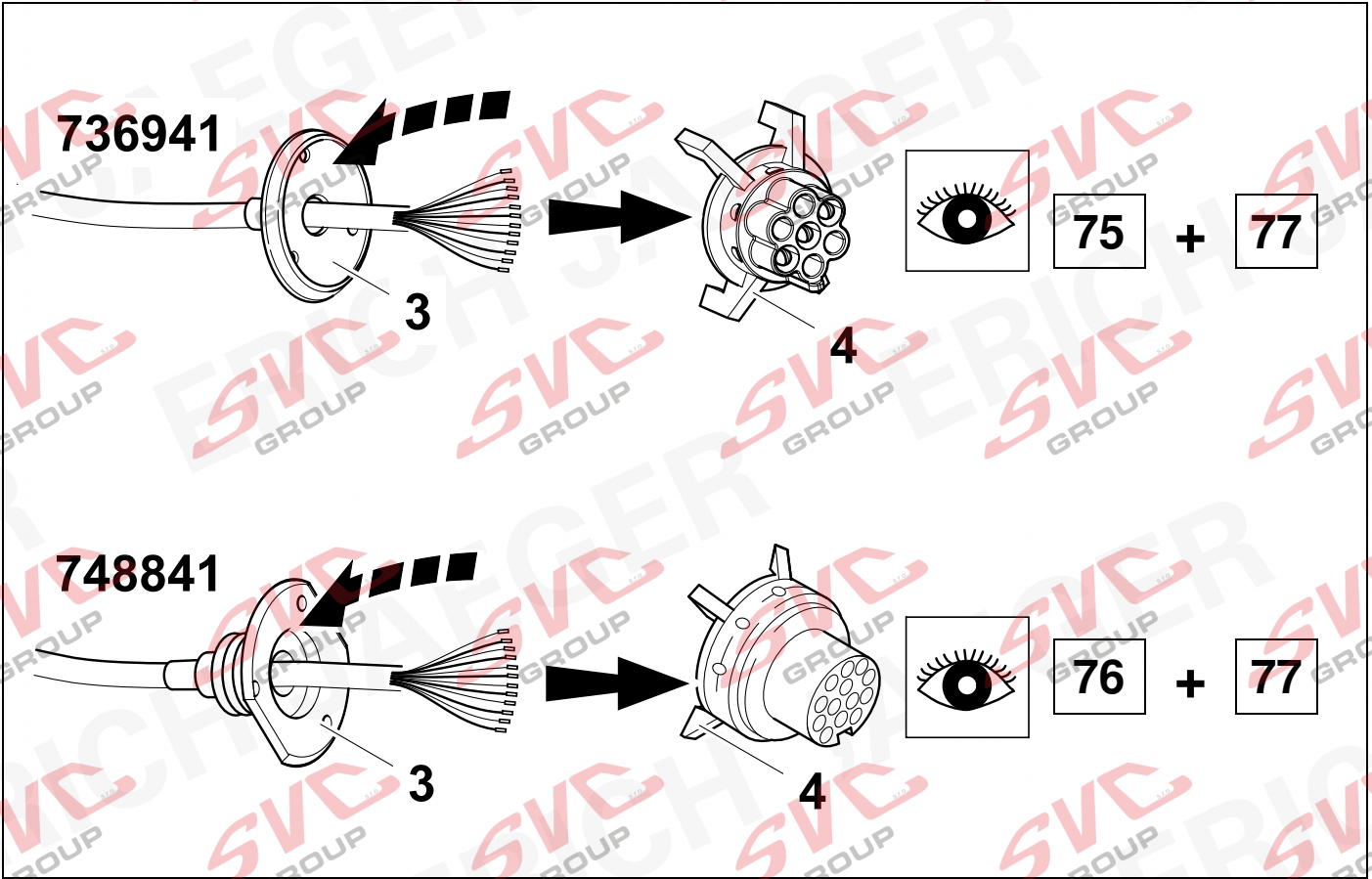

8

307



78

307 CC

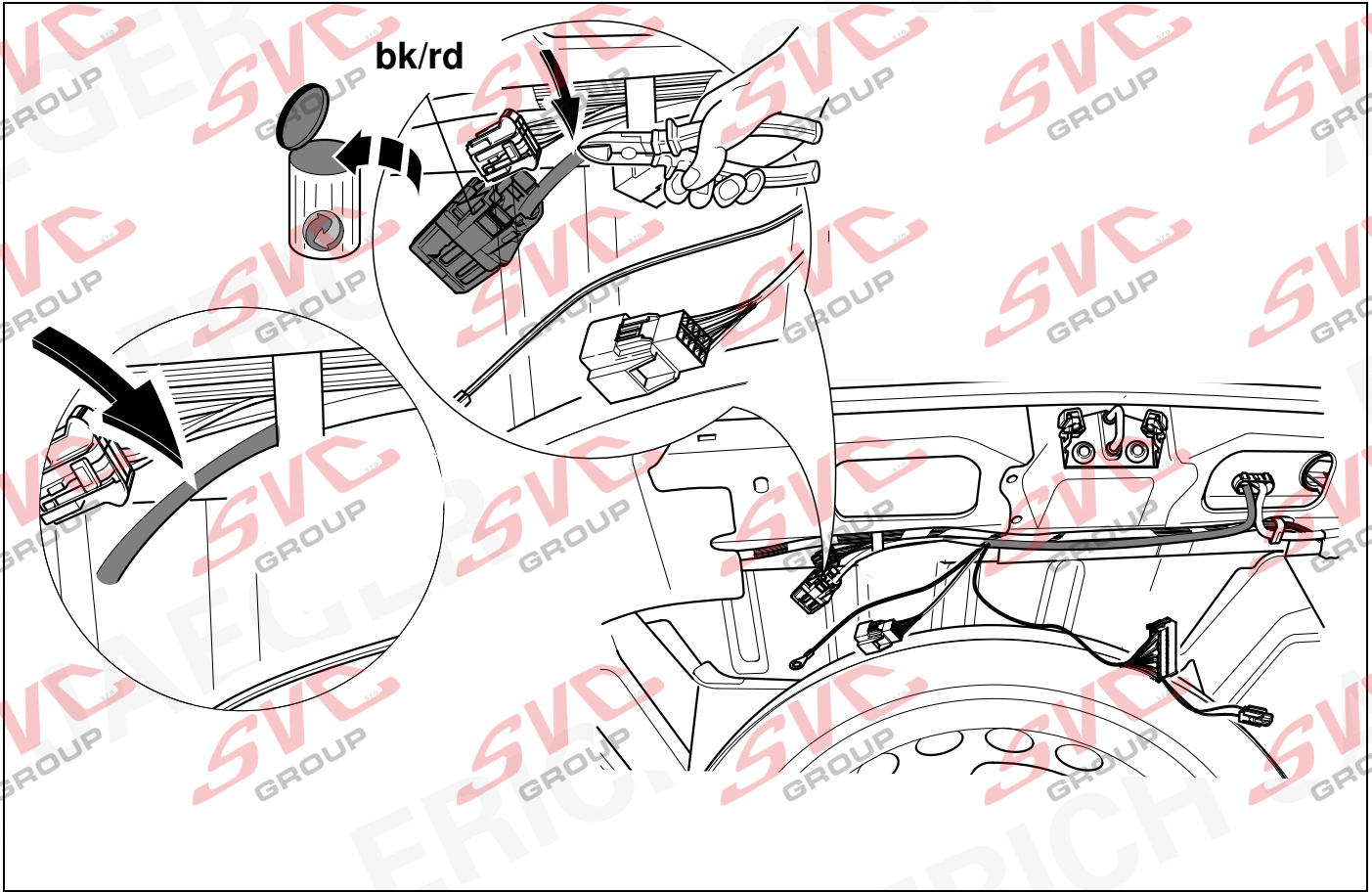

9



78

307 Break / 307 SW

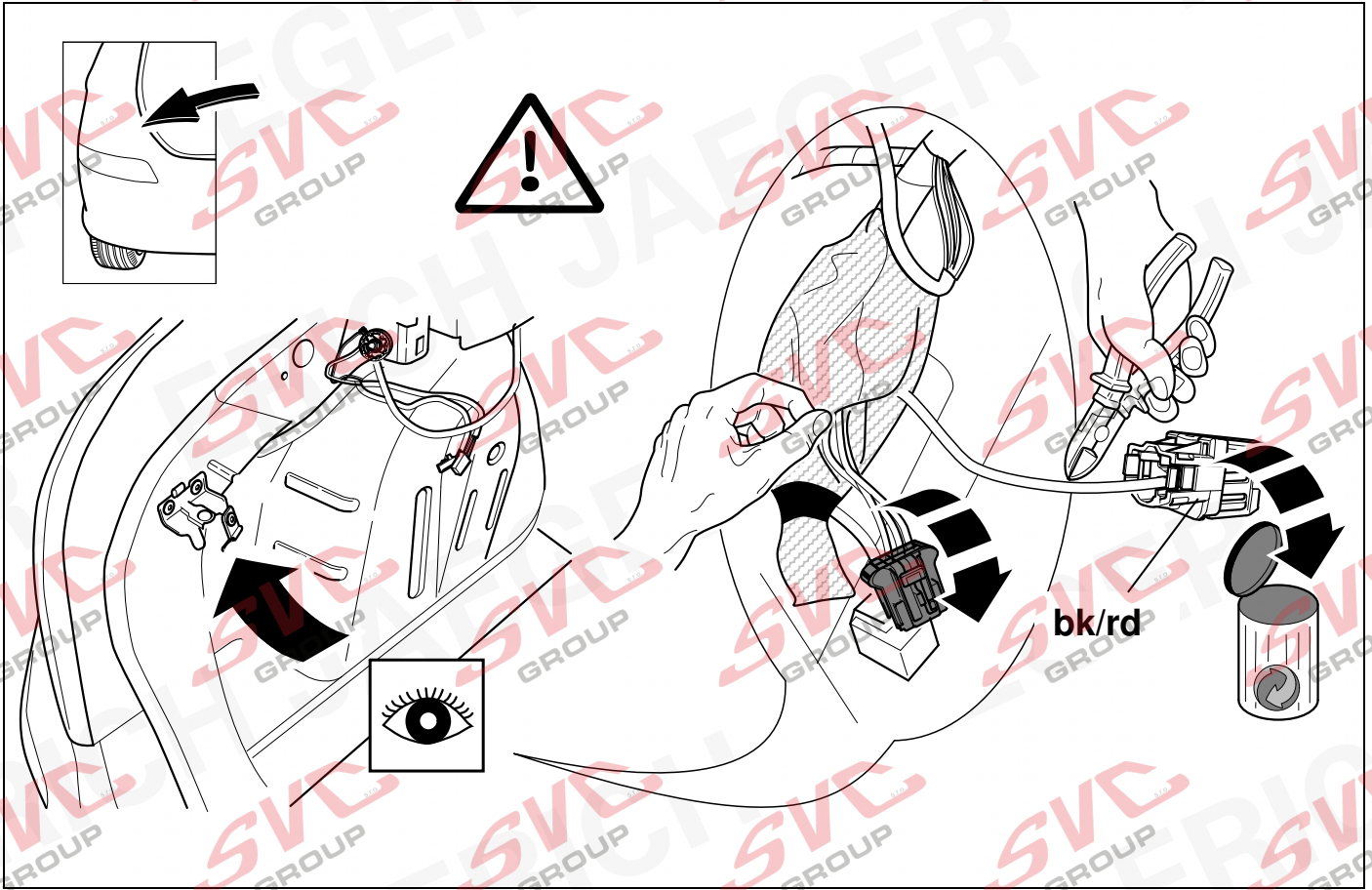

10

307 / 307 CC



78

307 Break / 307 SW

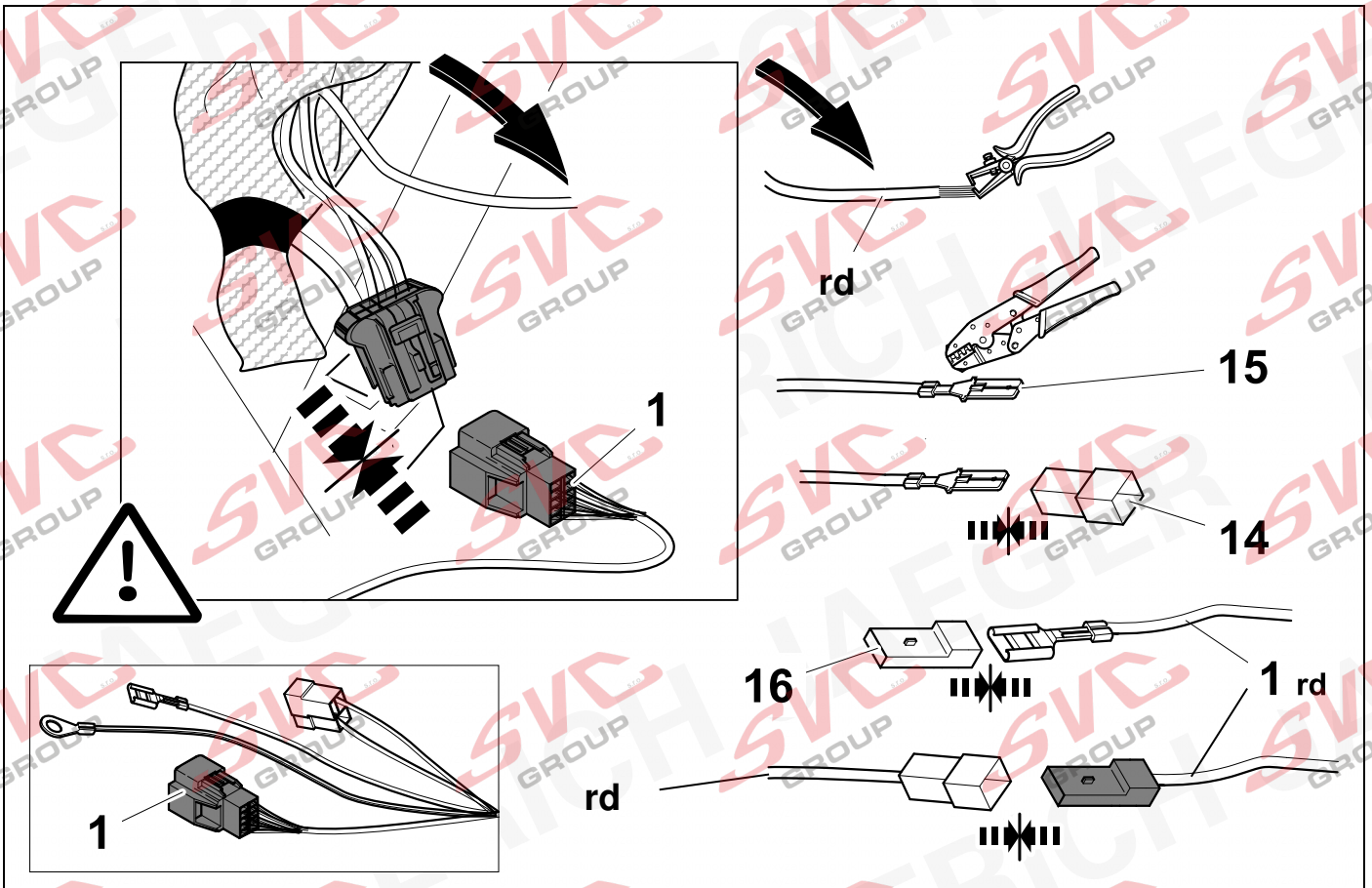

11

307

307 Break

307 SW

307 CC

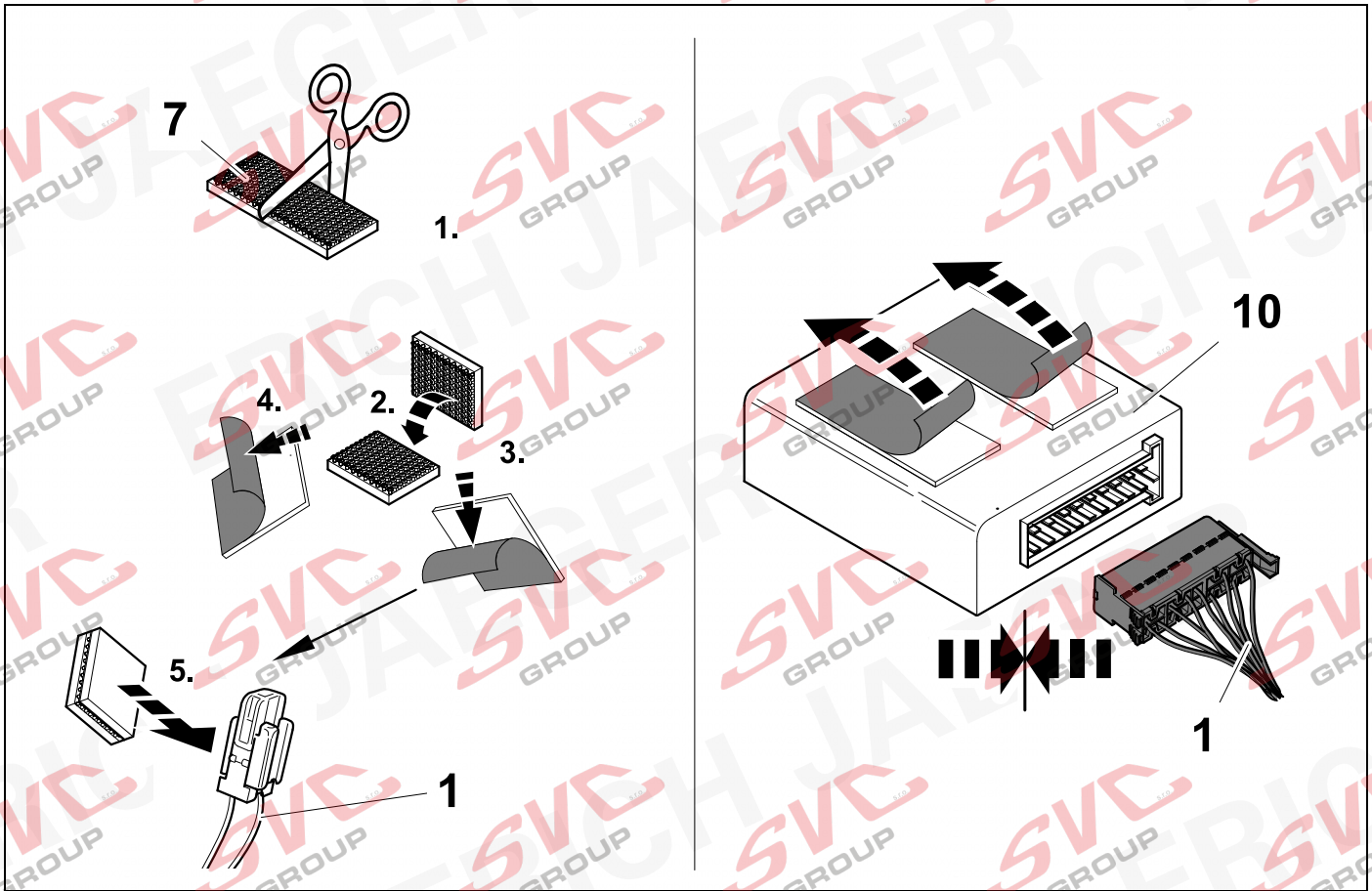

12

307

307 CC

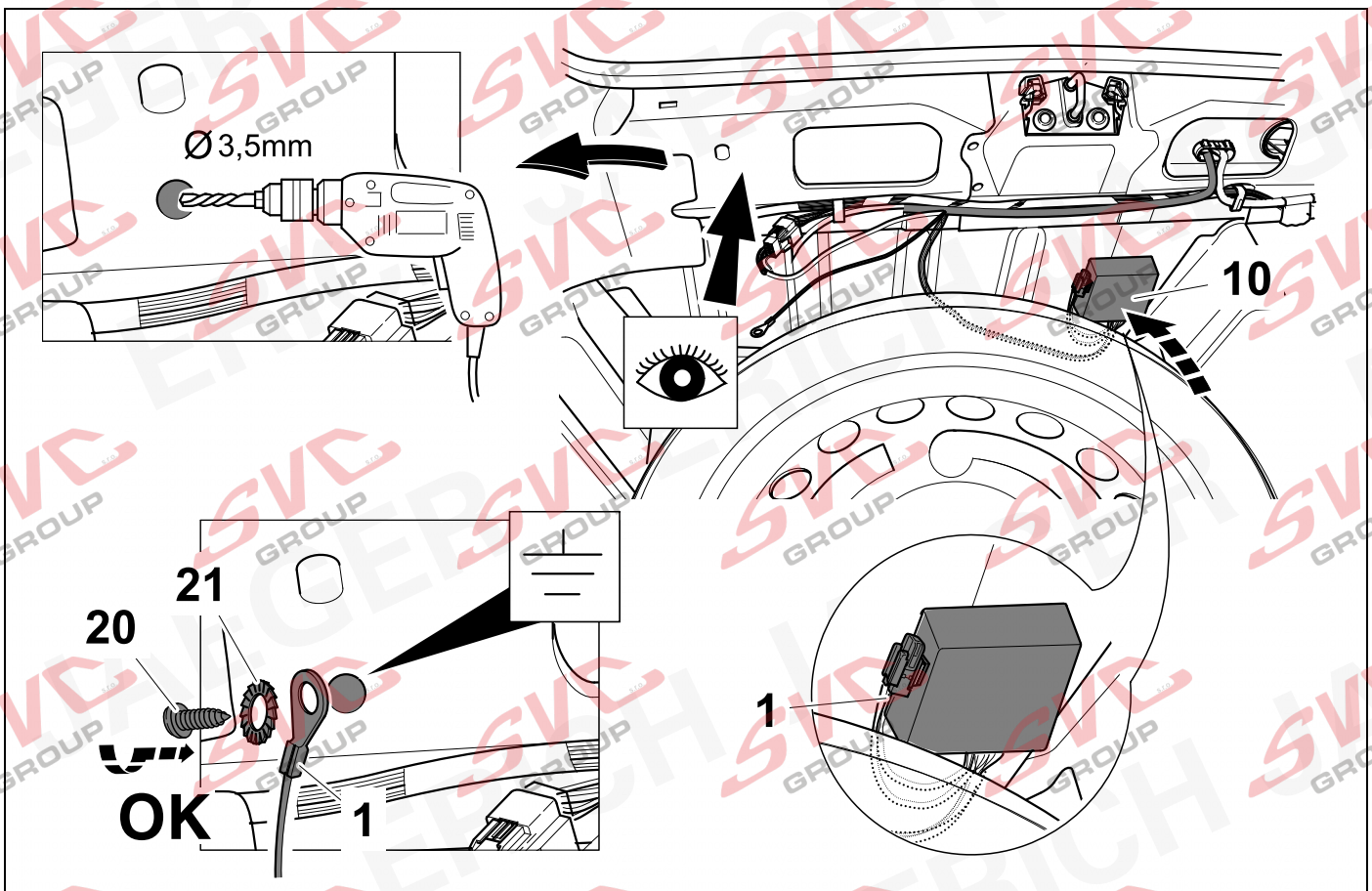

13

307 Break

307 SW

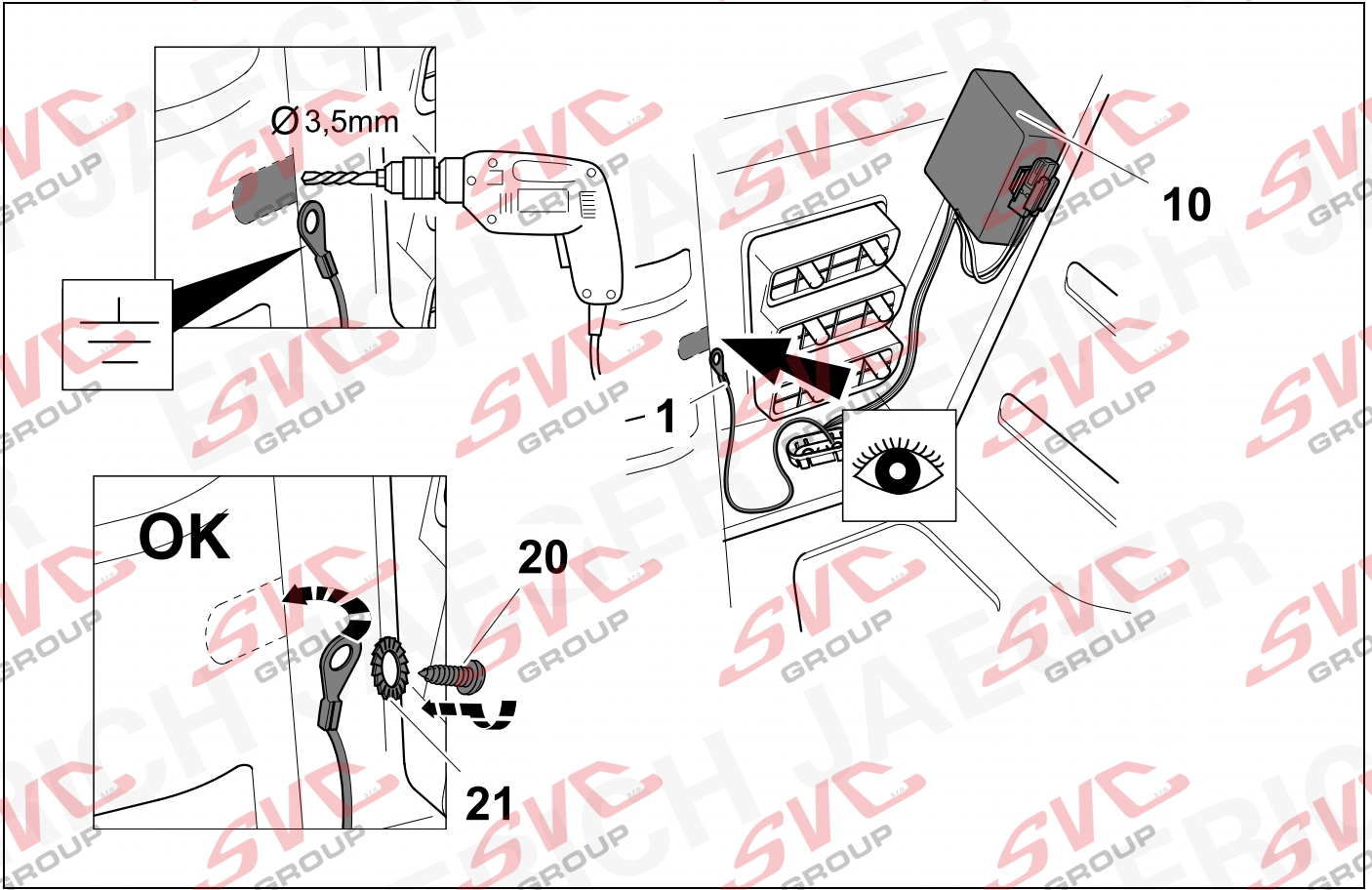

14

307

307 Break

307 SW

307 CC

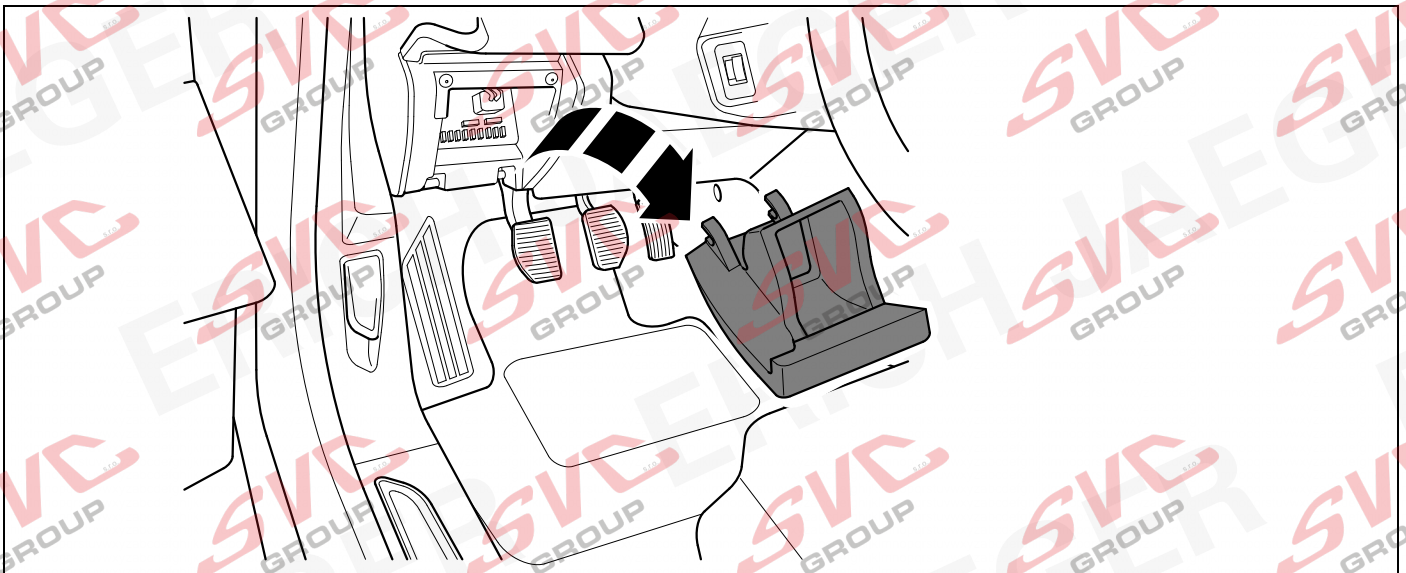

15

307

307 Break

307 SW

307 CC

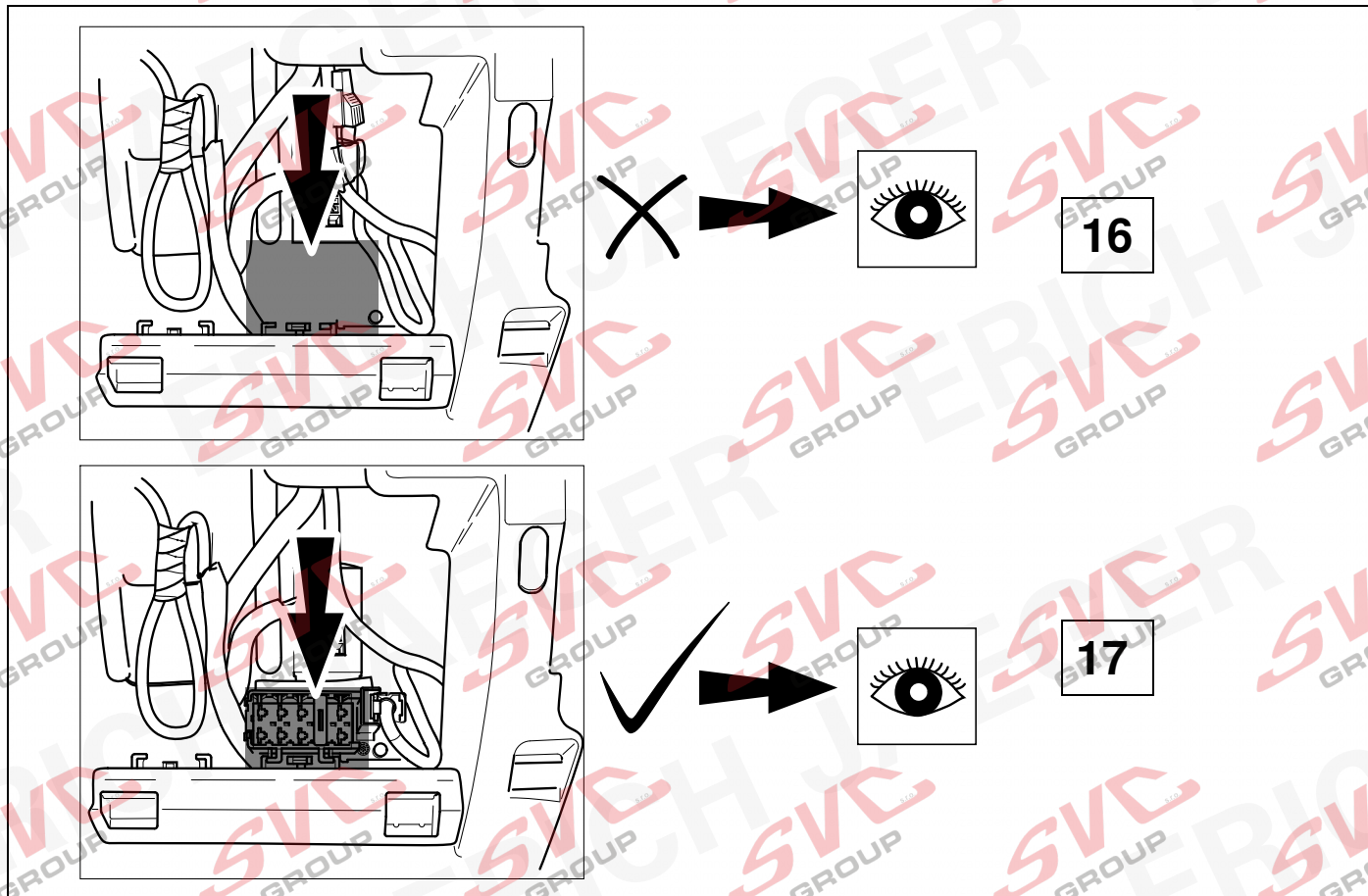

16

307 / 307 CC



78

307 Break / SW

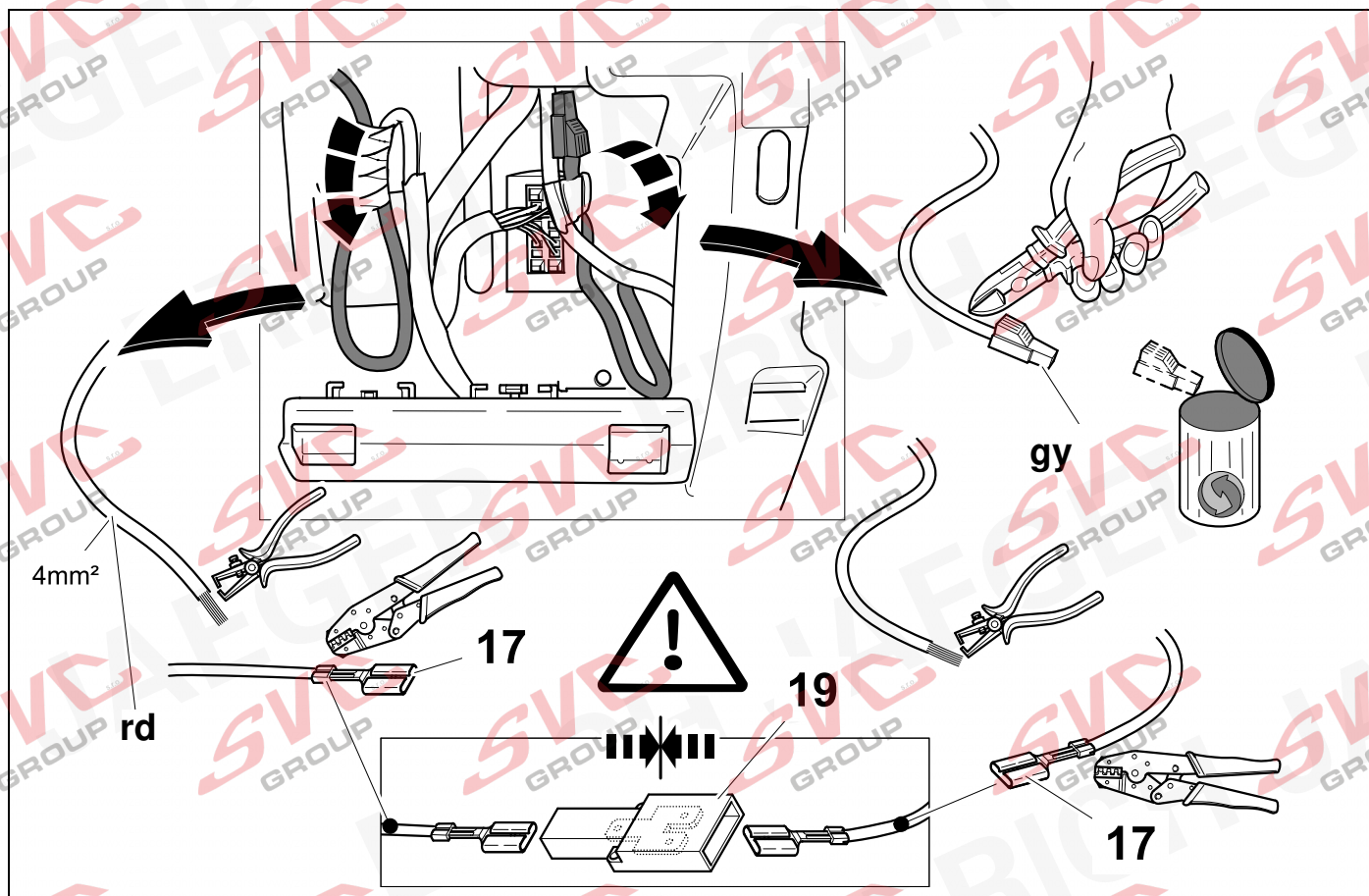

17

307 / 307 CC



78

307 Break / SW

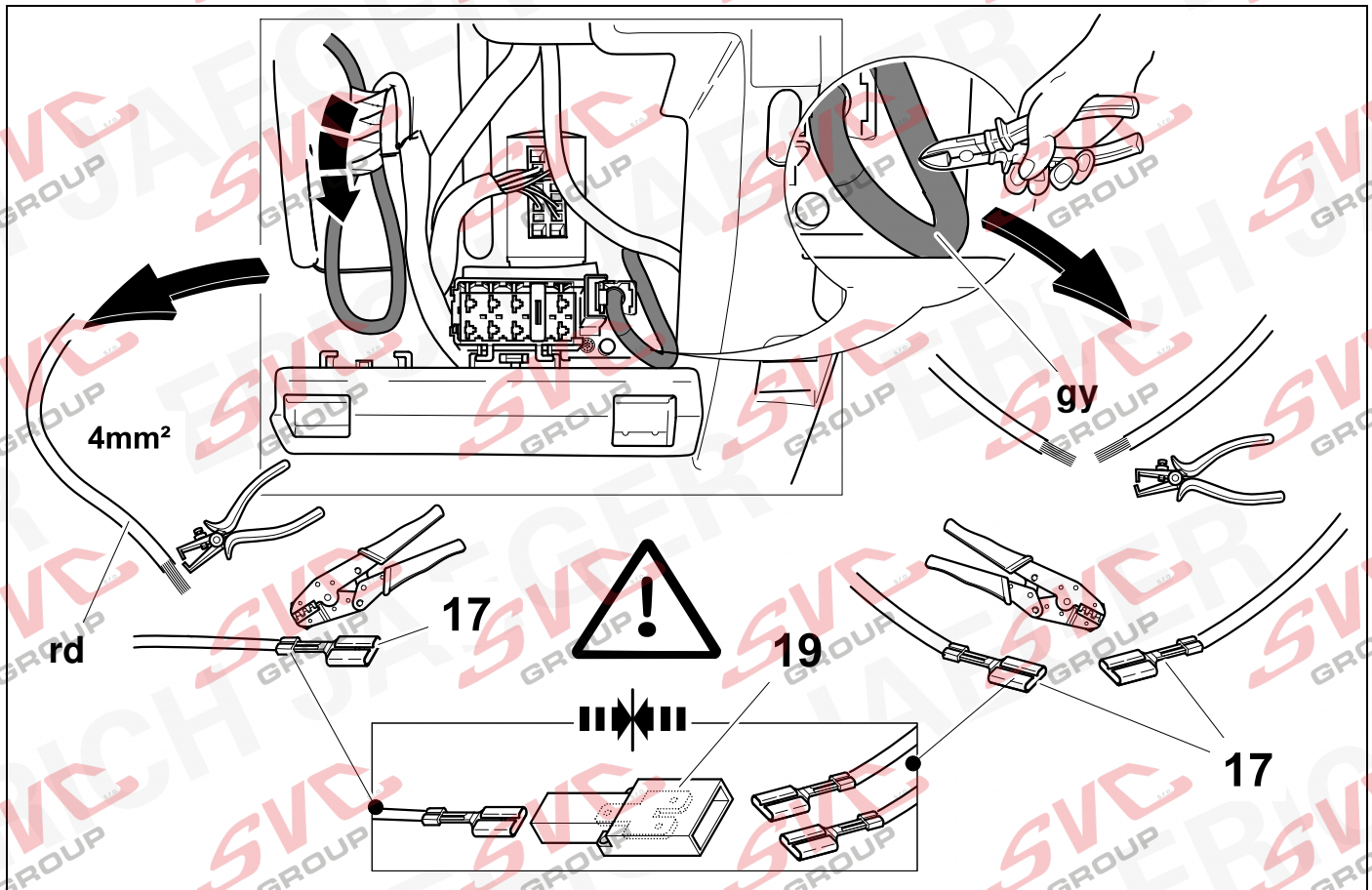

18

307

307 Break

307 SW

307 CC

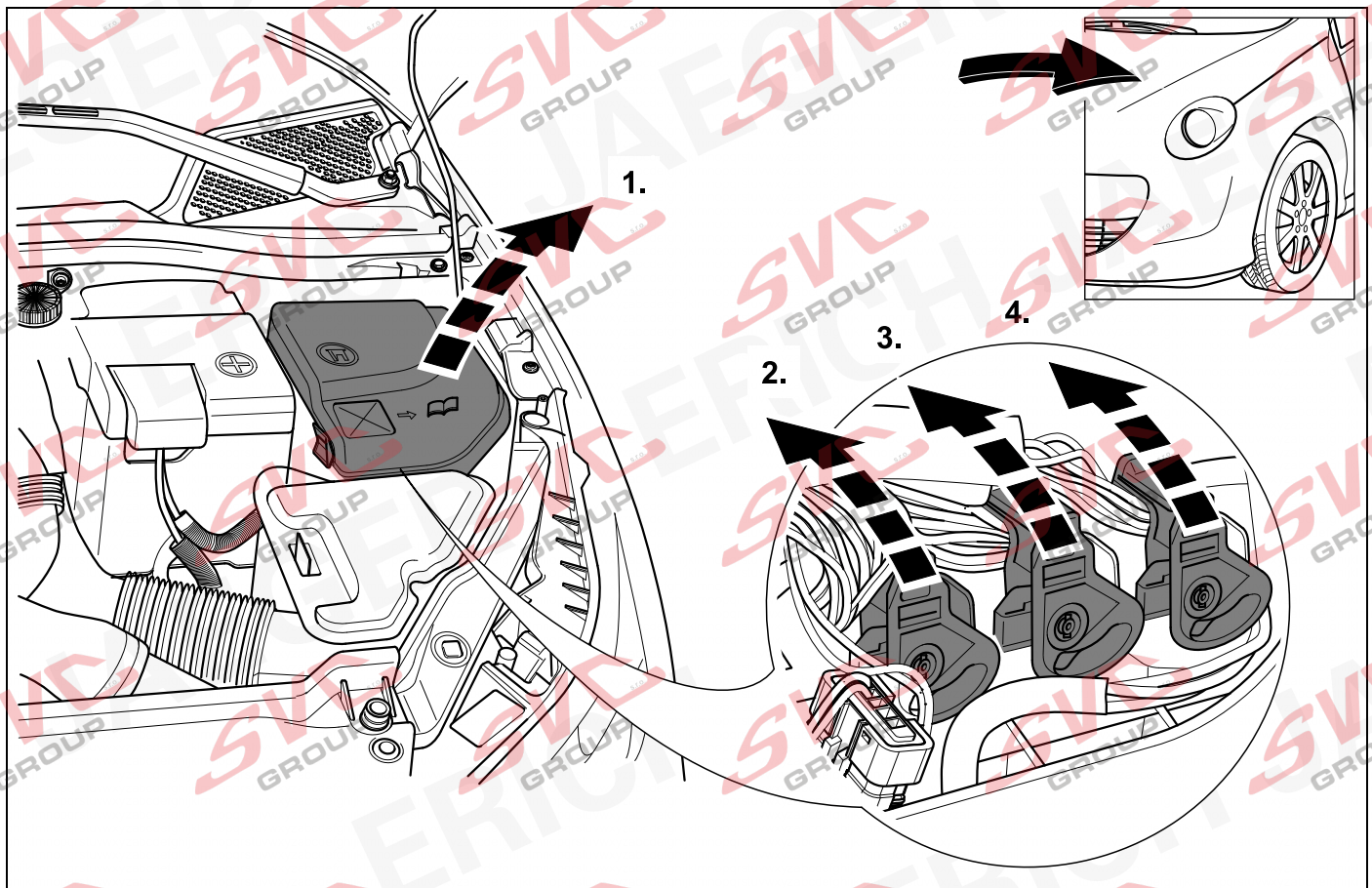



19

307

307 Break

307 SW

307 CC

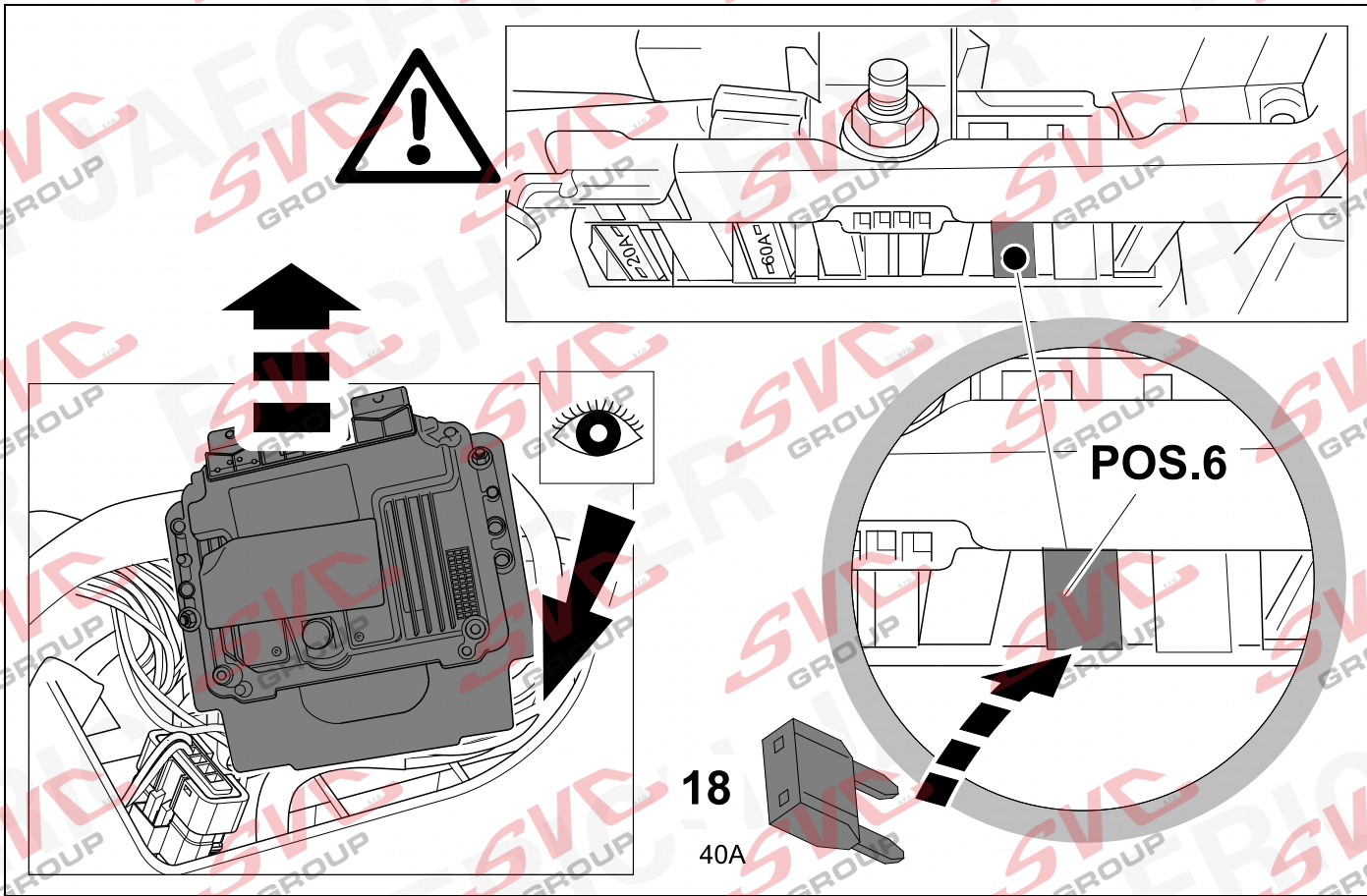

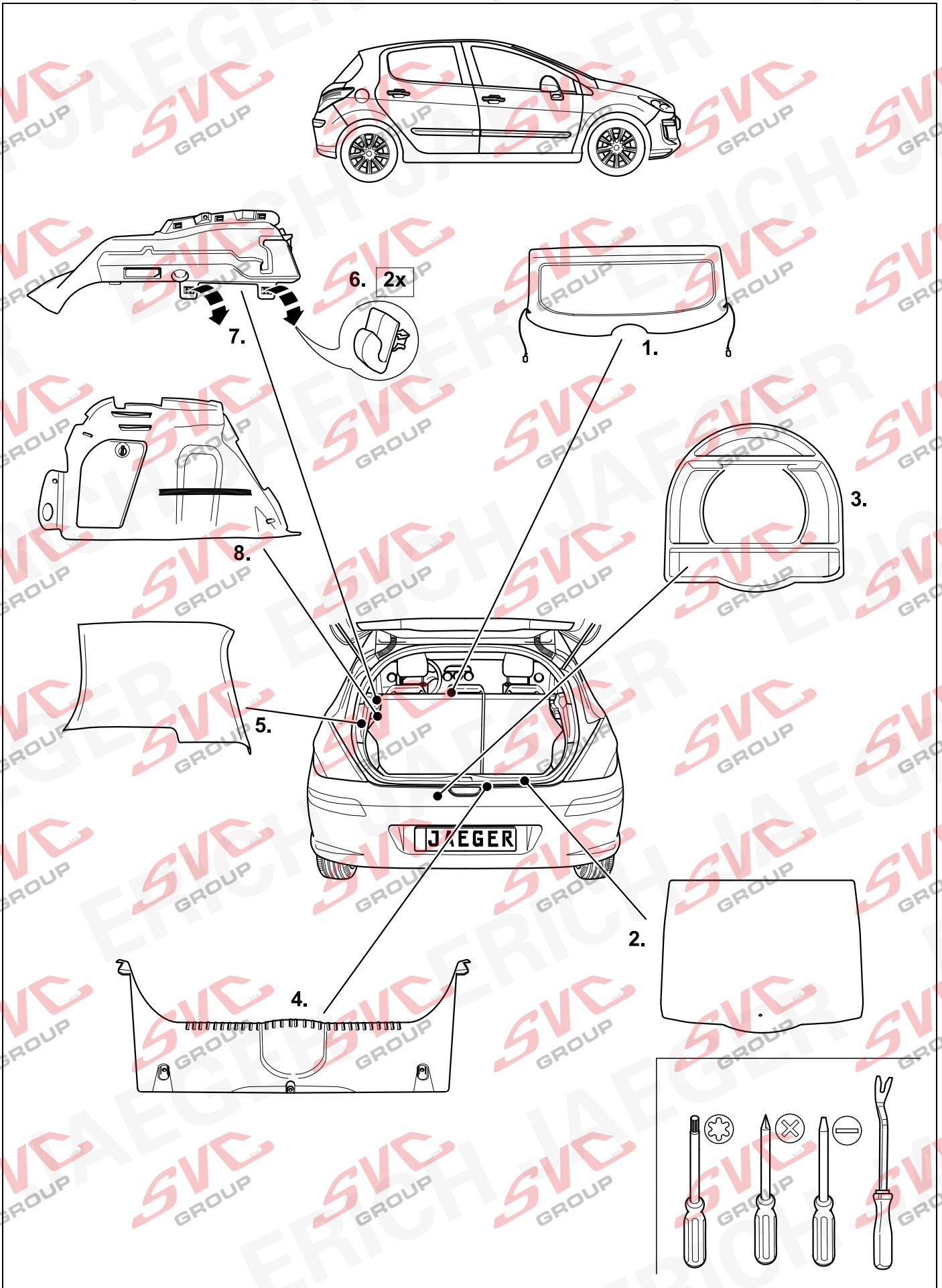

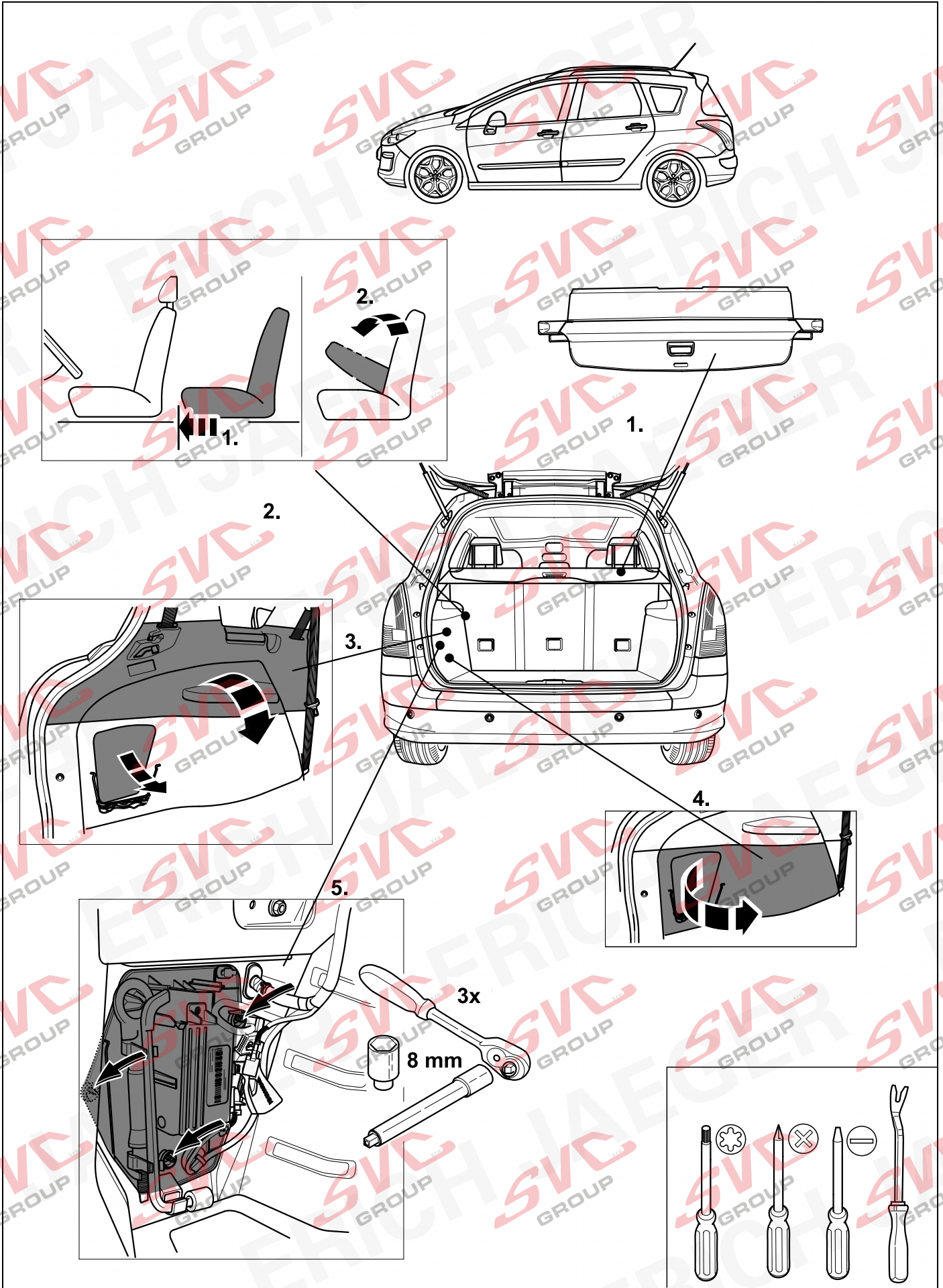

22

308

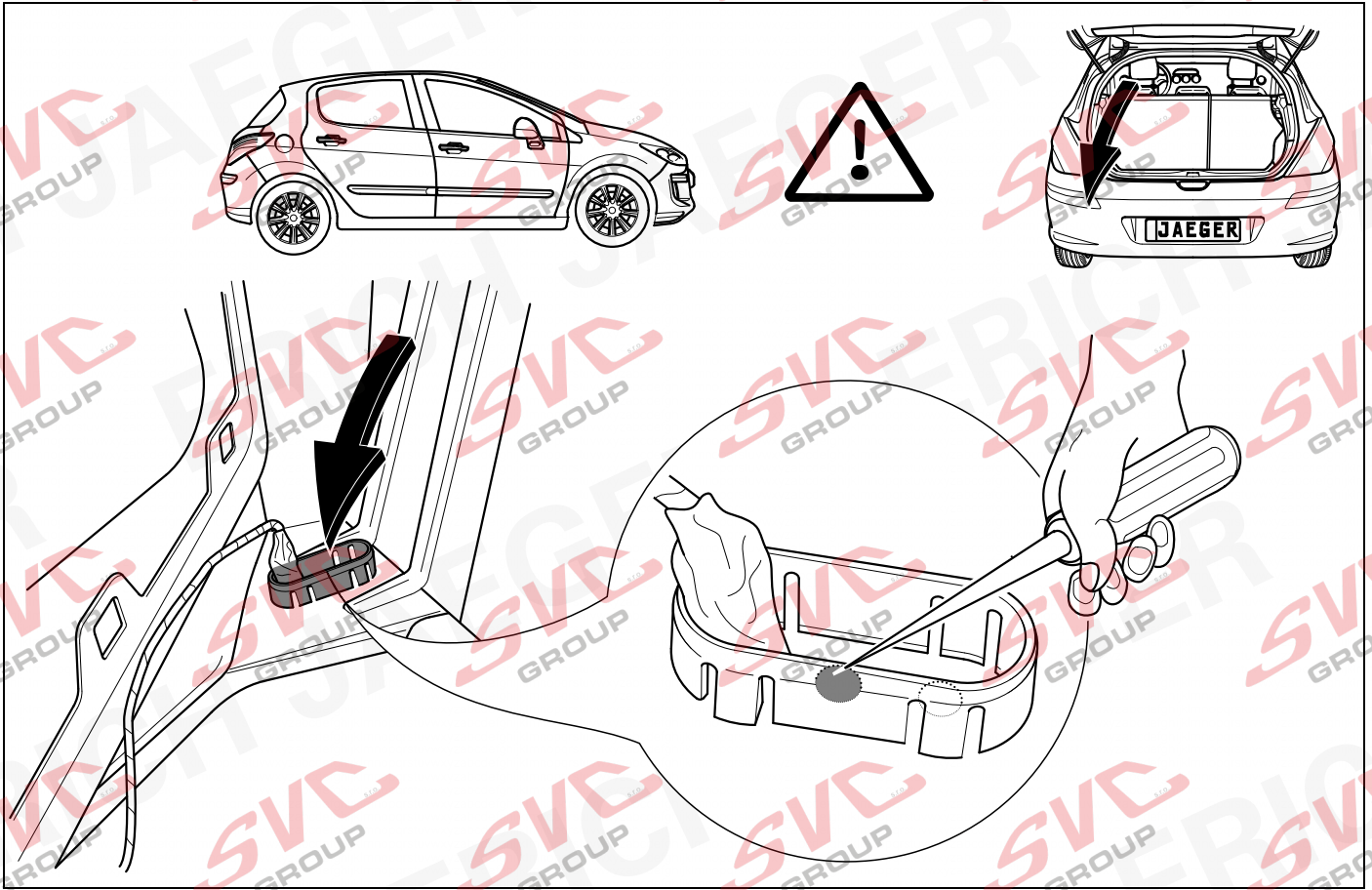

23

308

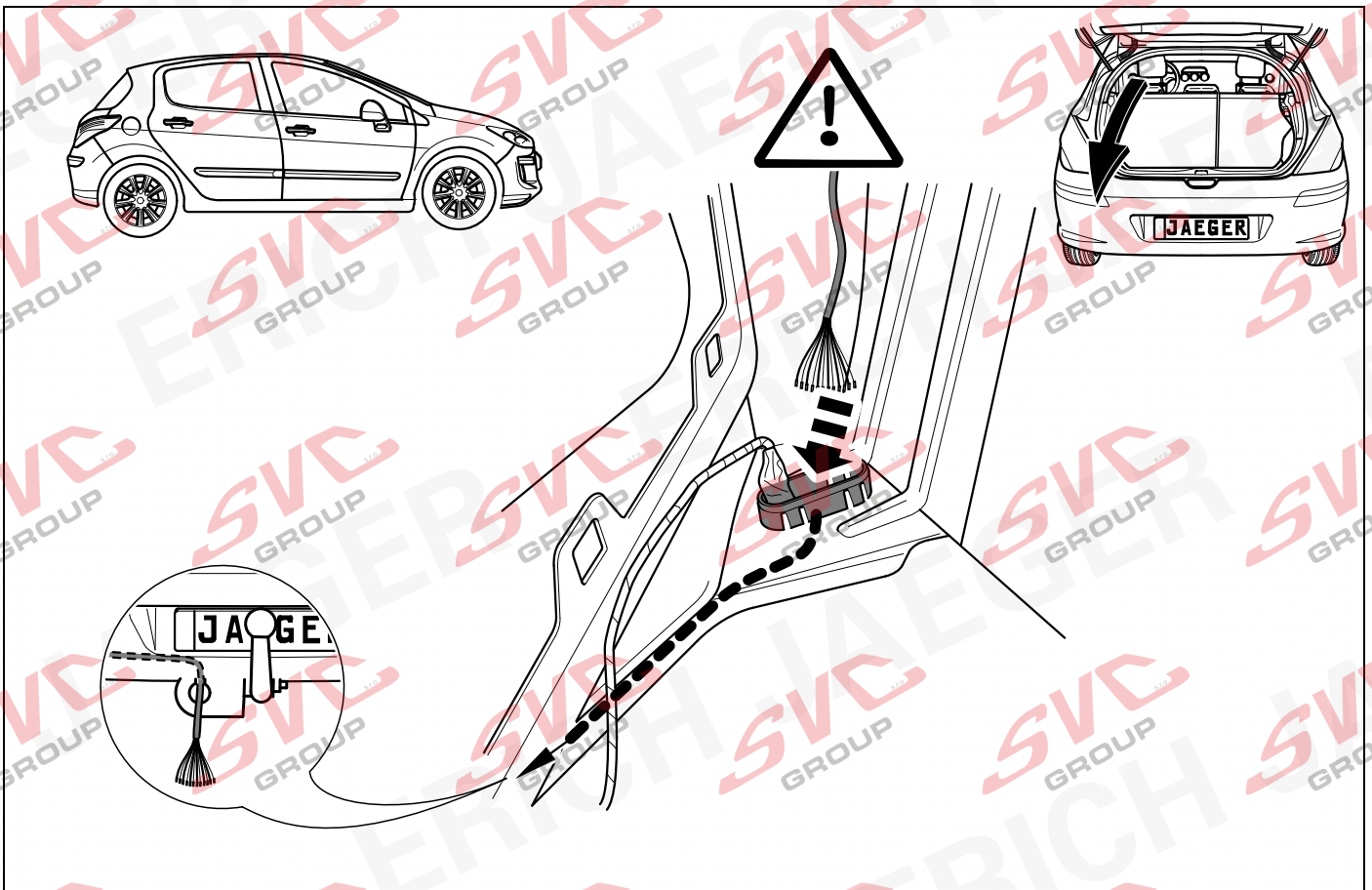

24

308 SW

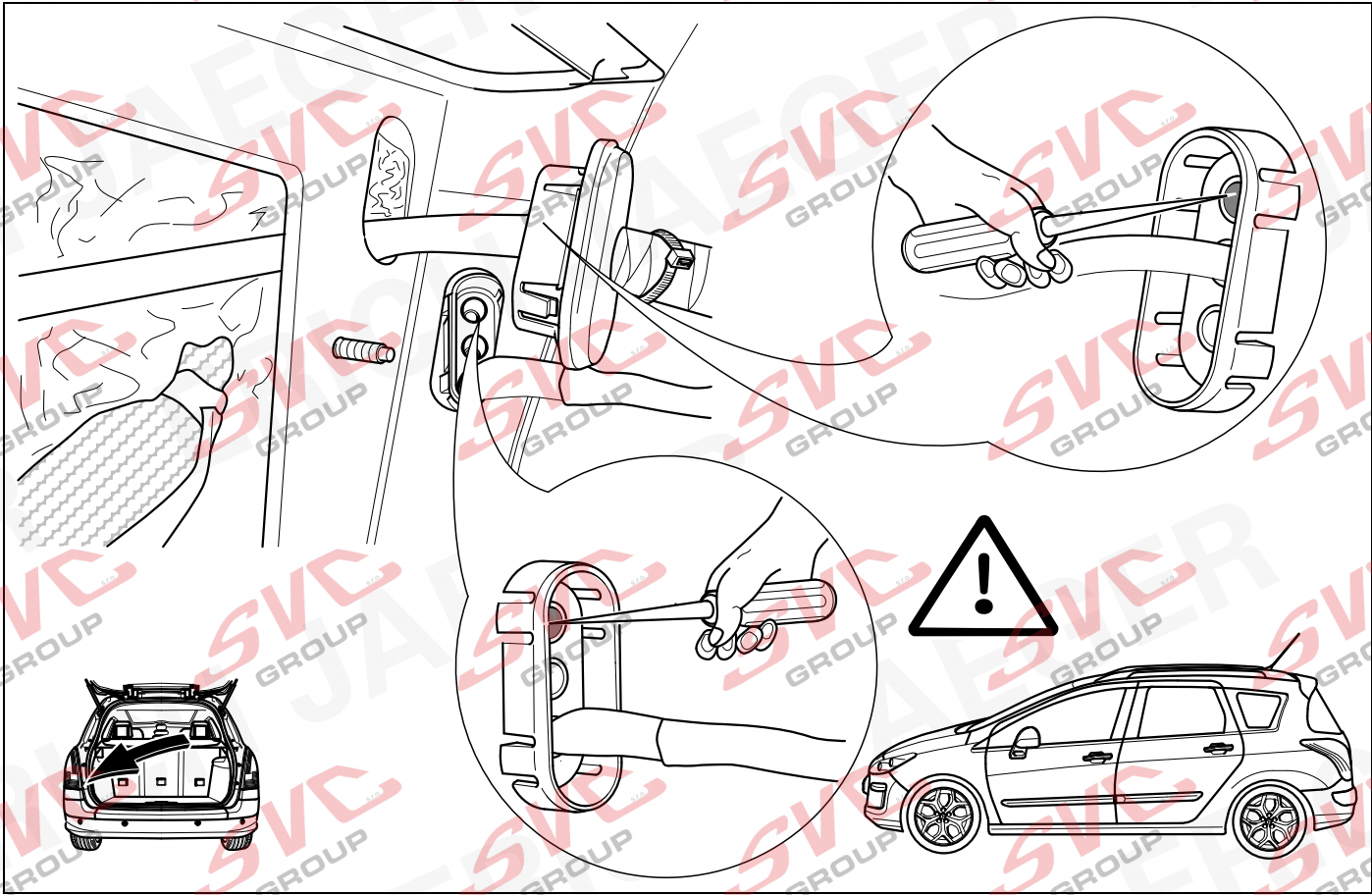

25

308 SW

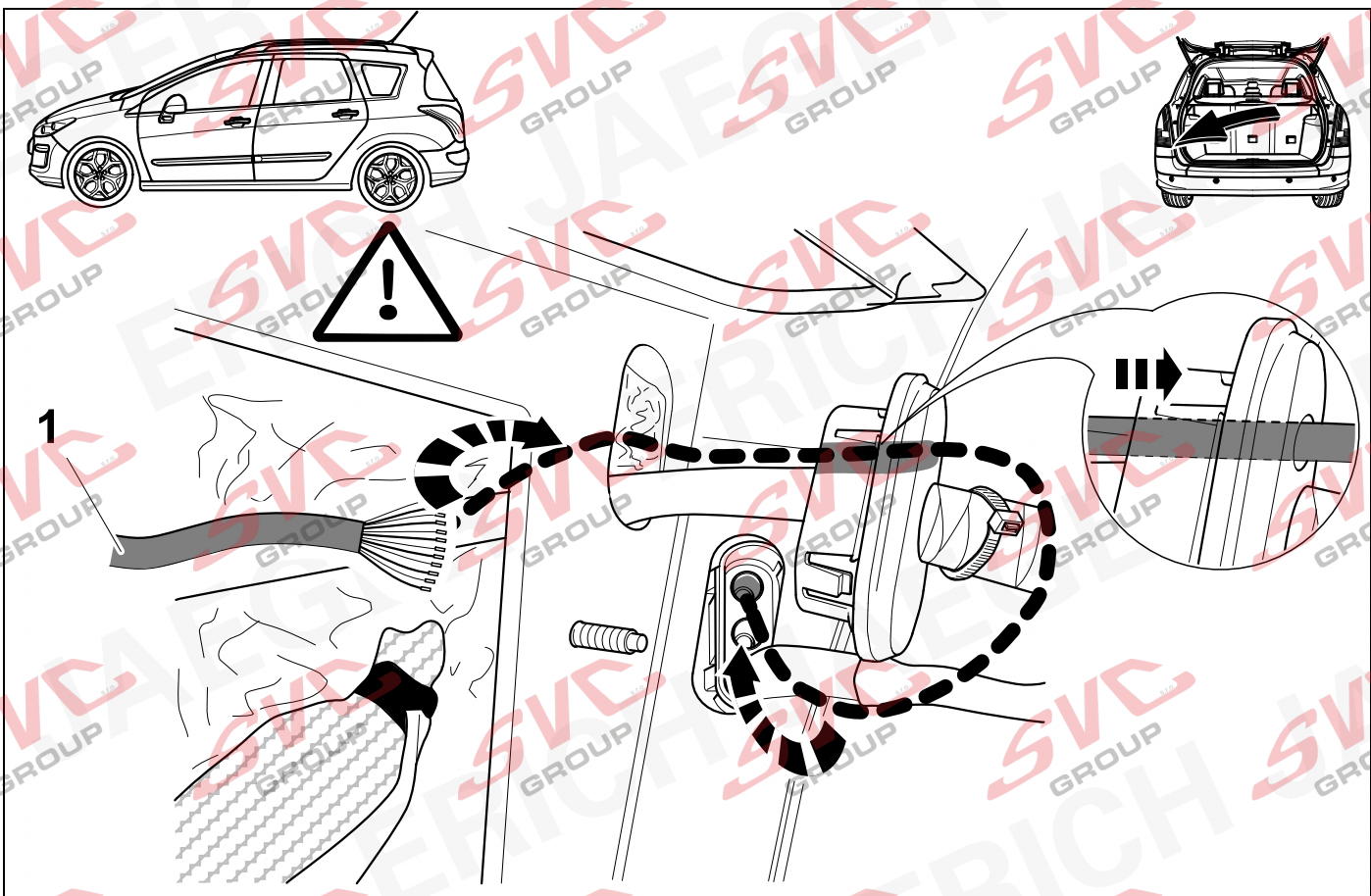

26

308

308 SW

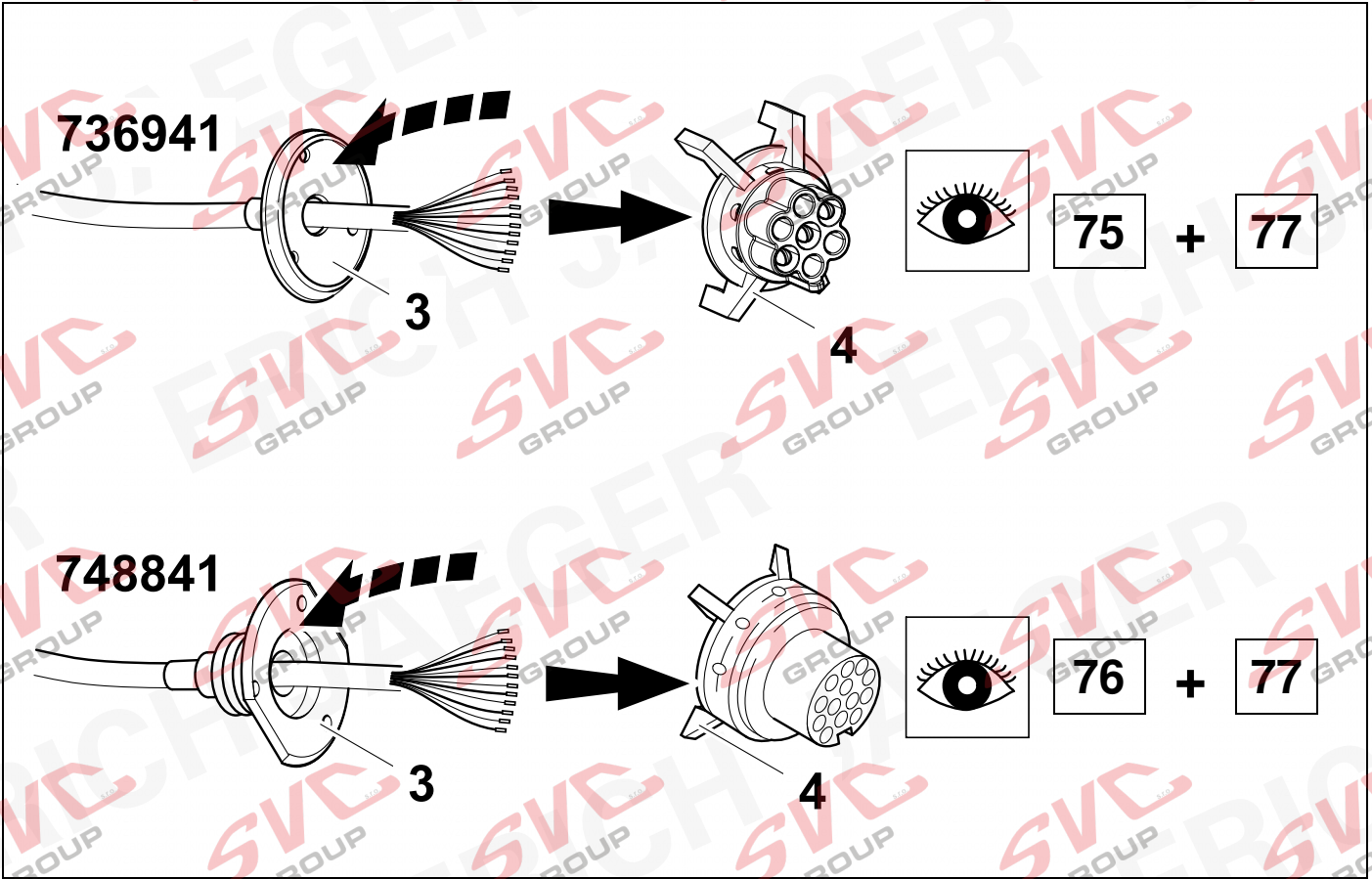

27

308



78

308 SW

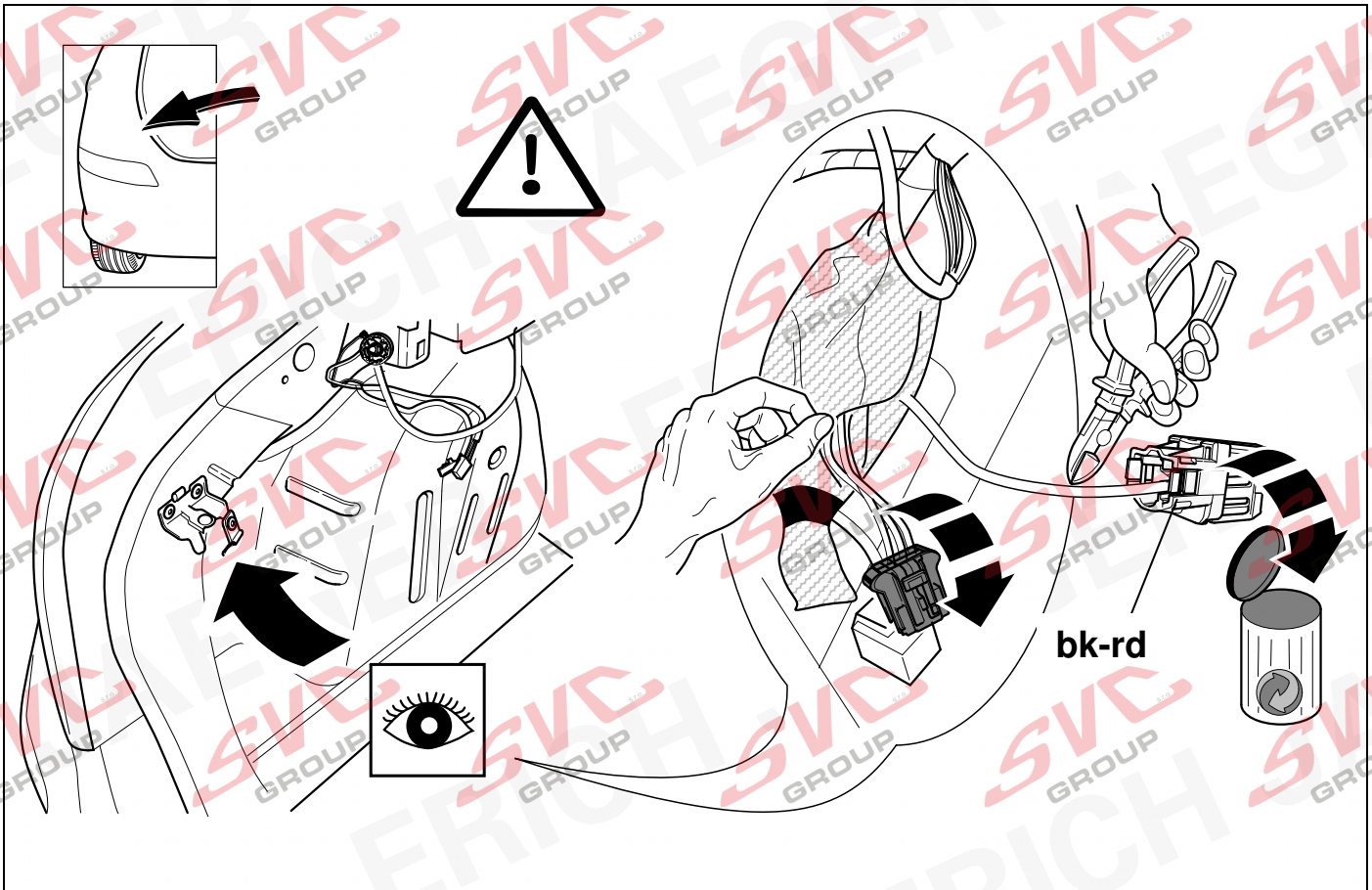

28

308



78

308 SW

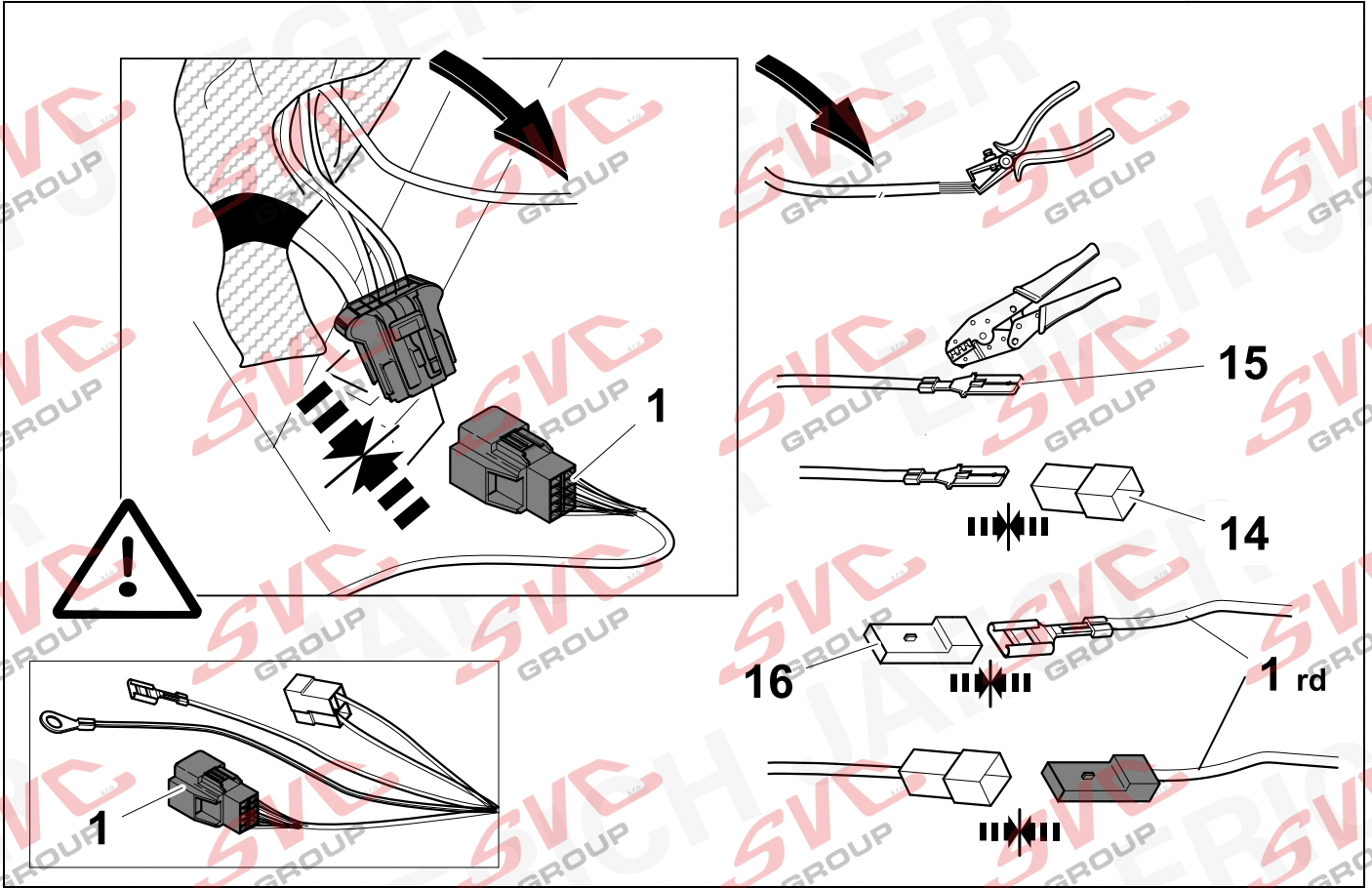

29

308

308 SW

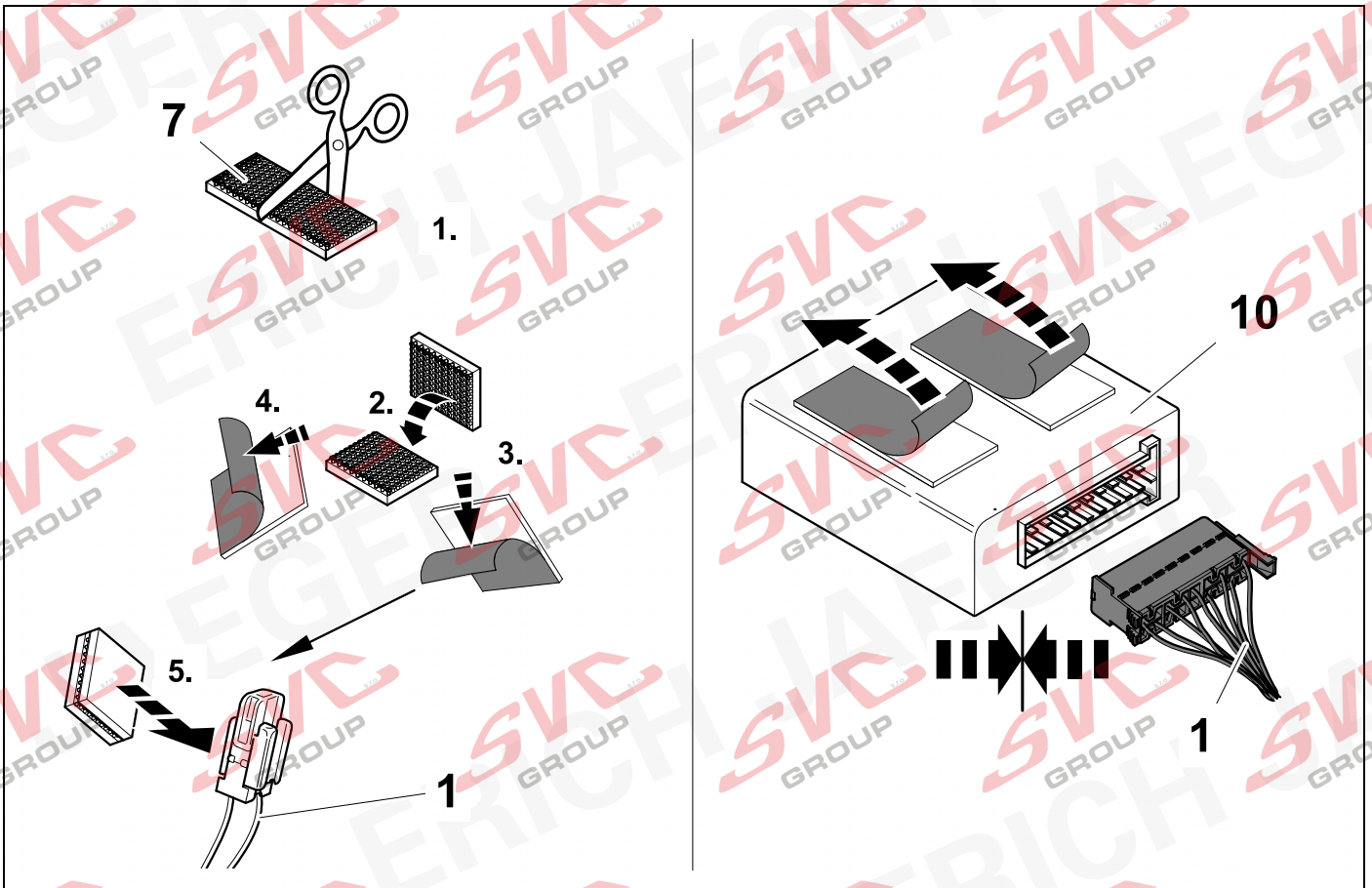

30

308

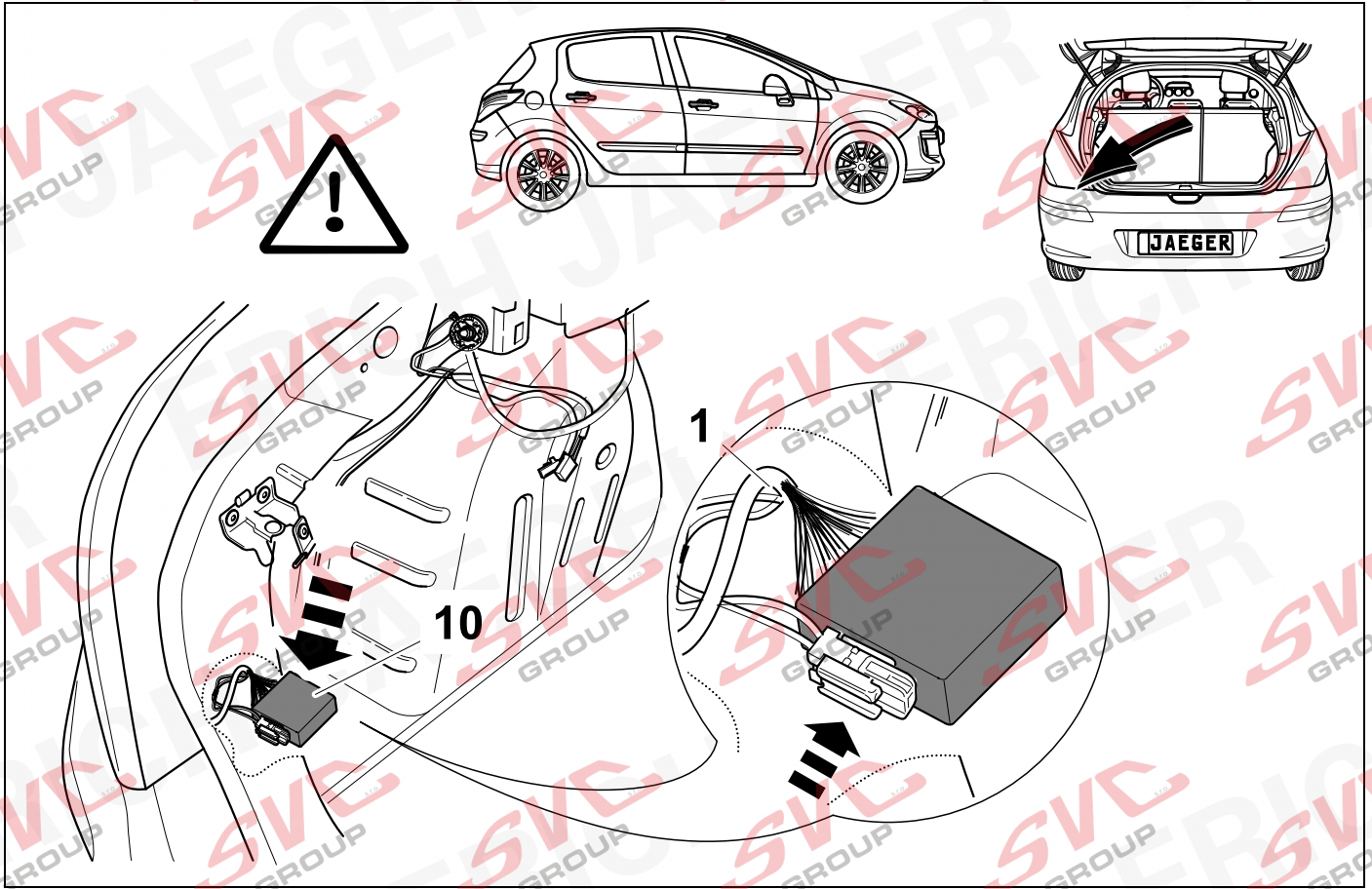

31

308 SW

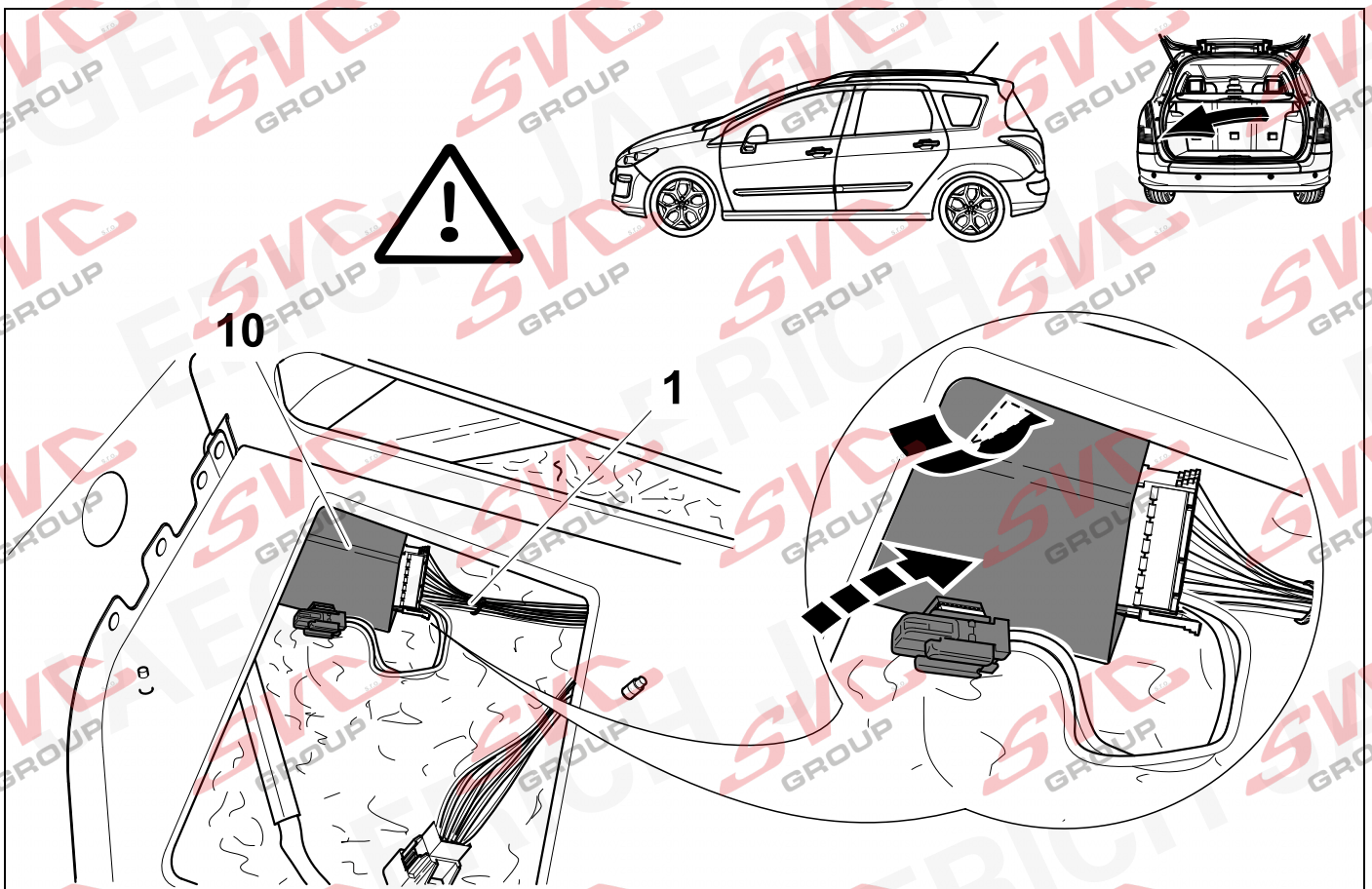



32

308

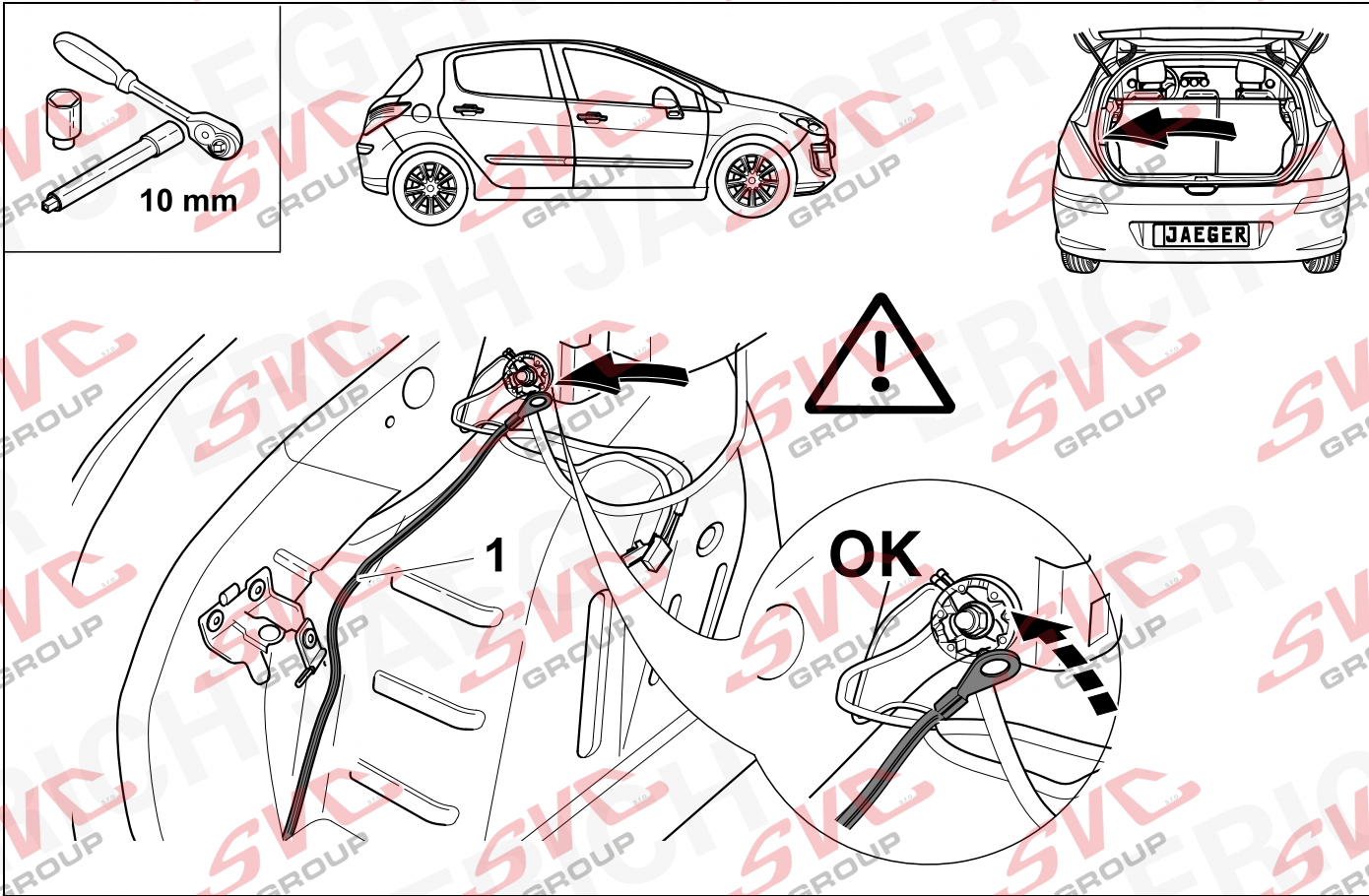

33

308 SW

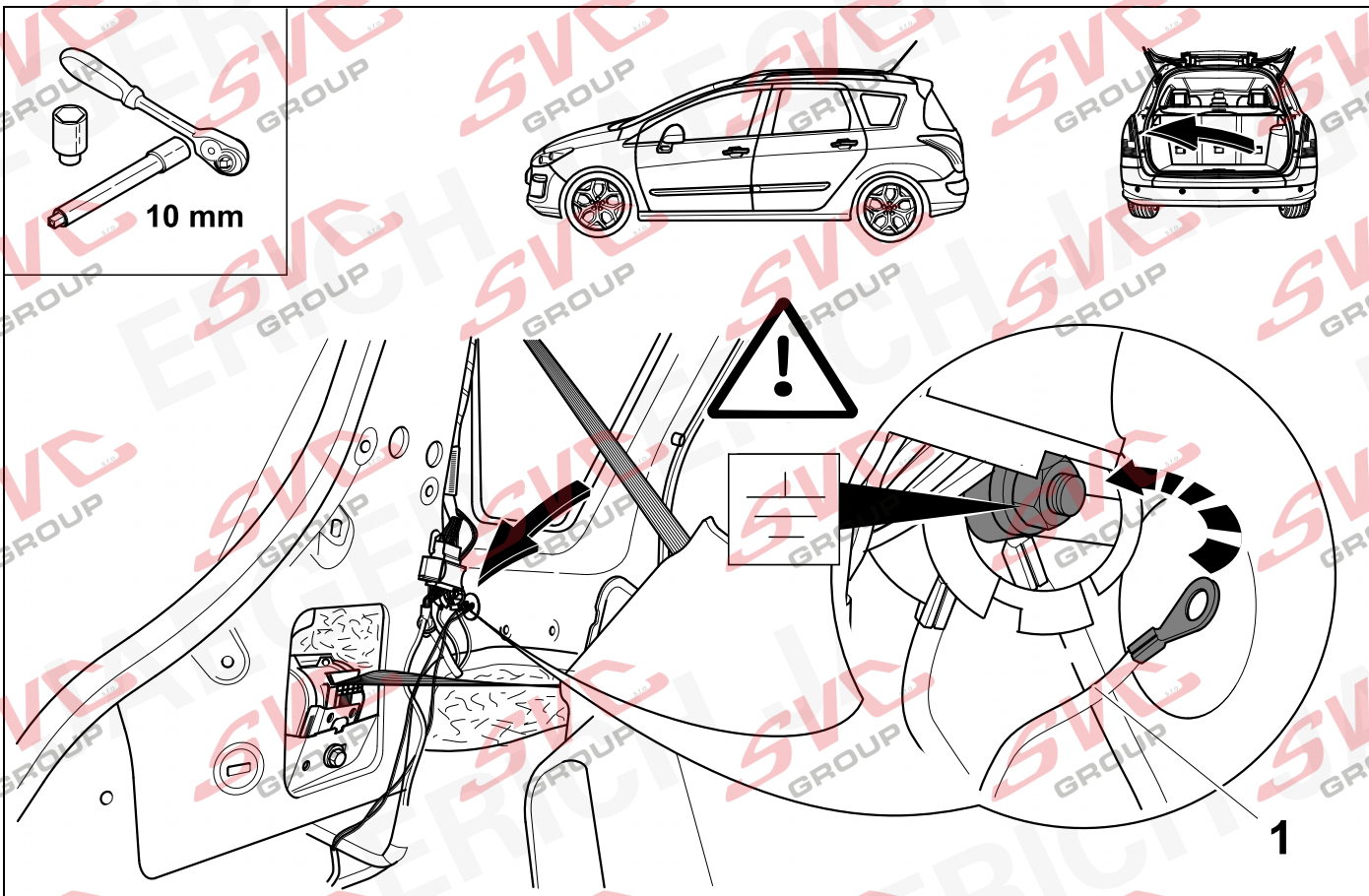

34

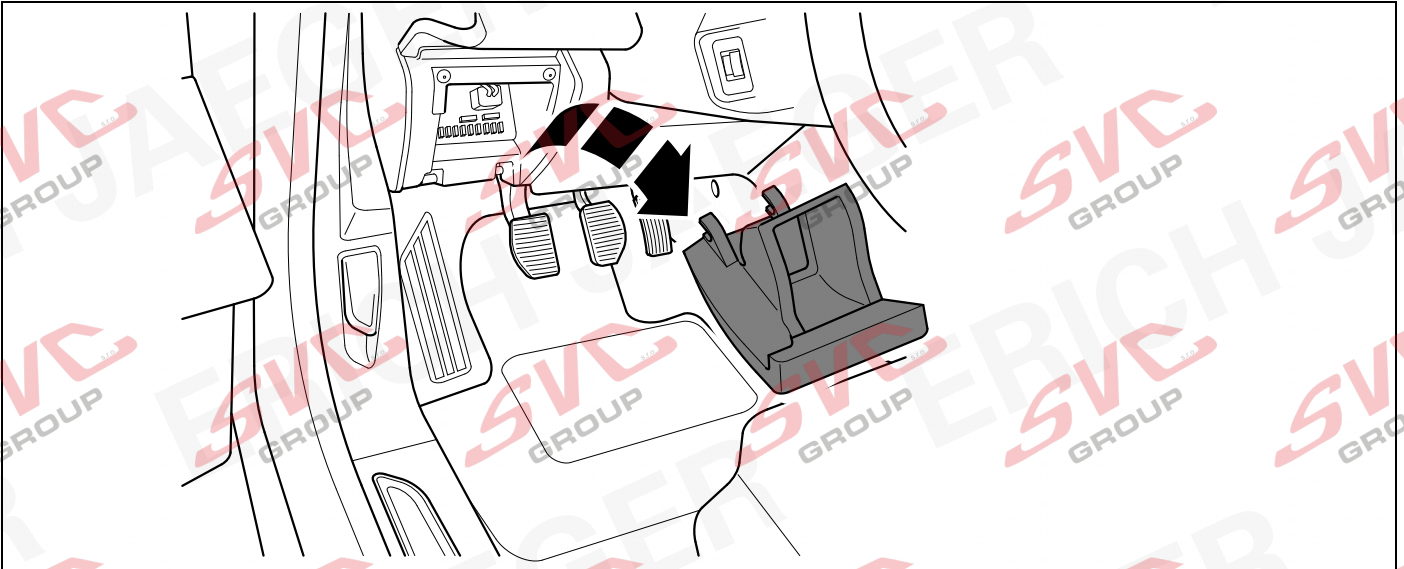

35

308

308 SW

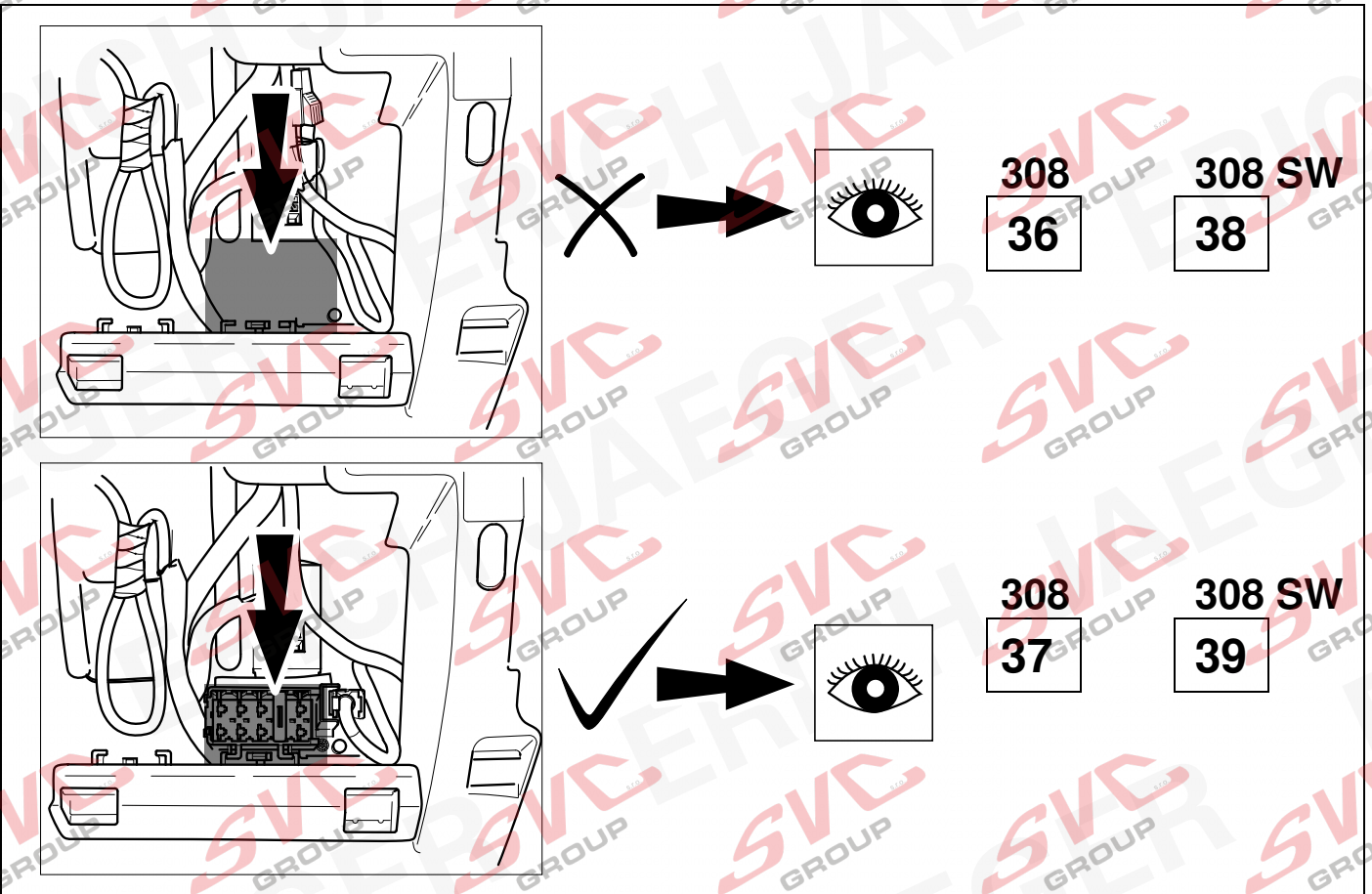

36

308



78

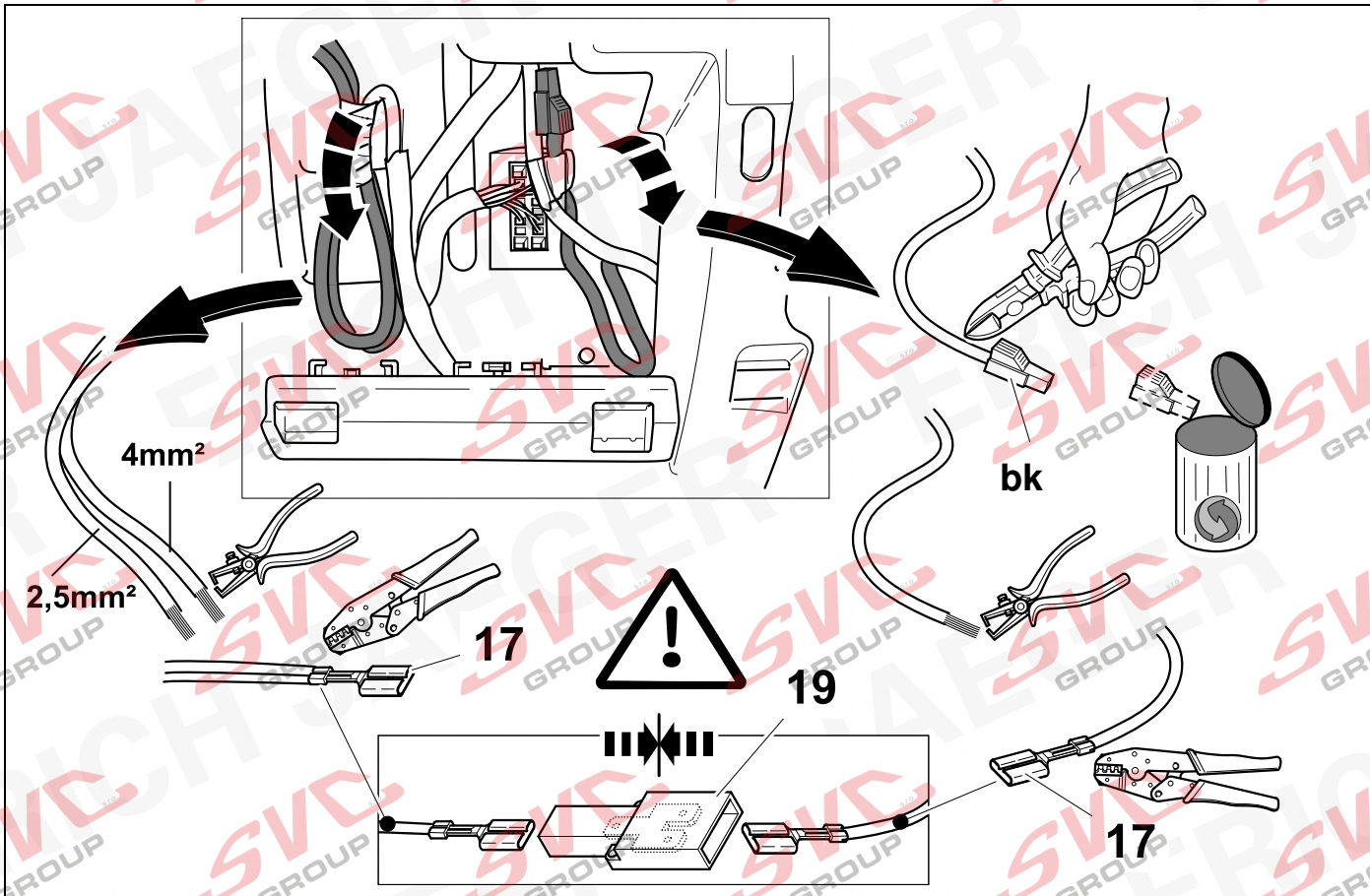

37

308

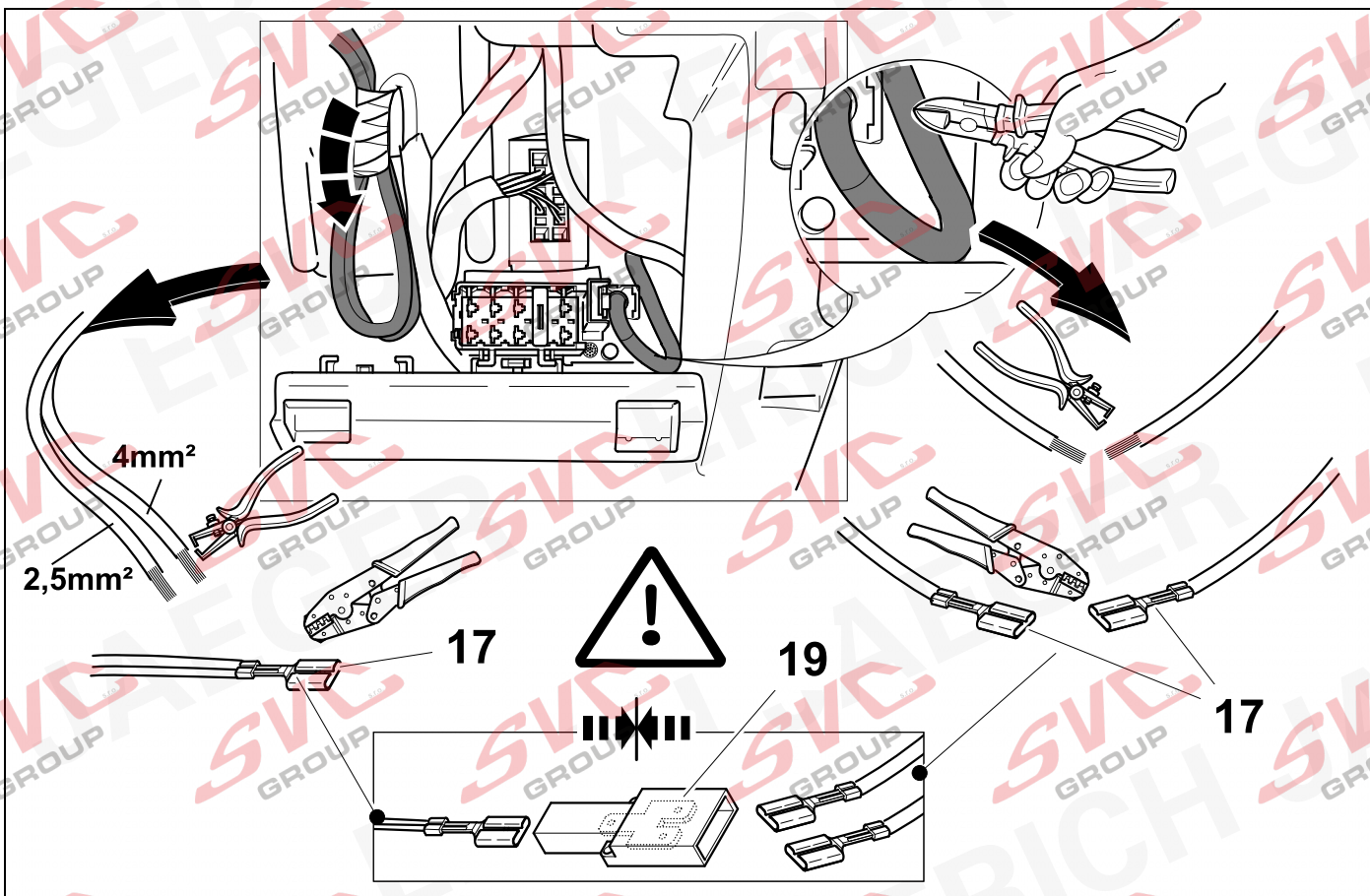

38



78

308 SW

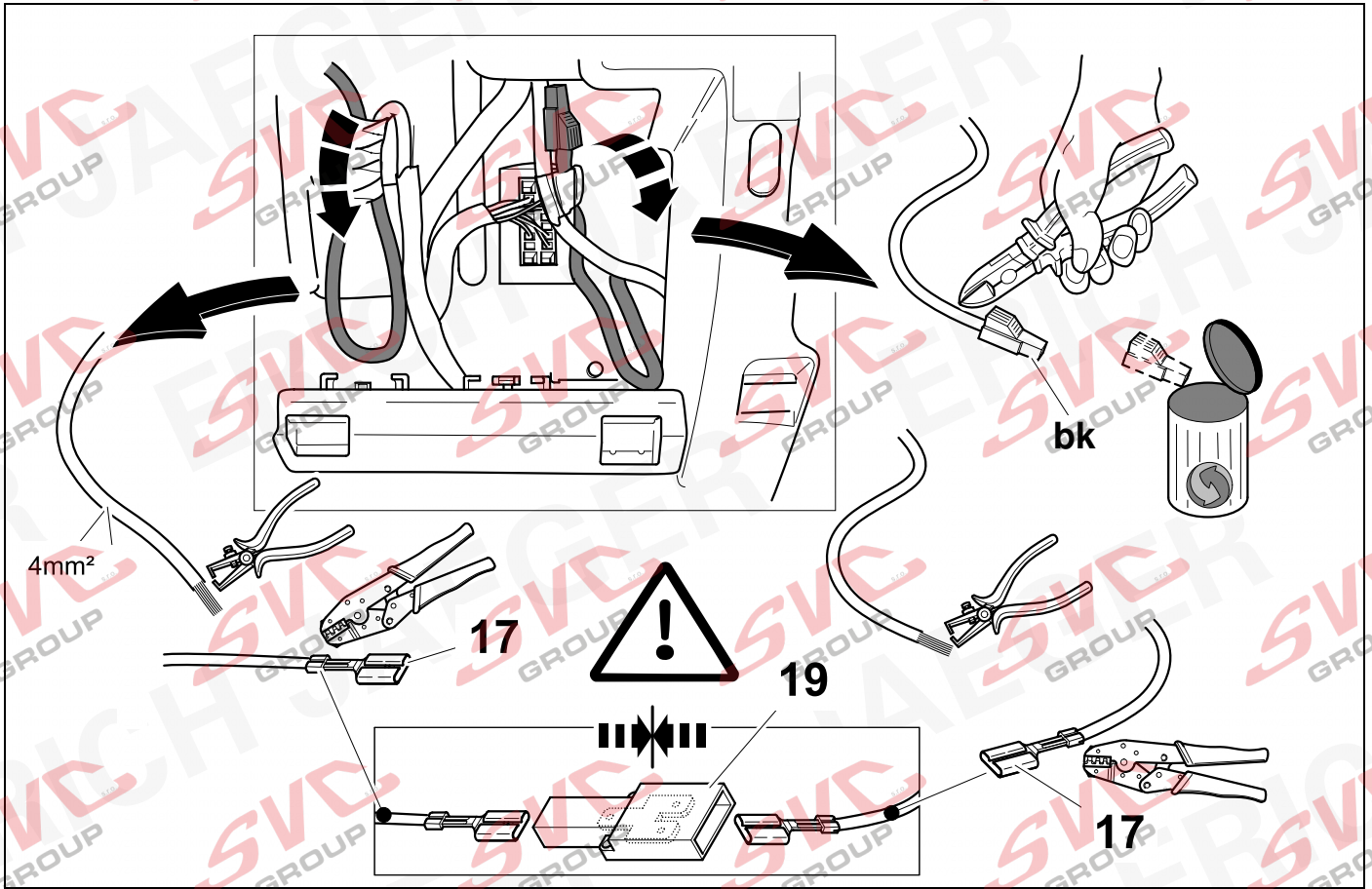

39



78

308 SW

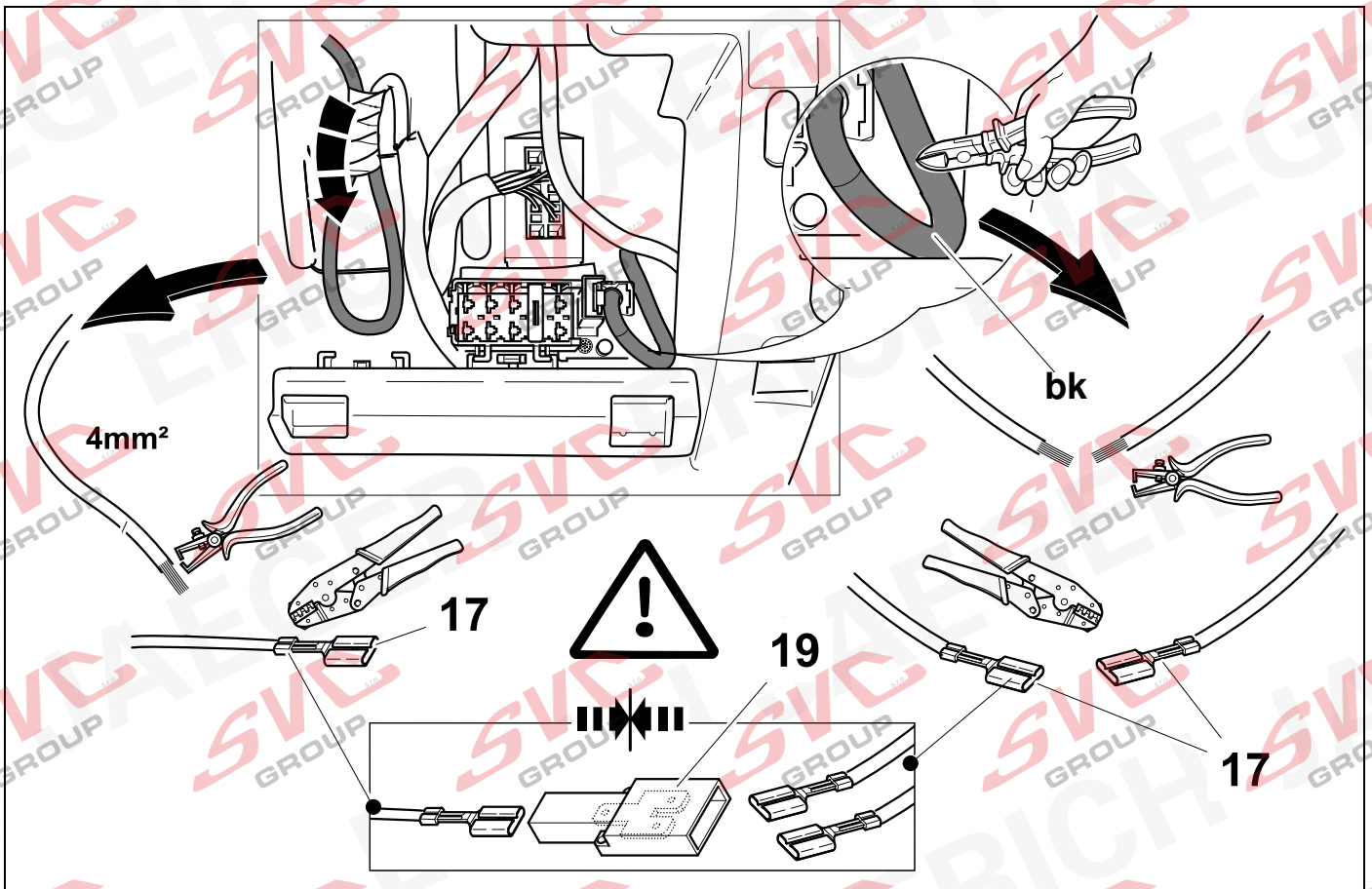

40

308

308 SW

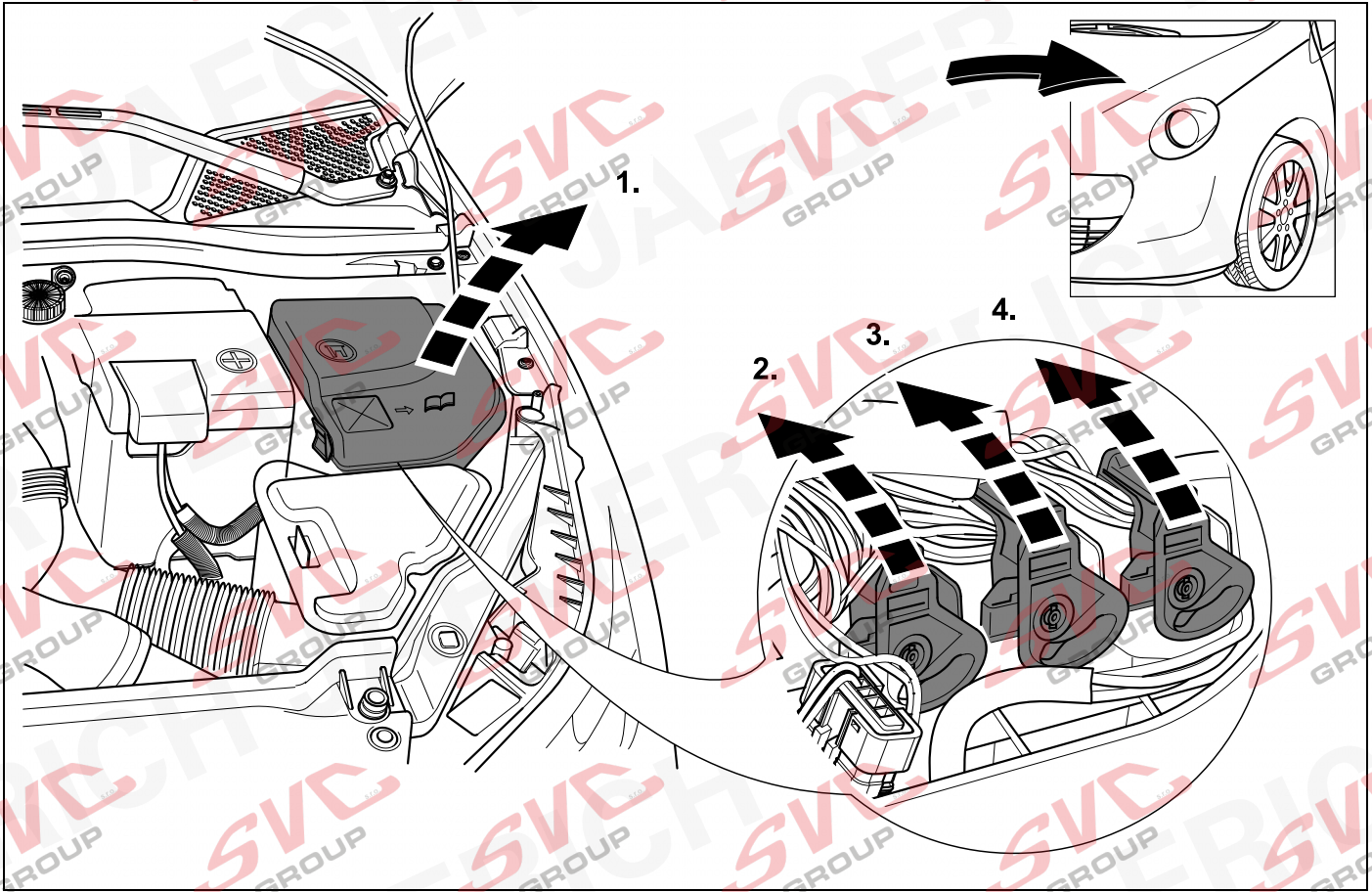

41

308

308 SW

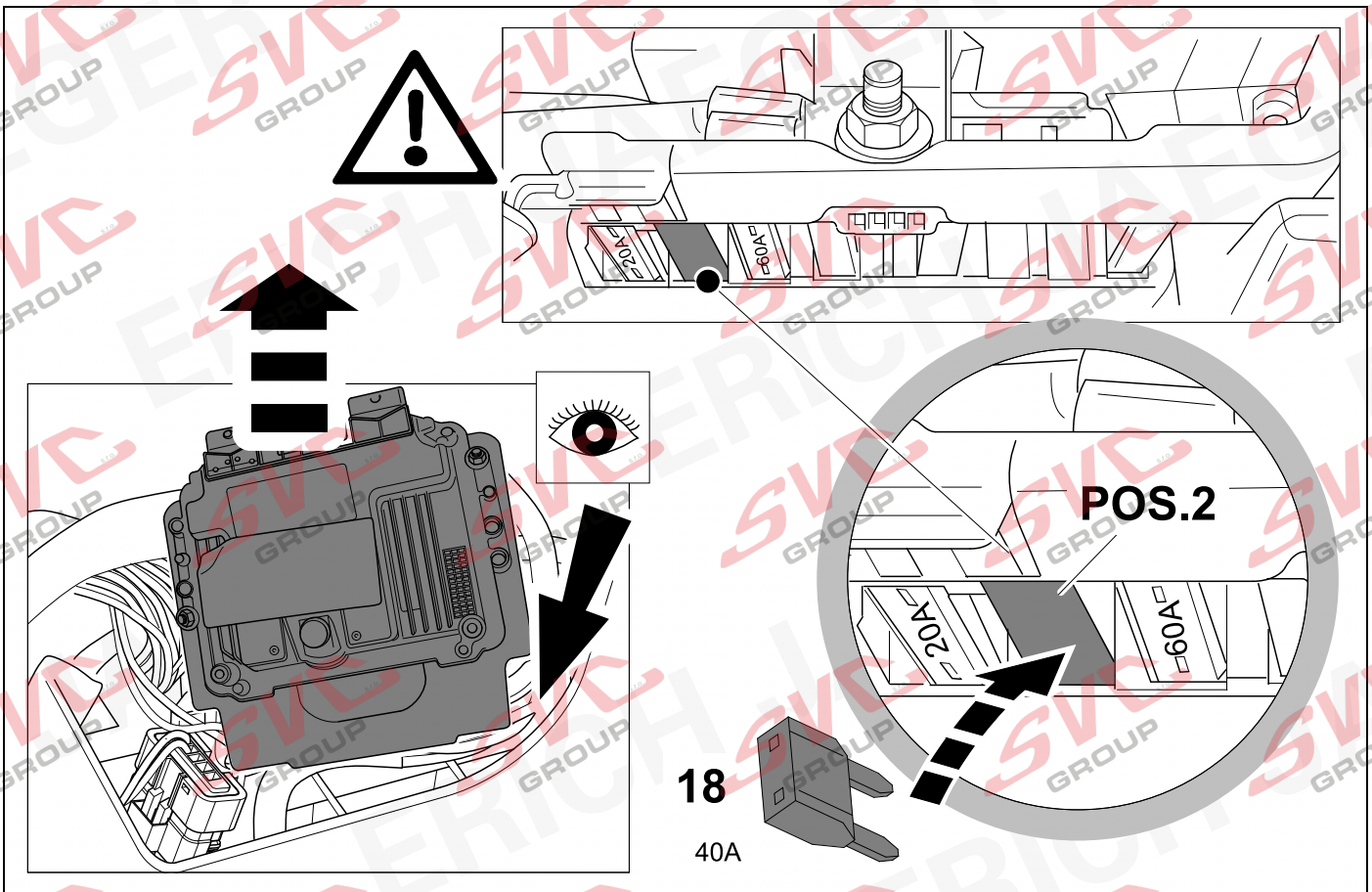

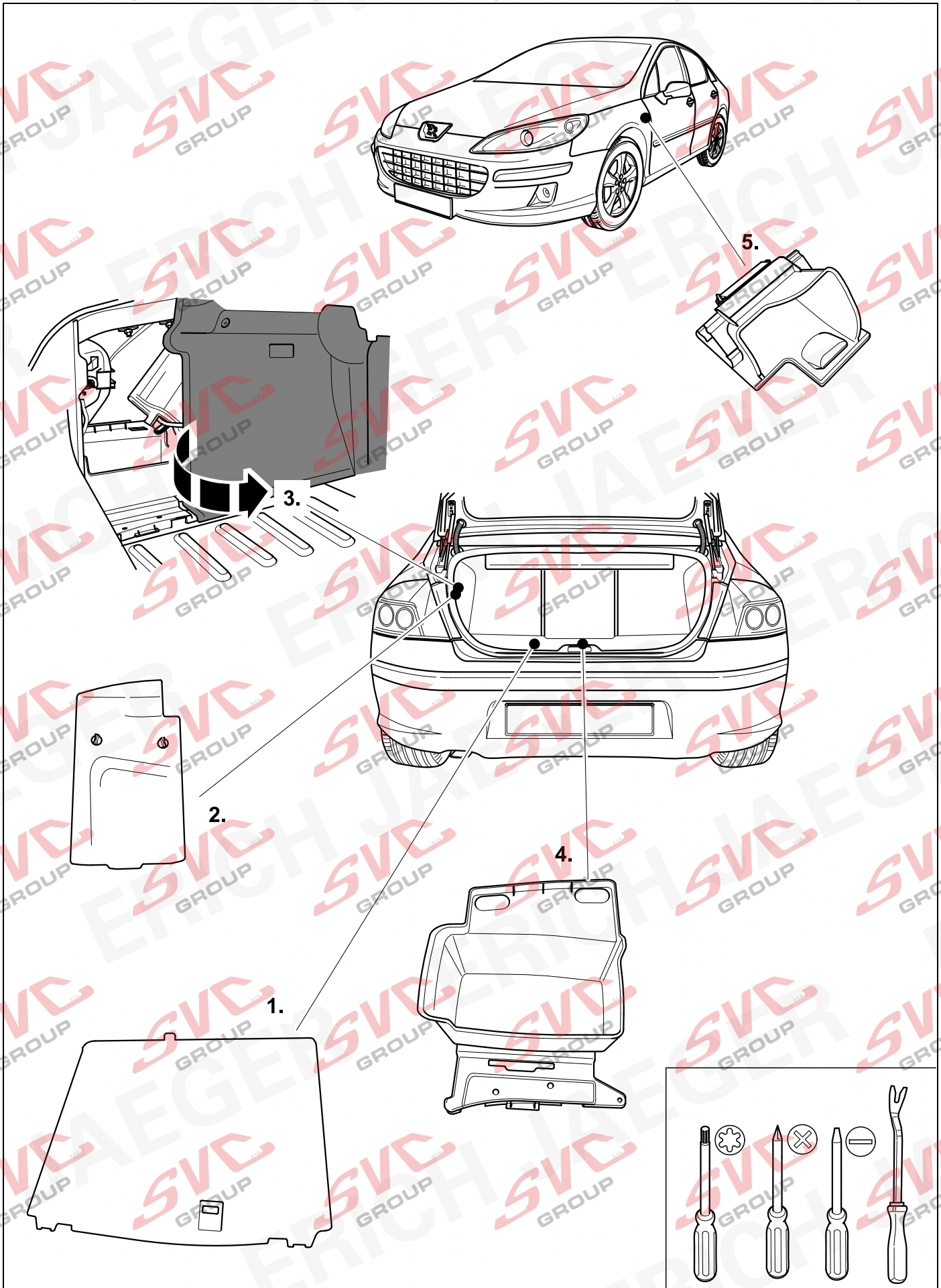

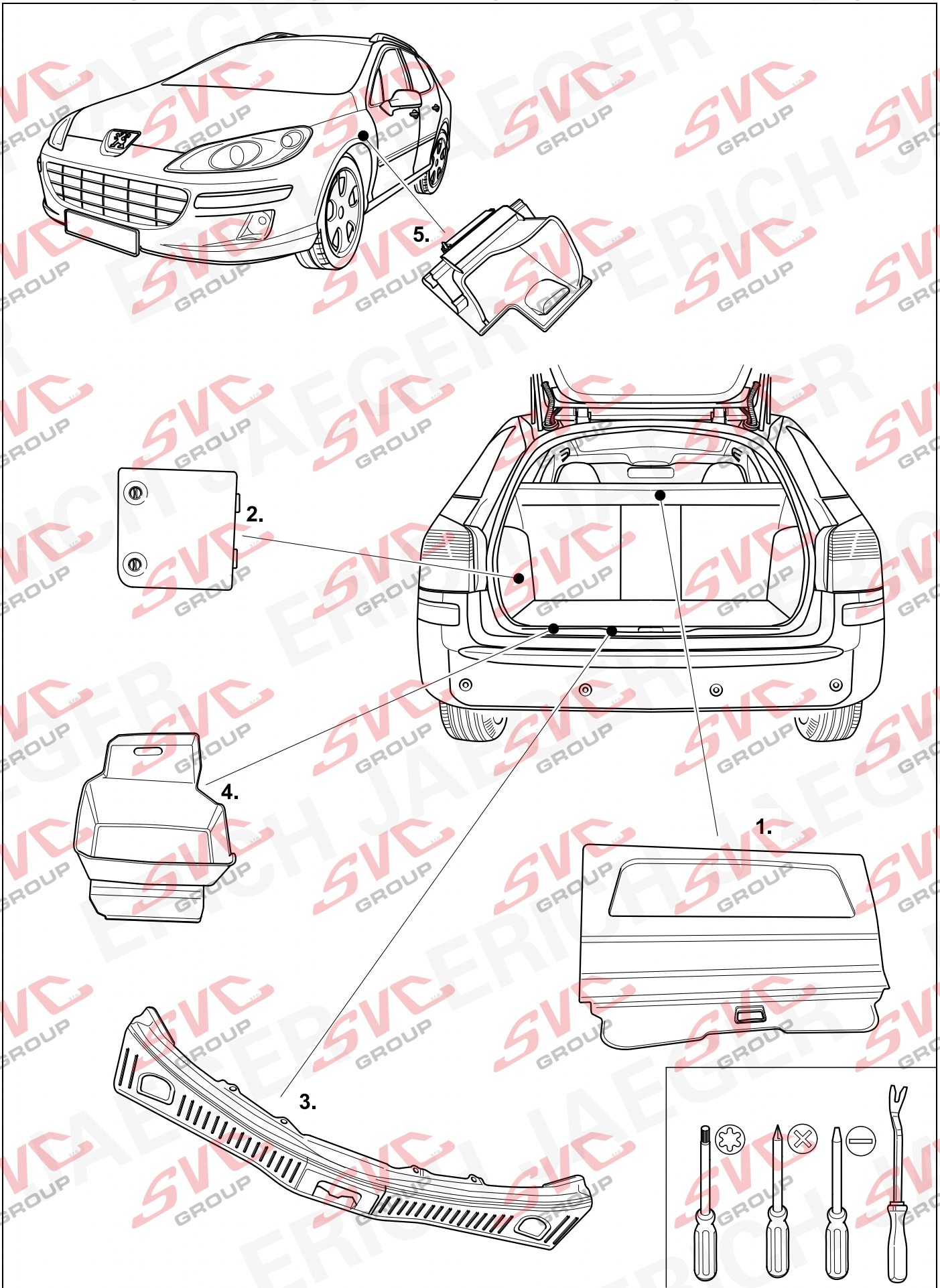

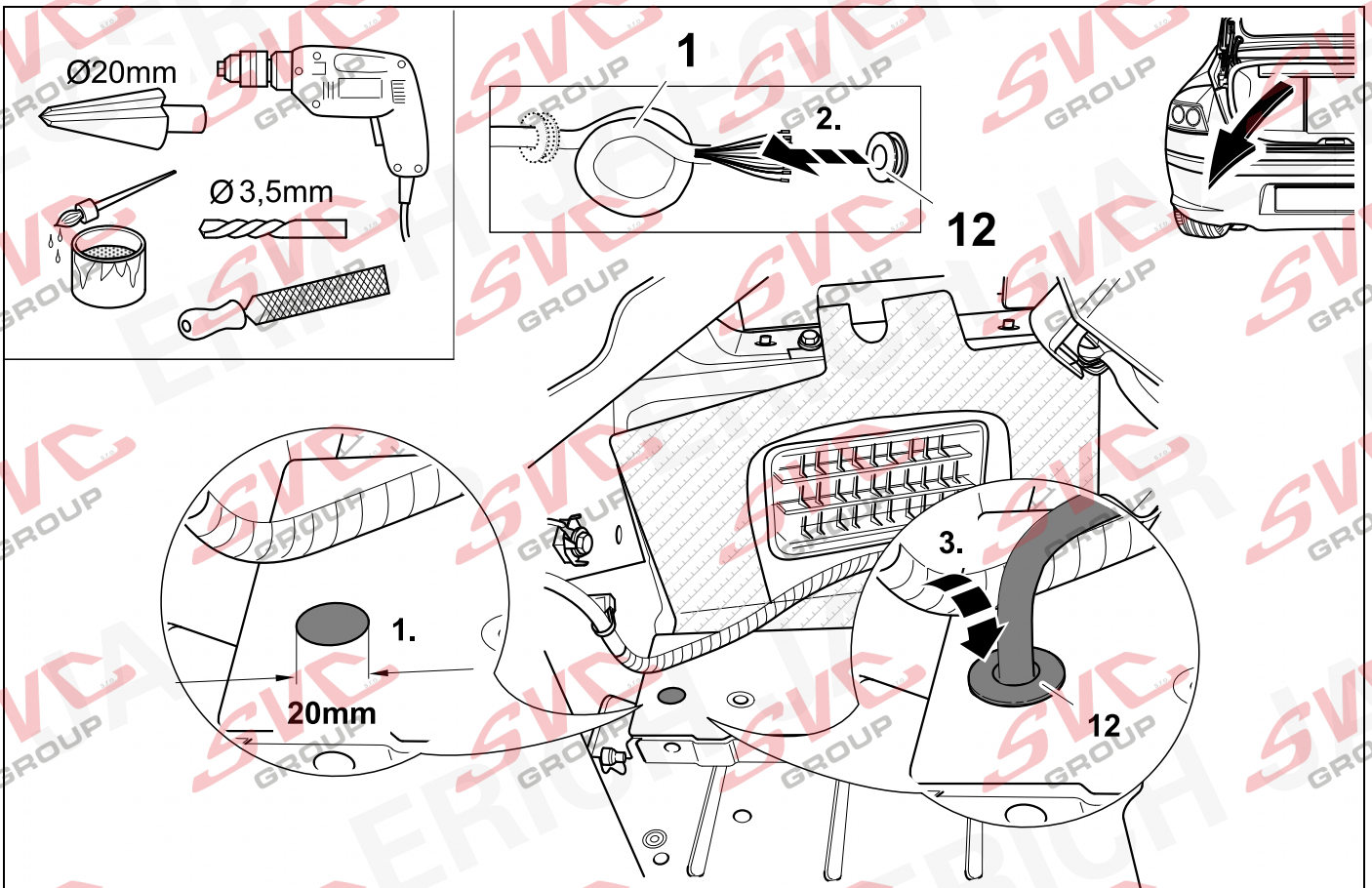
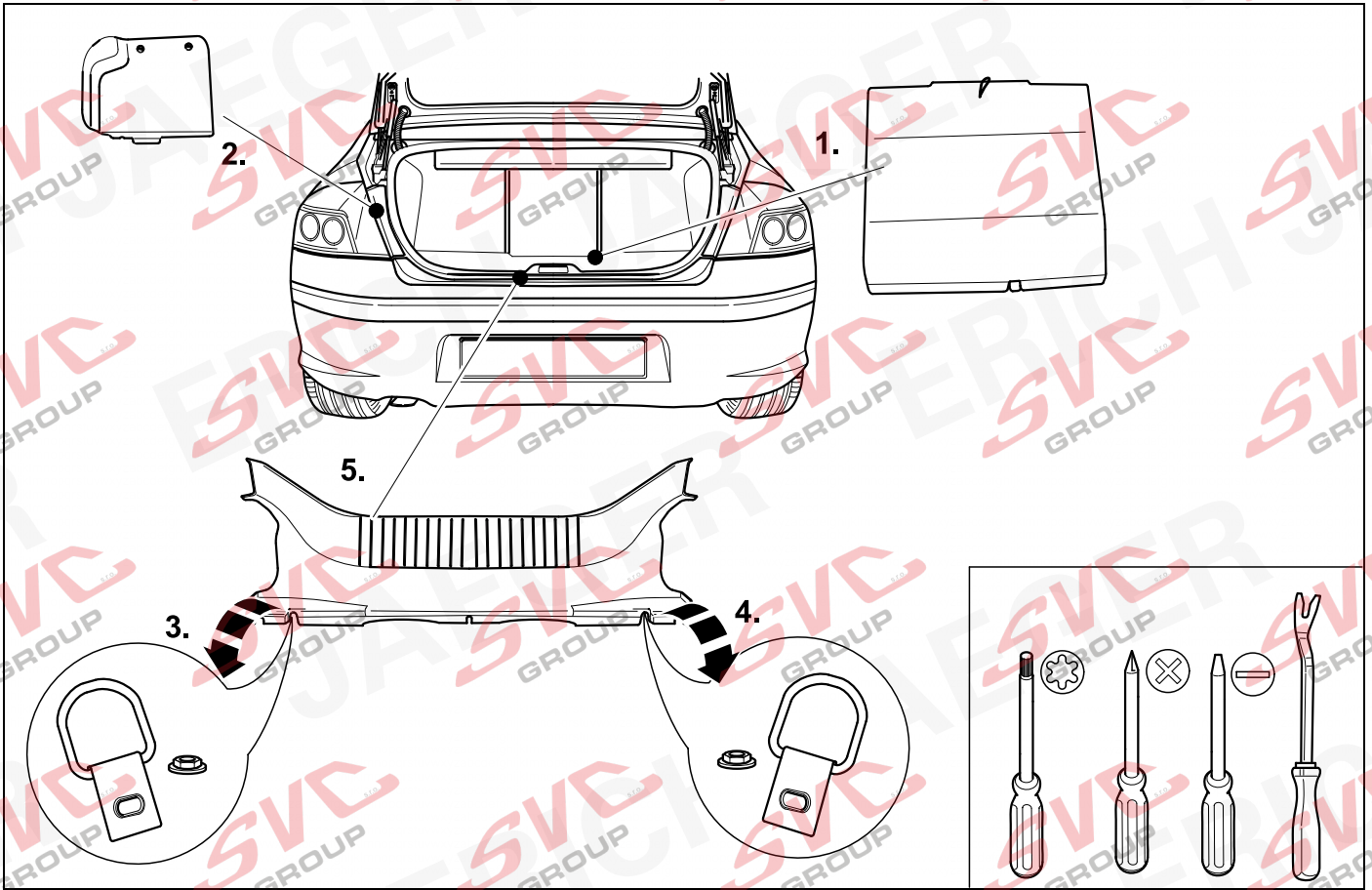



46

407 SW

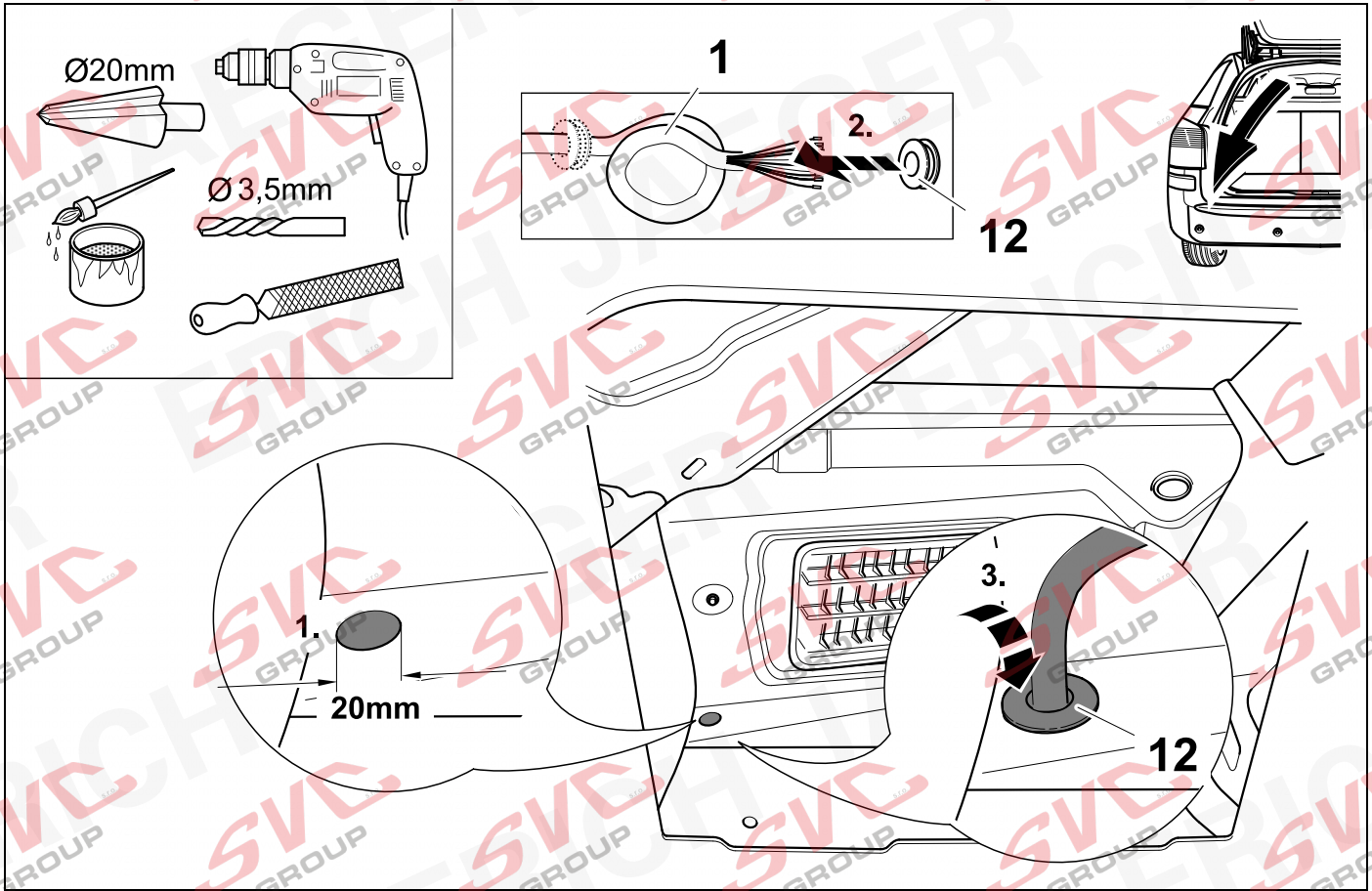

47

407 Coupé

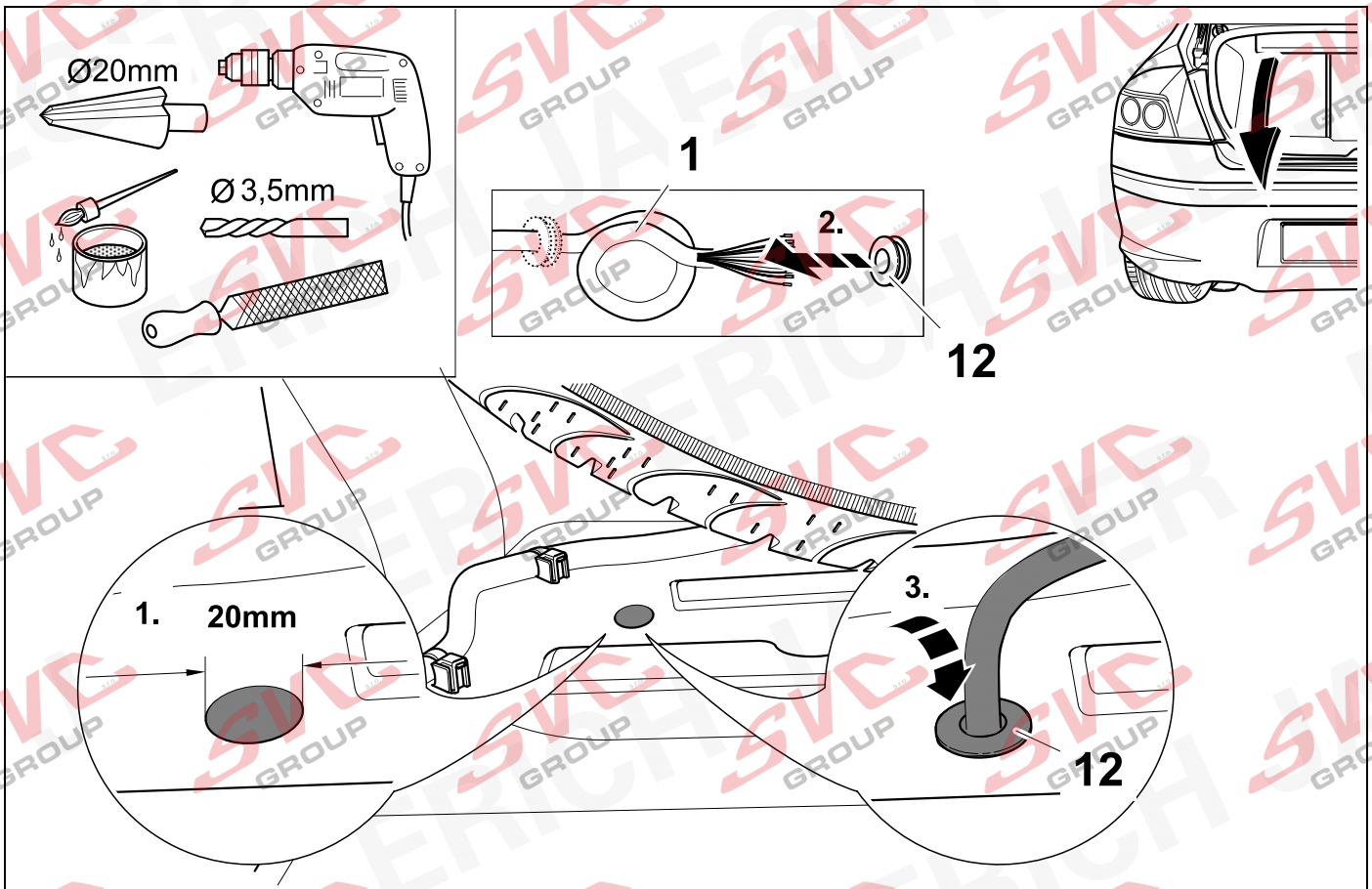

48

407

407 SW

407 Coupé

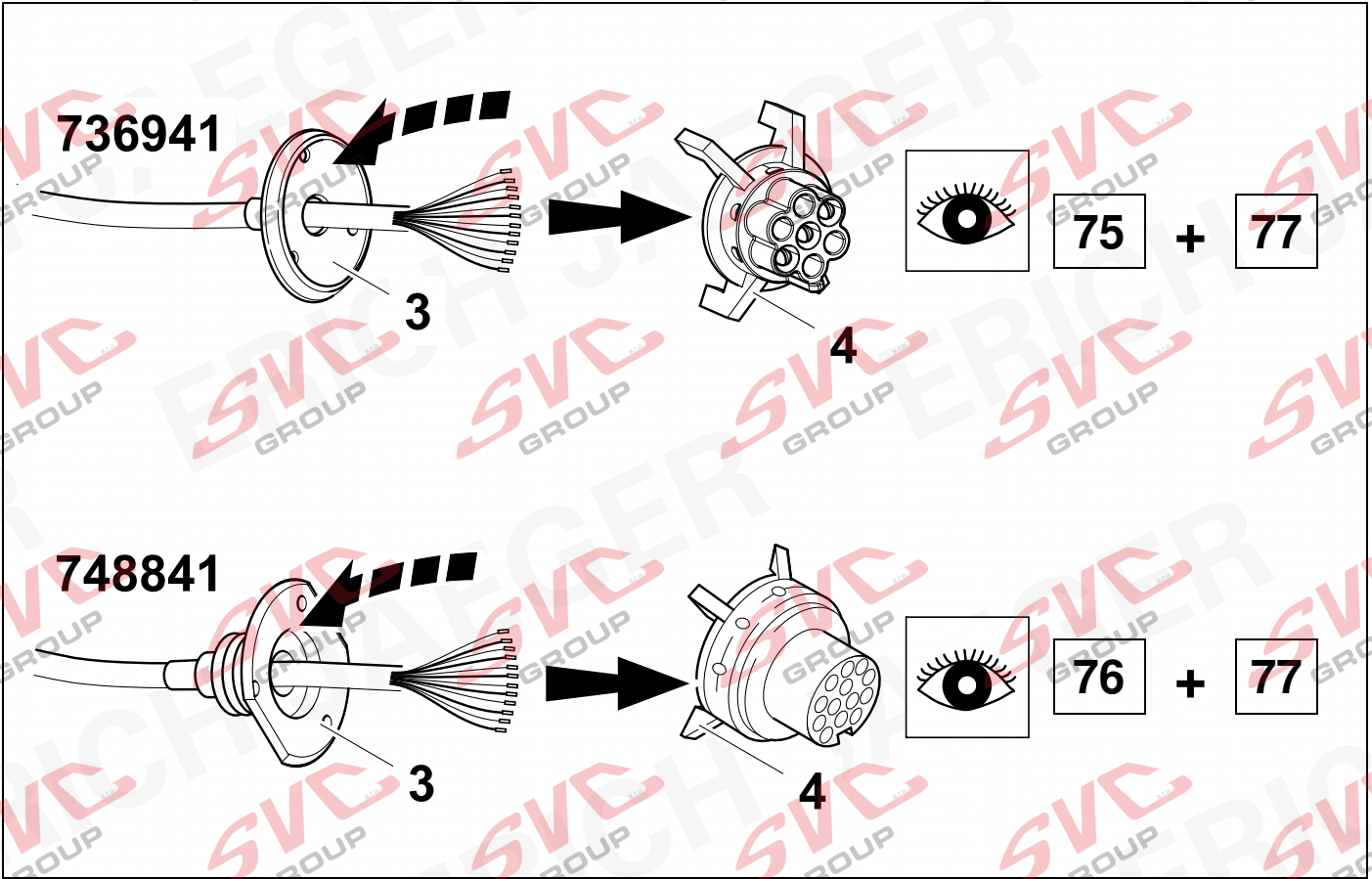

49

407 / 407 SW >> 08/08

407 Coupé

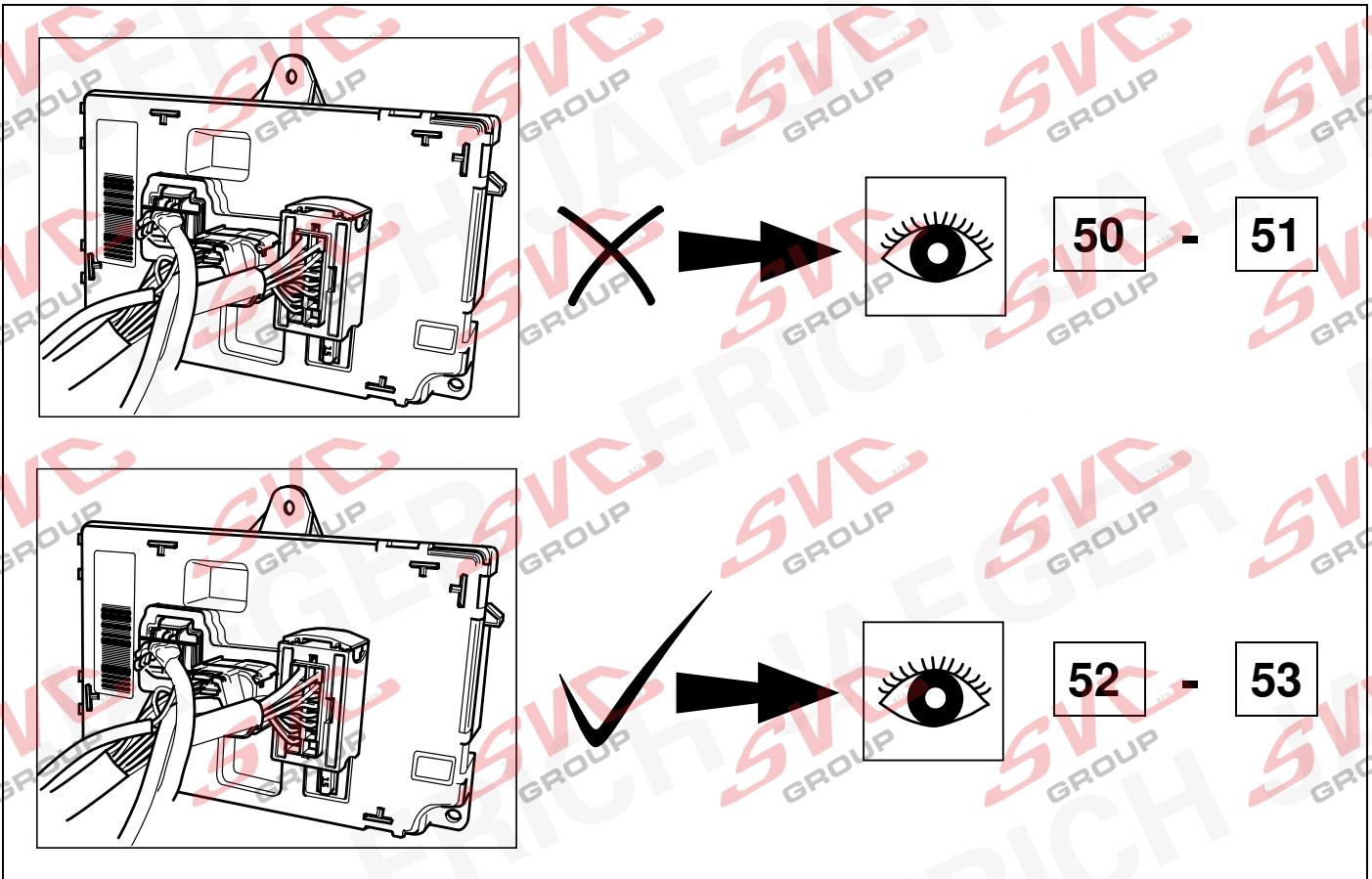

50



78

407 / 407 SW >> 09/08

407 Coupé

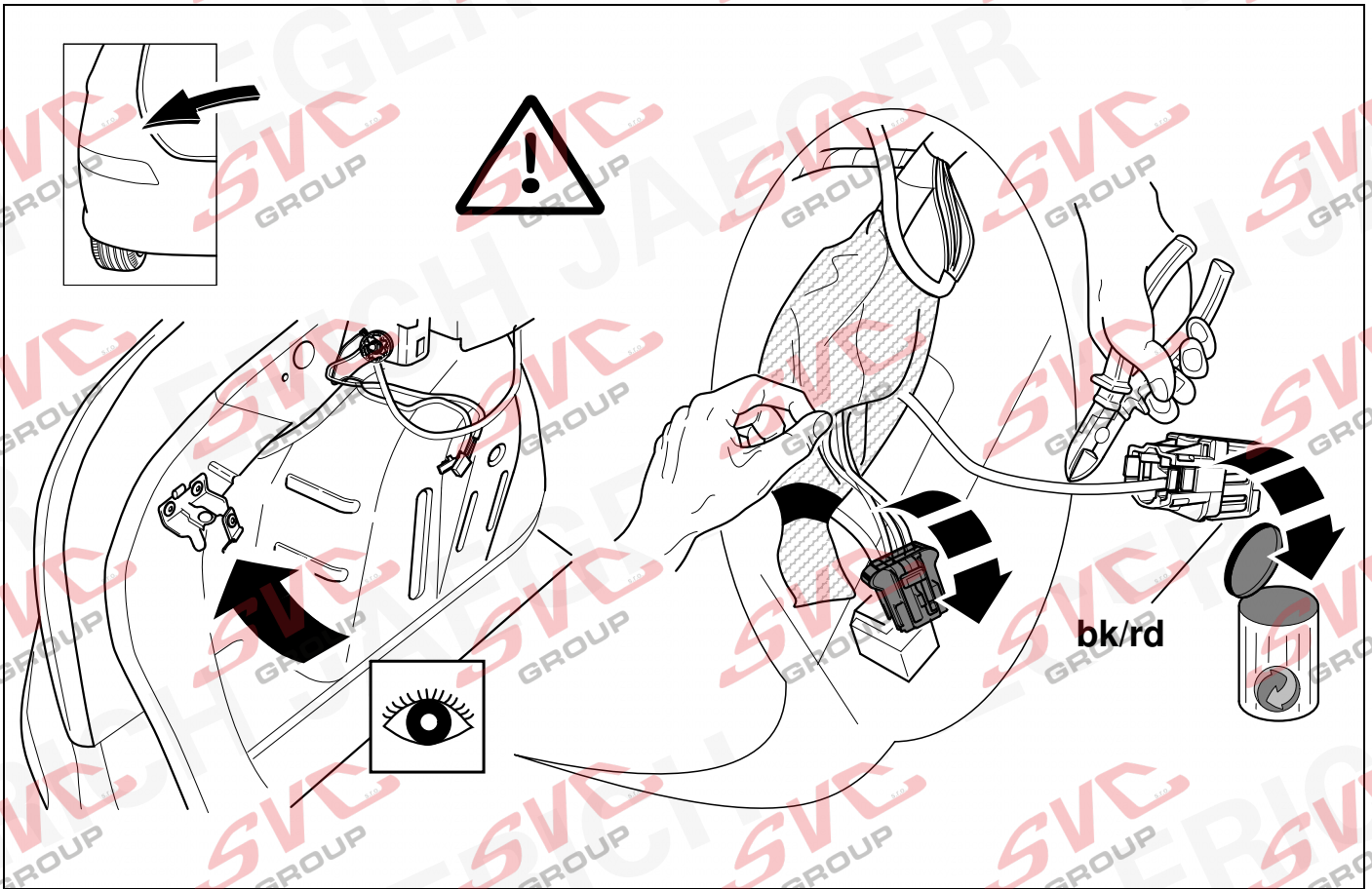

51



78

407 / 407 SW >> 09/08

407 Coupé

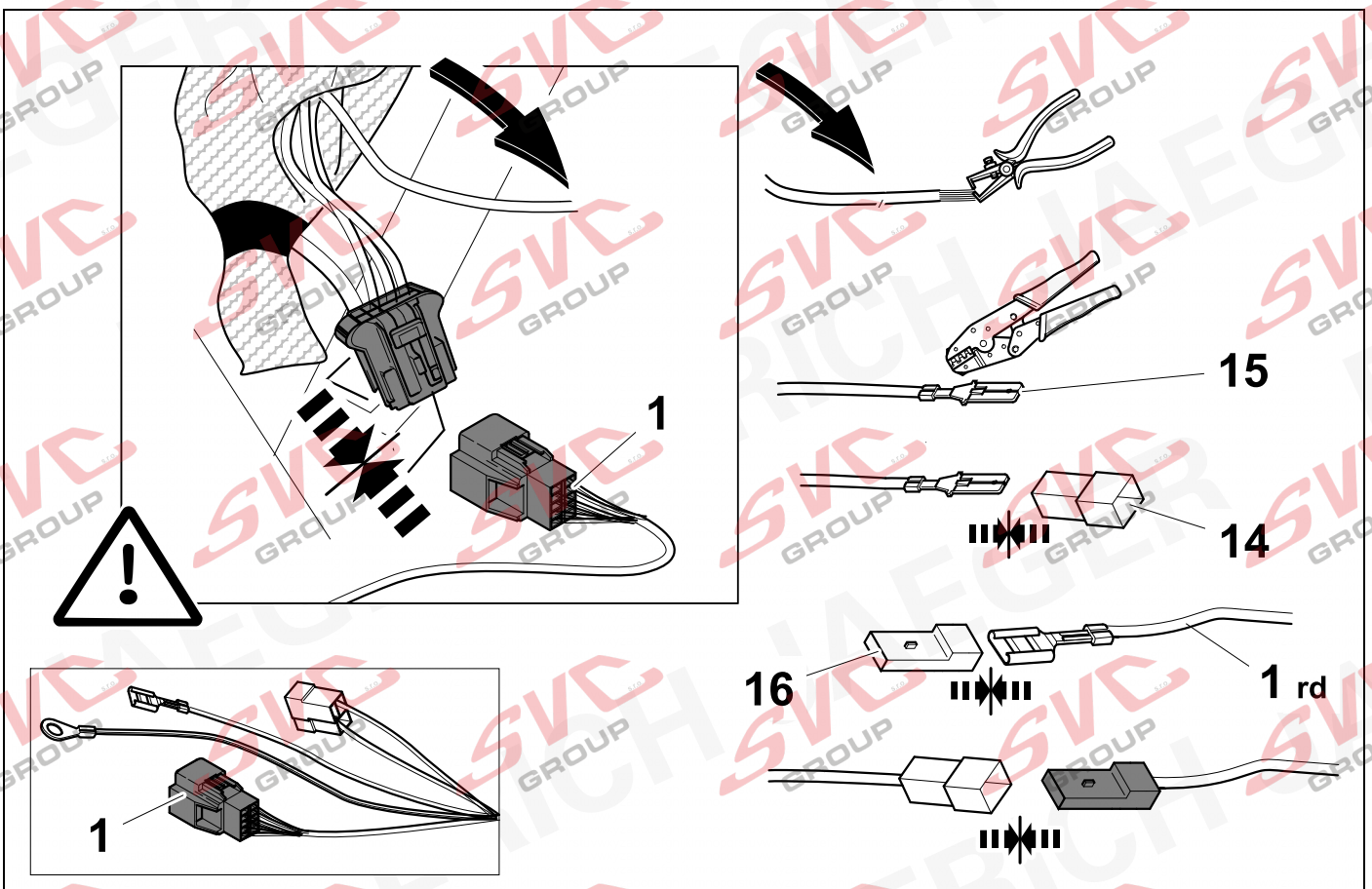

52



78

407 / 407 SW >> 09/08

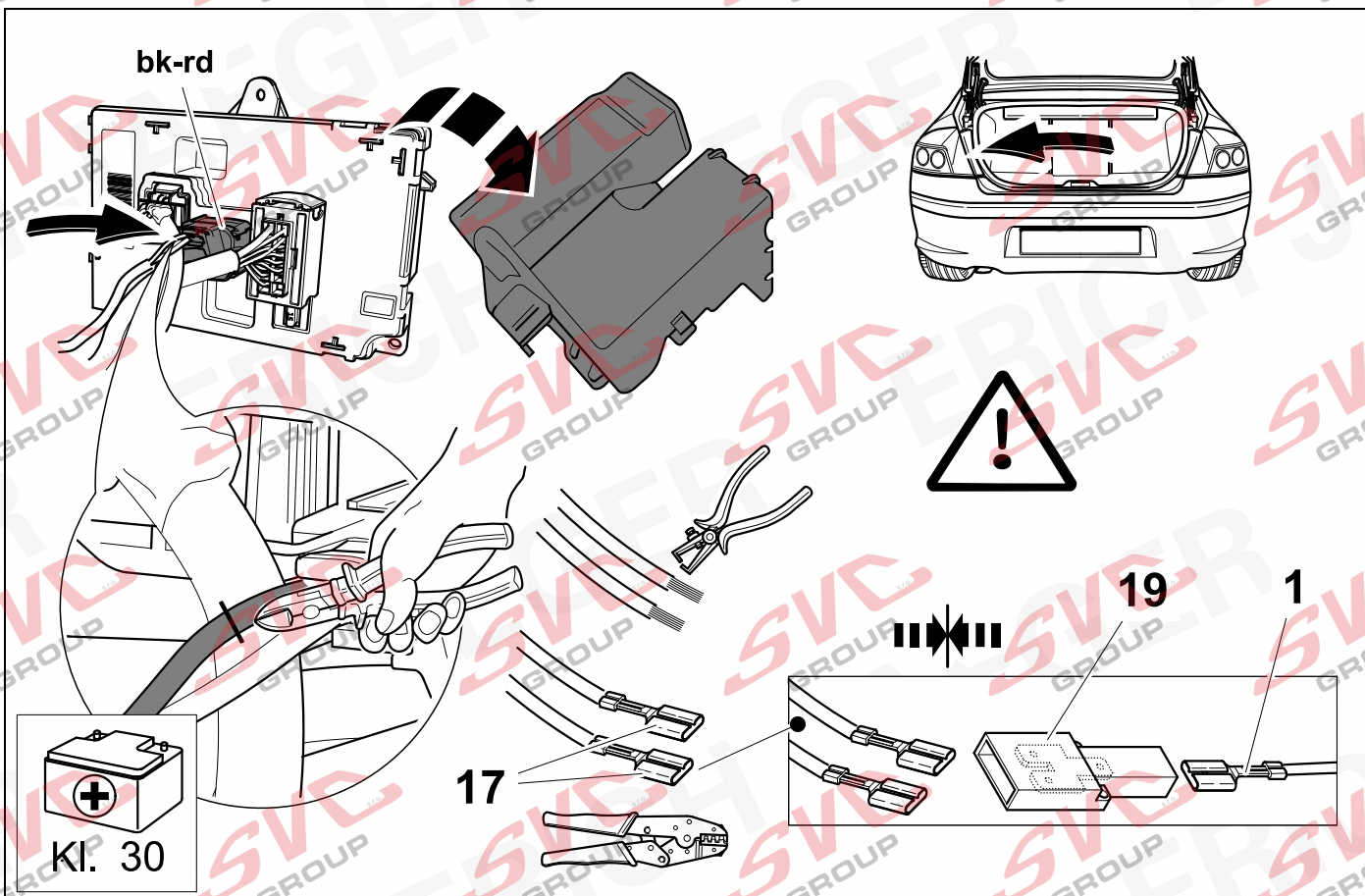

53



78

407 / 407 SW >> 09/08

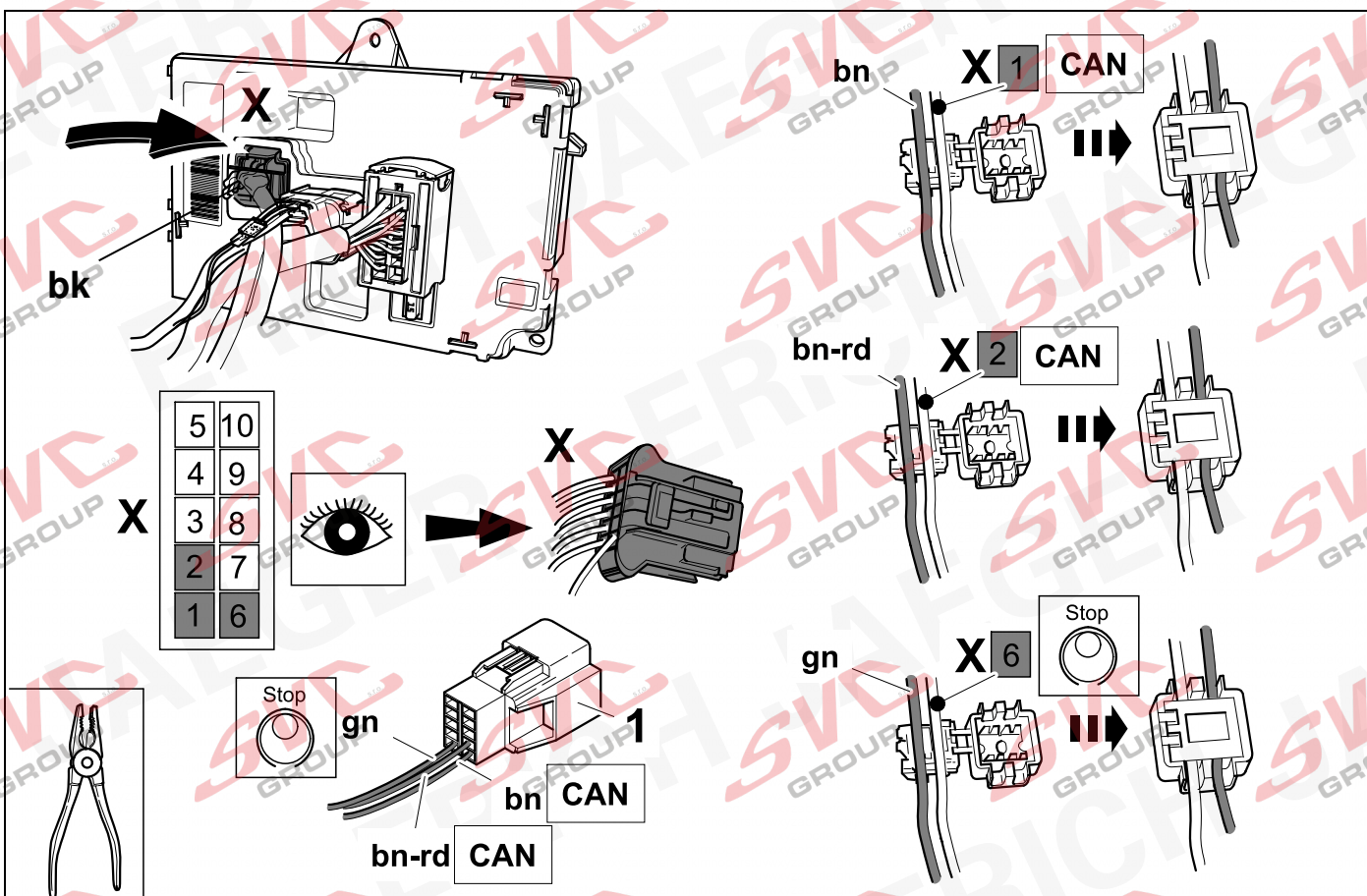

54



78

407 / 407 SW 10/08 >>

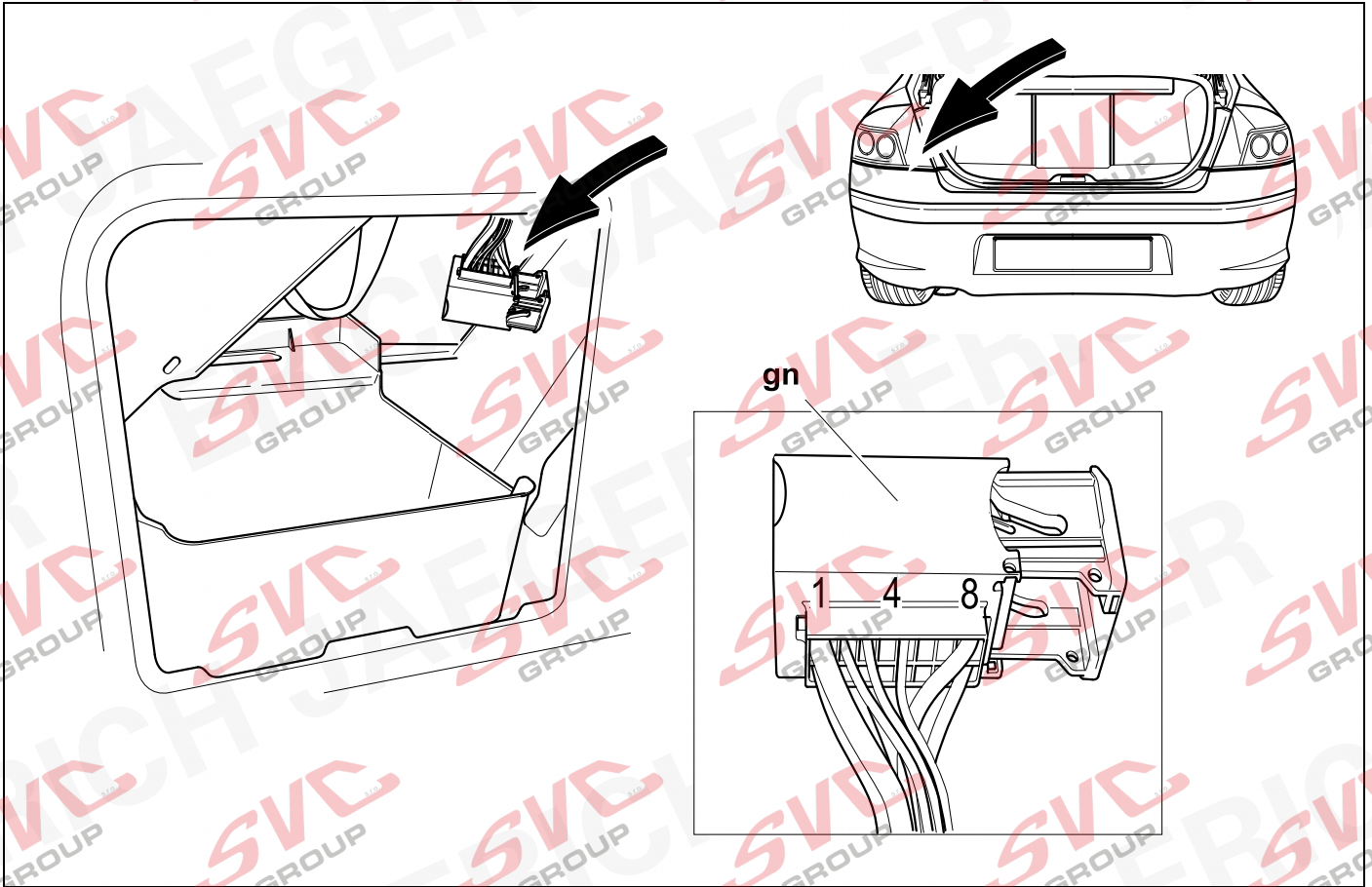

55



78

407 / 407 SW 10/08 >>

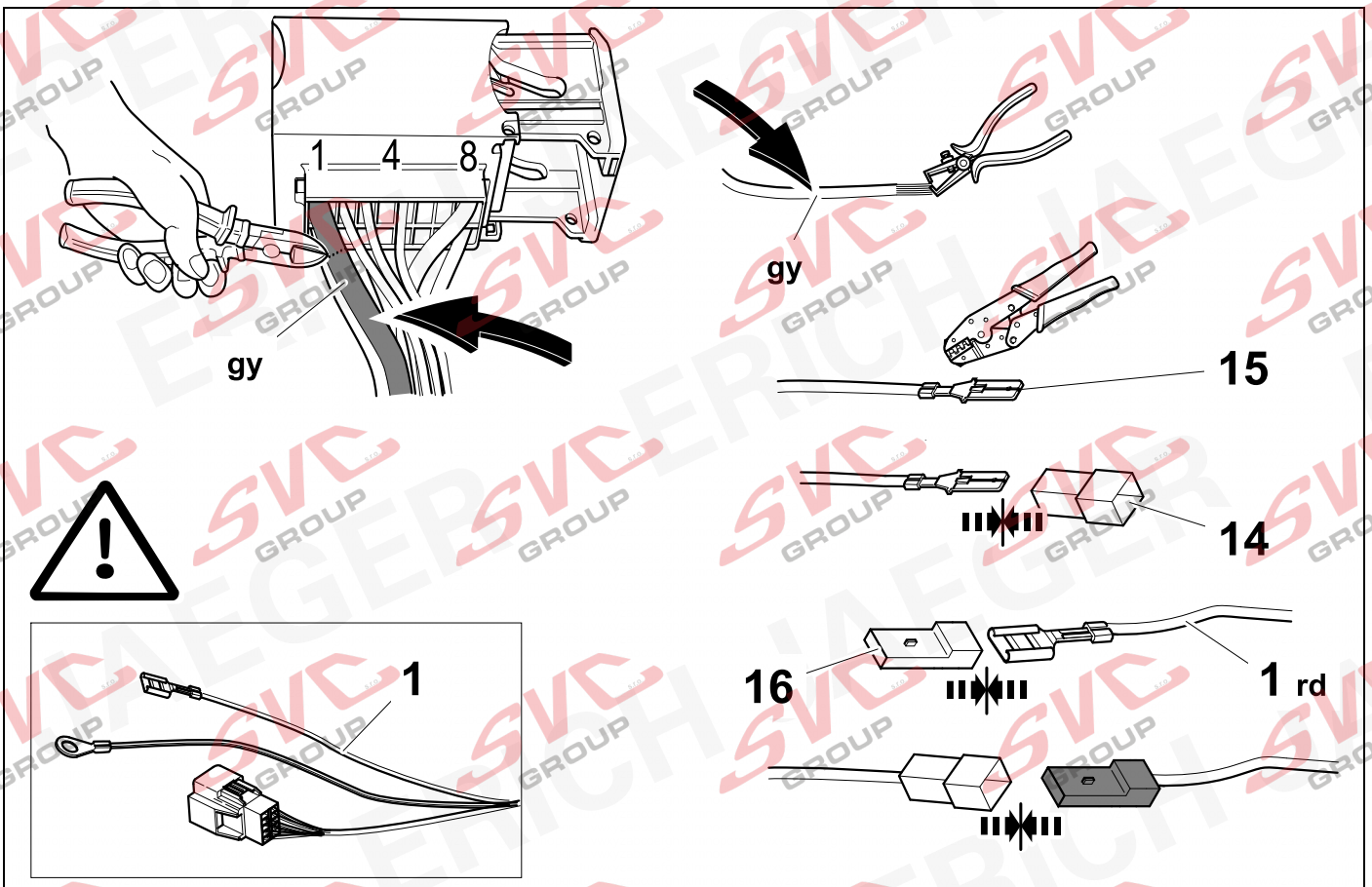

56



78

407 / 407 SW 10/08 >>

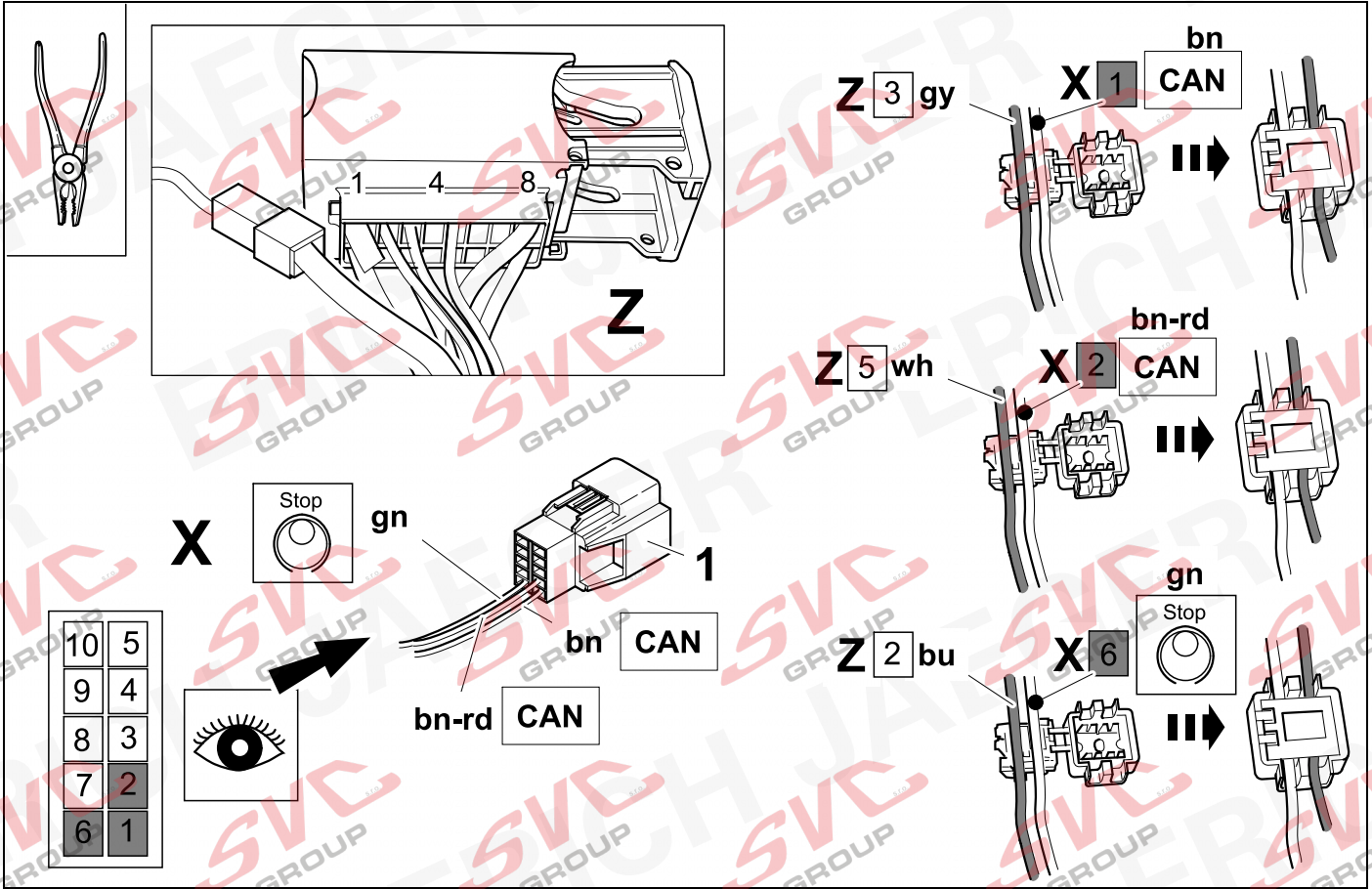

57

407

407 SW

407 Coupé

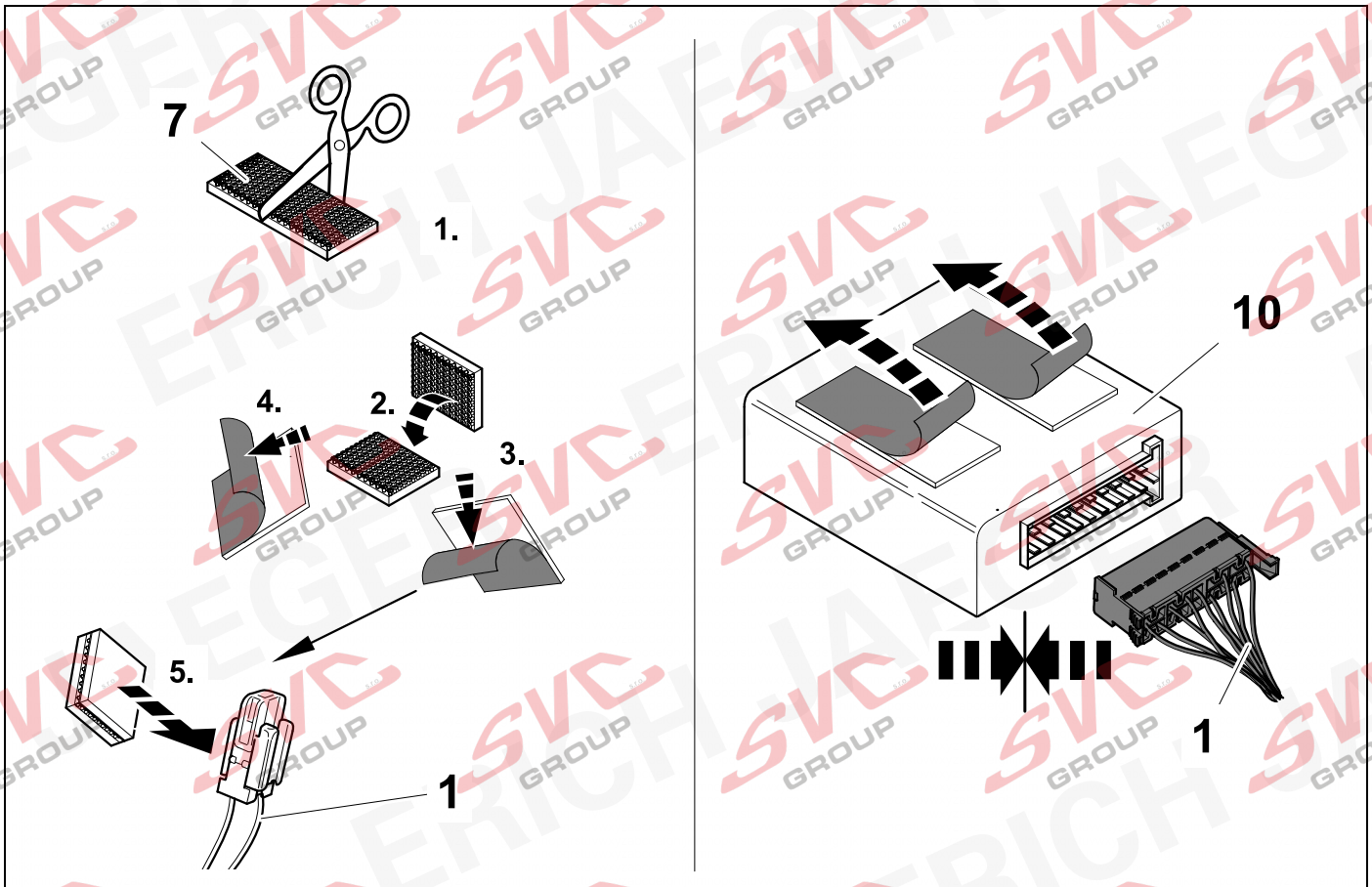

58

407

407 SW

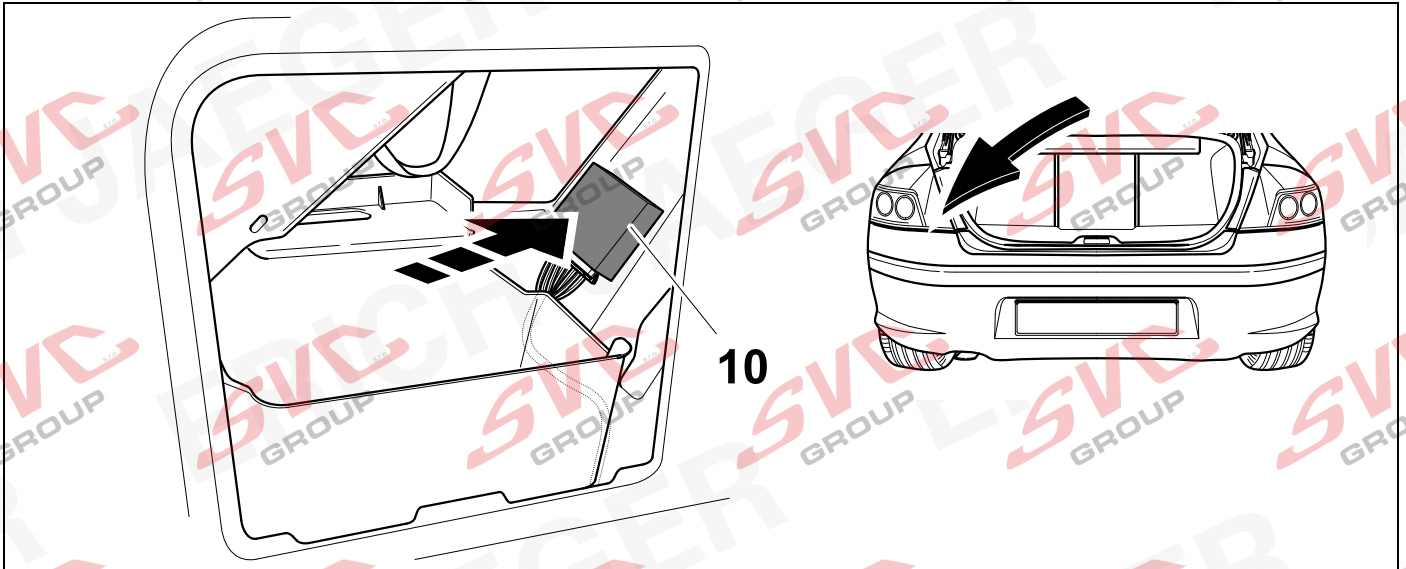

59

407

407 SW

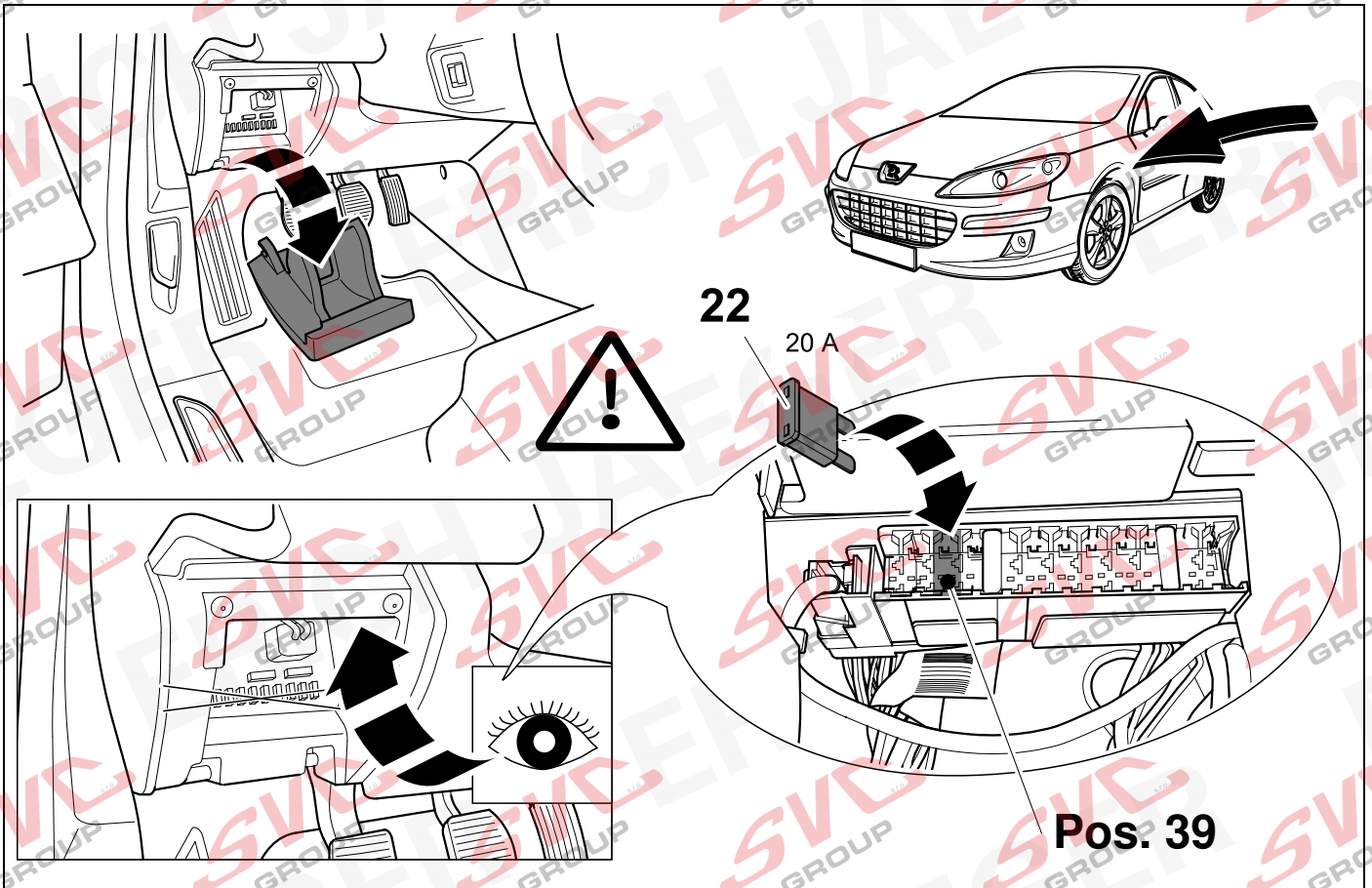

60



78

407 / 407 SW 10/08 >>

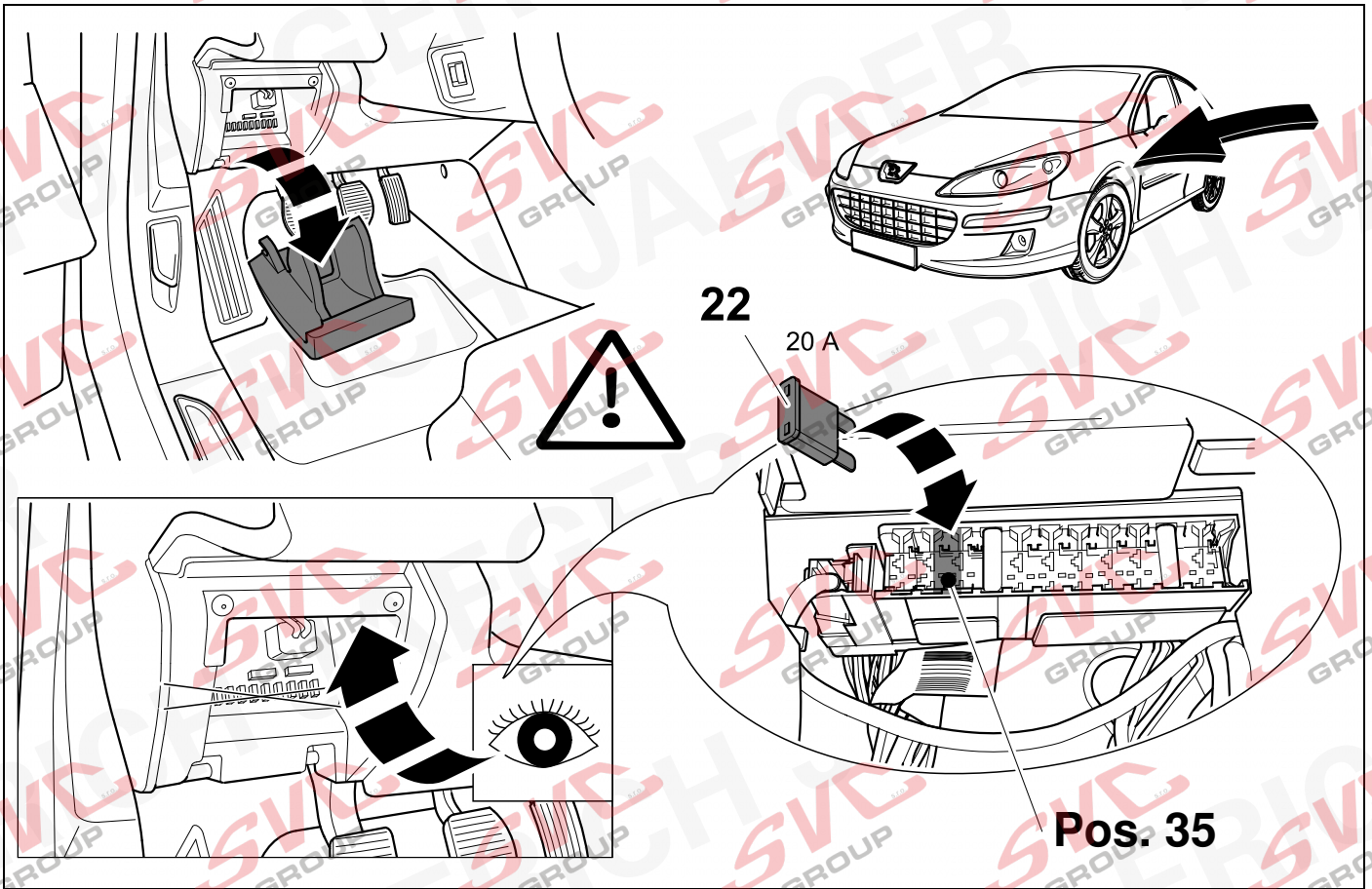

61

407 Coupé

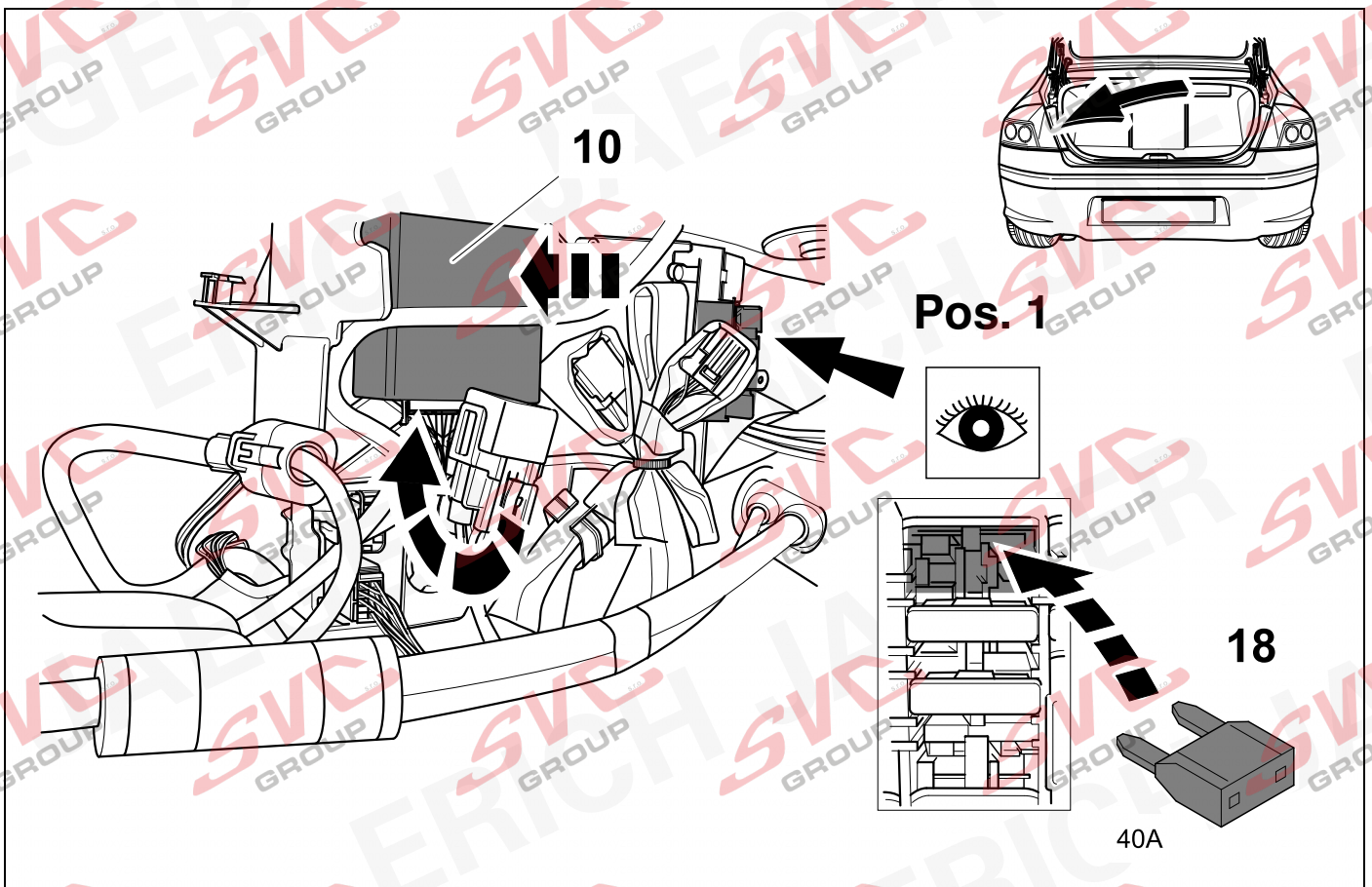



62

407

407 Coupé

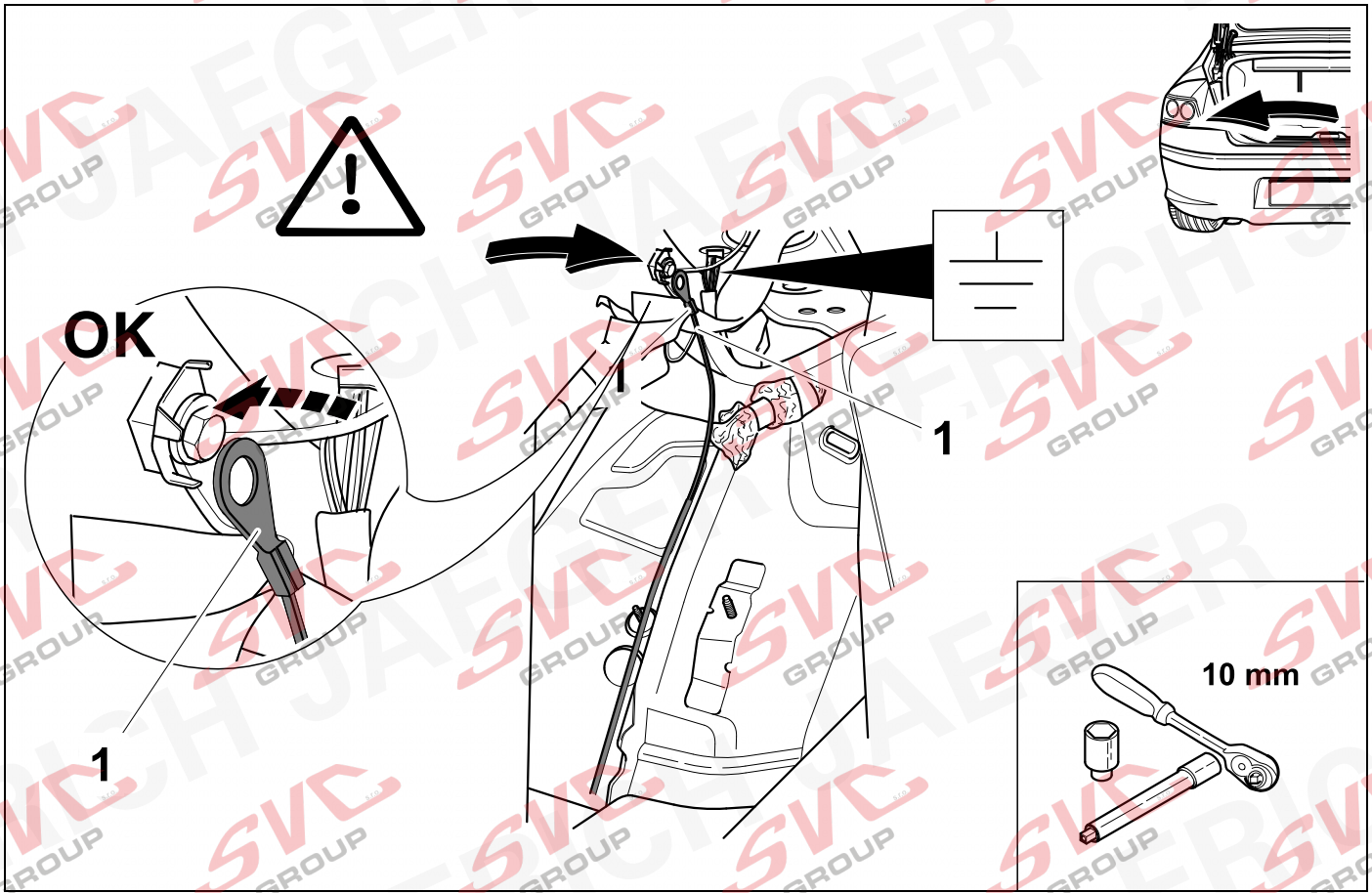

63

407 SW

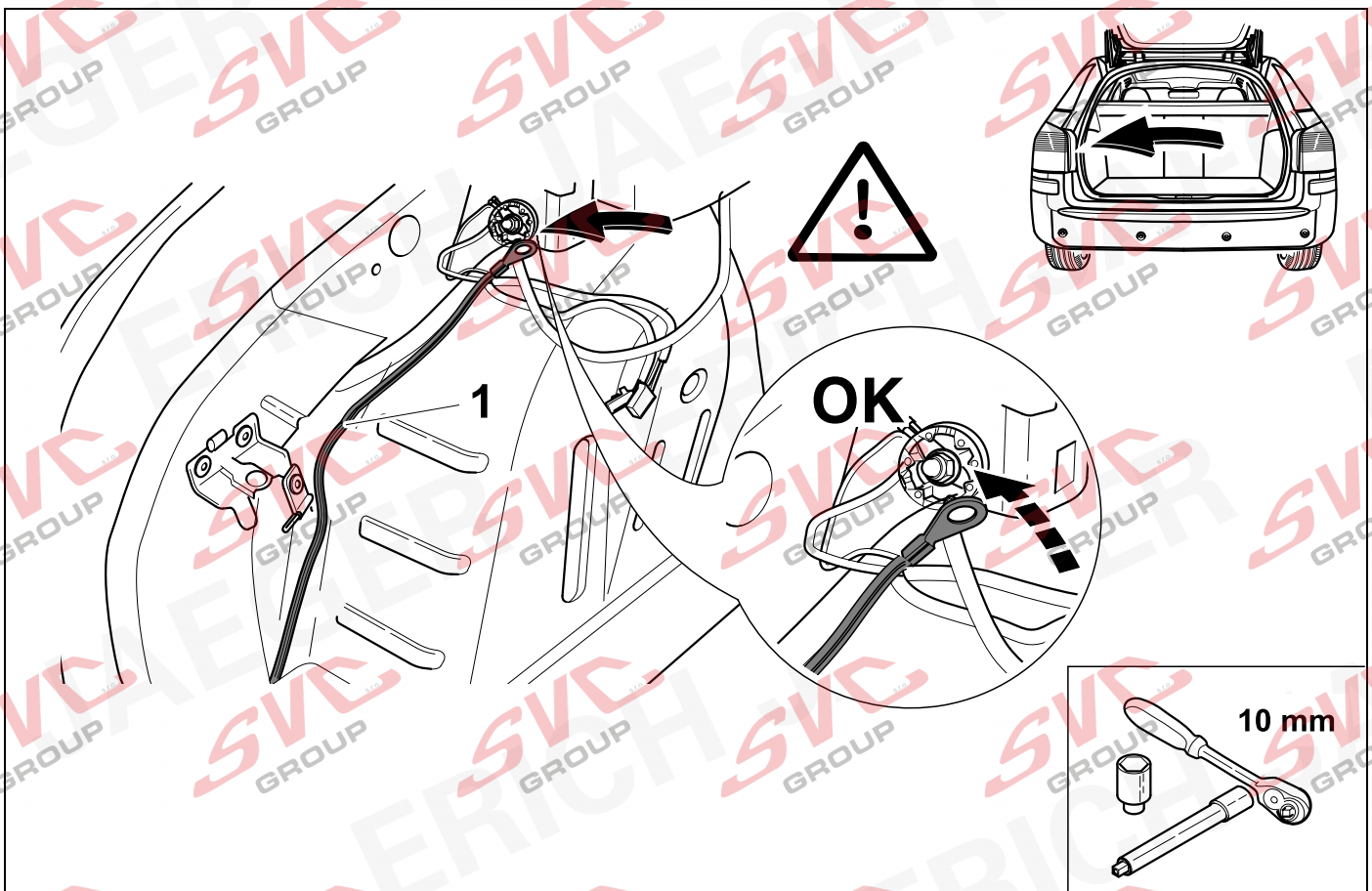

64

Expert

Jumpy

Scudo

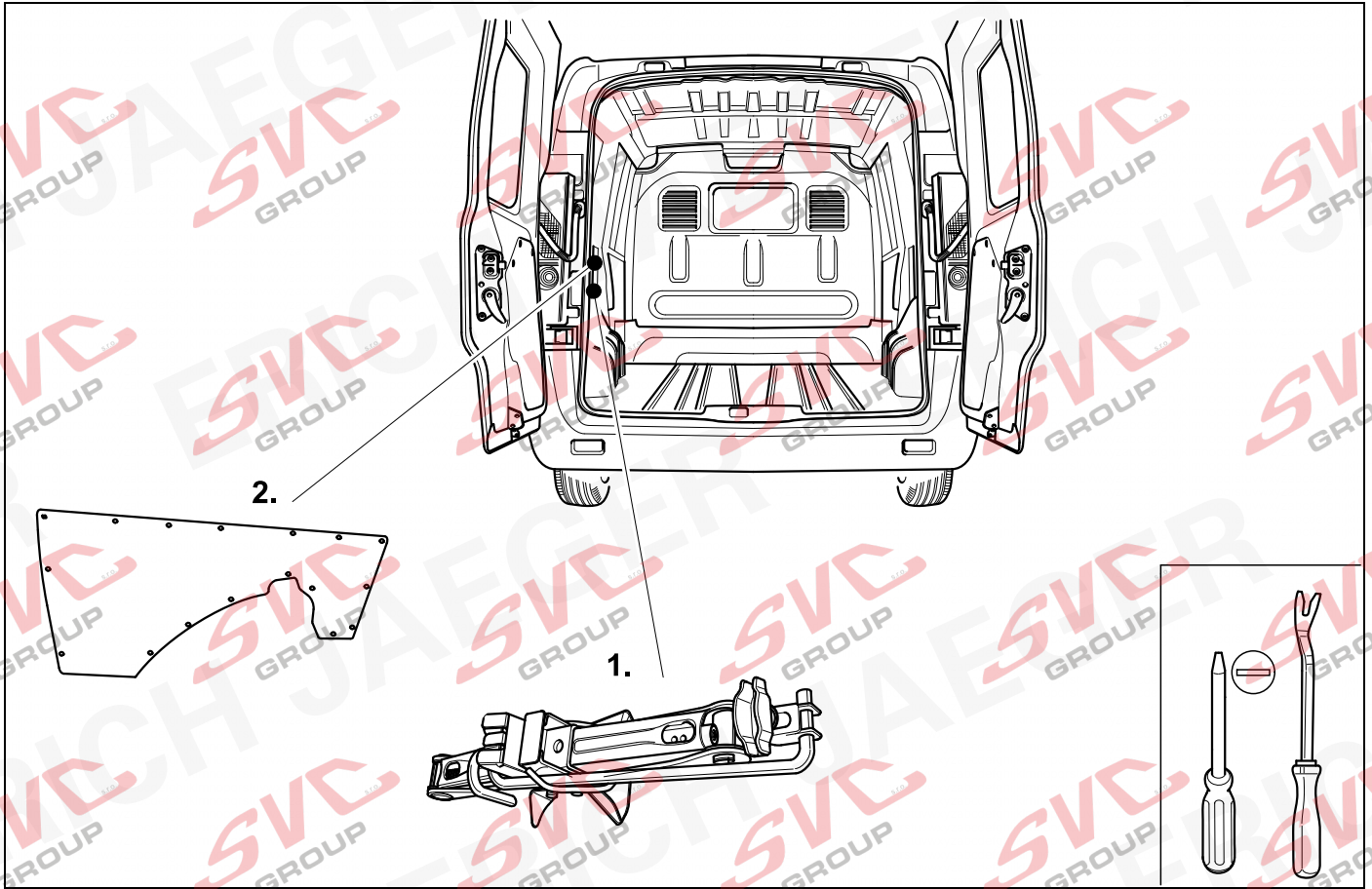

65

Expert

Jumpy

Scudo

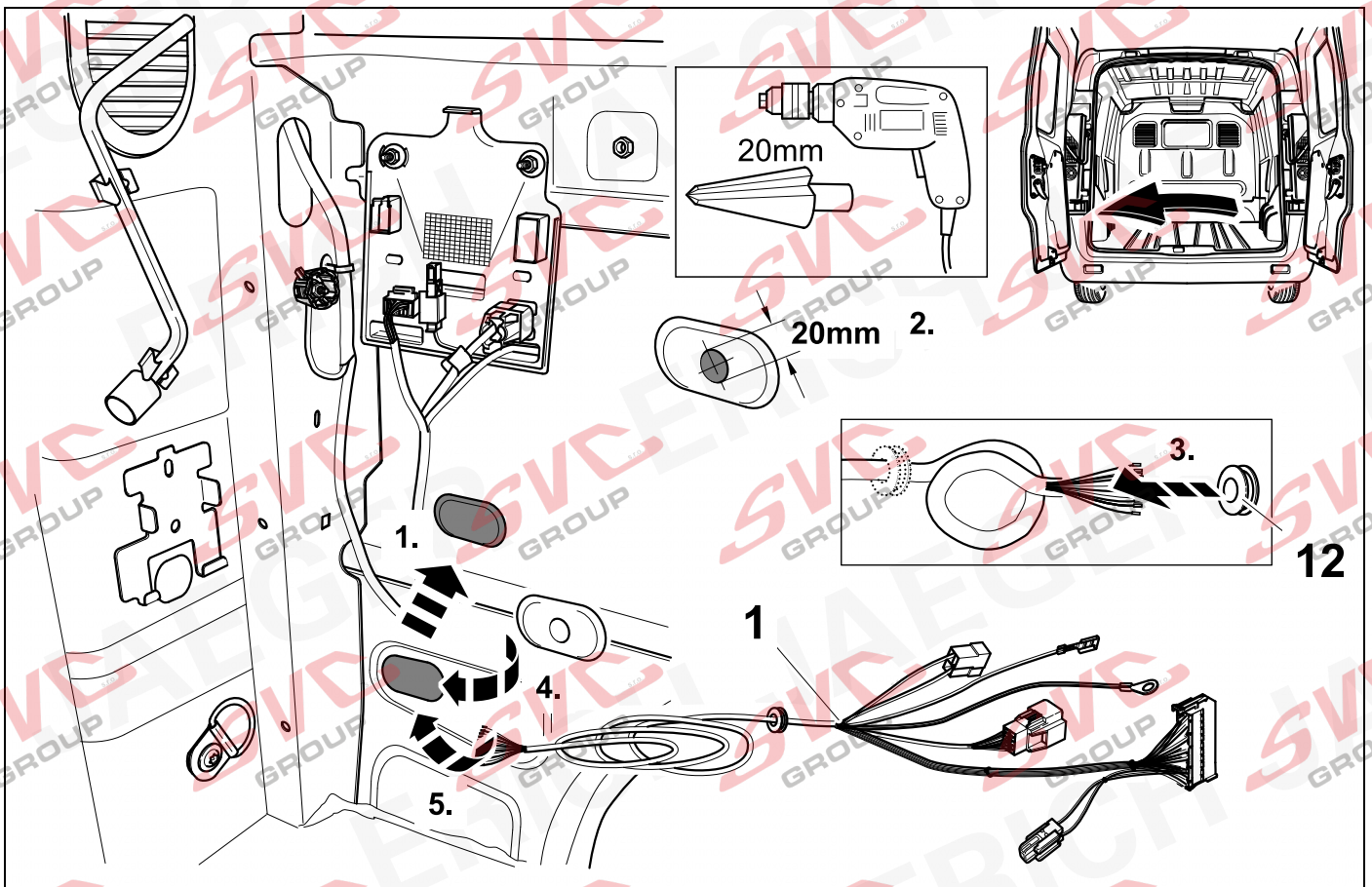

66

Expert

Jumpy

Scudo

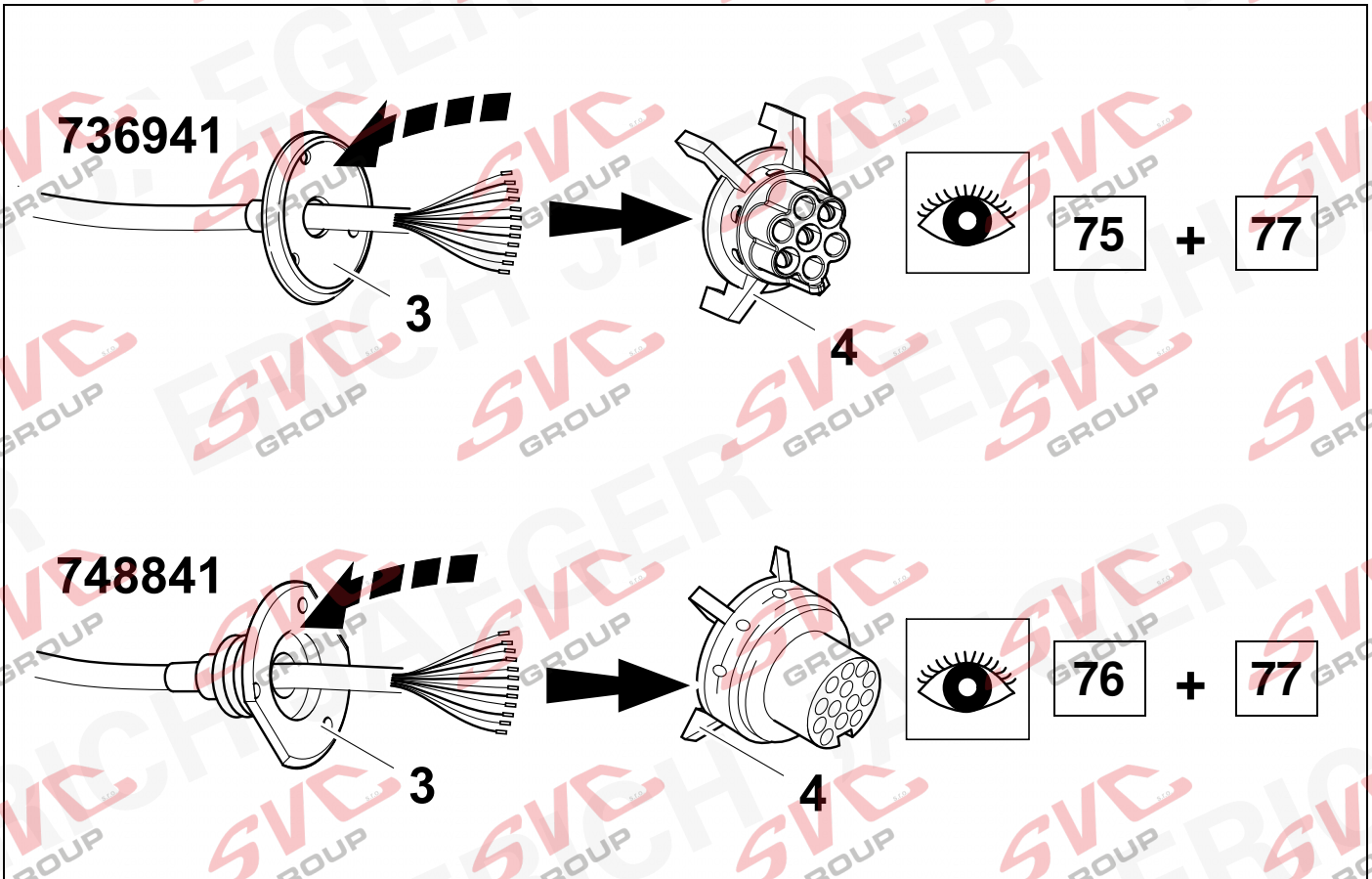

67

Expert

Jumpy

Scudo

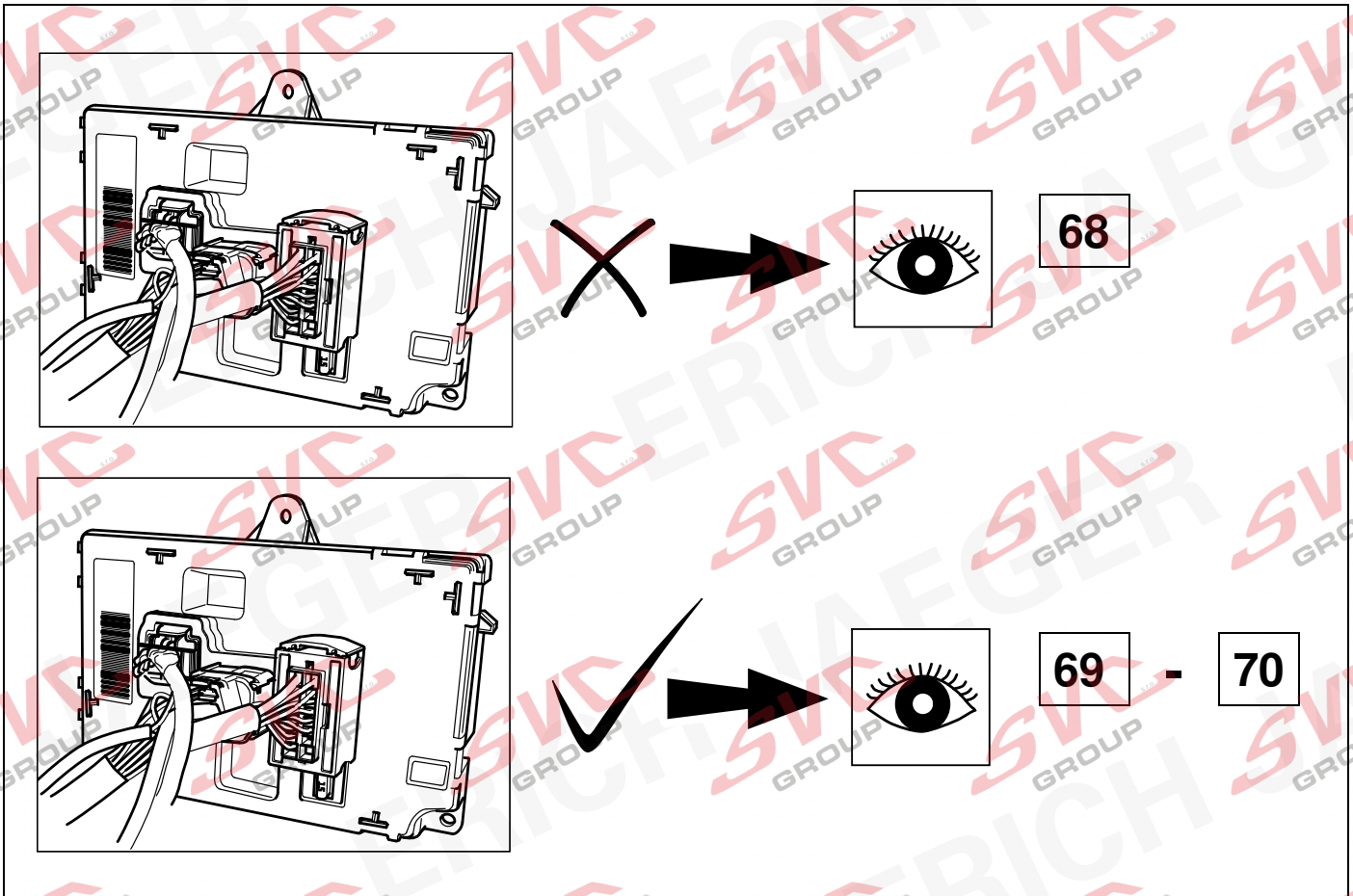

68

Expert



74

Jumpy / Scudo

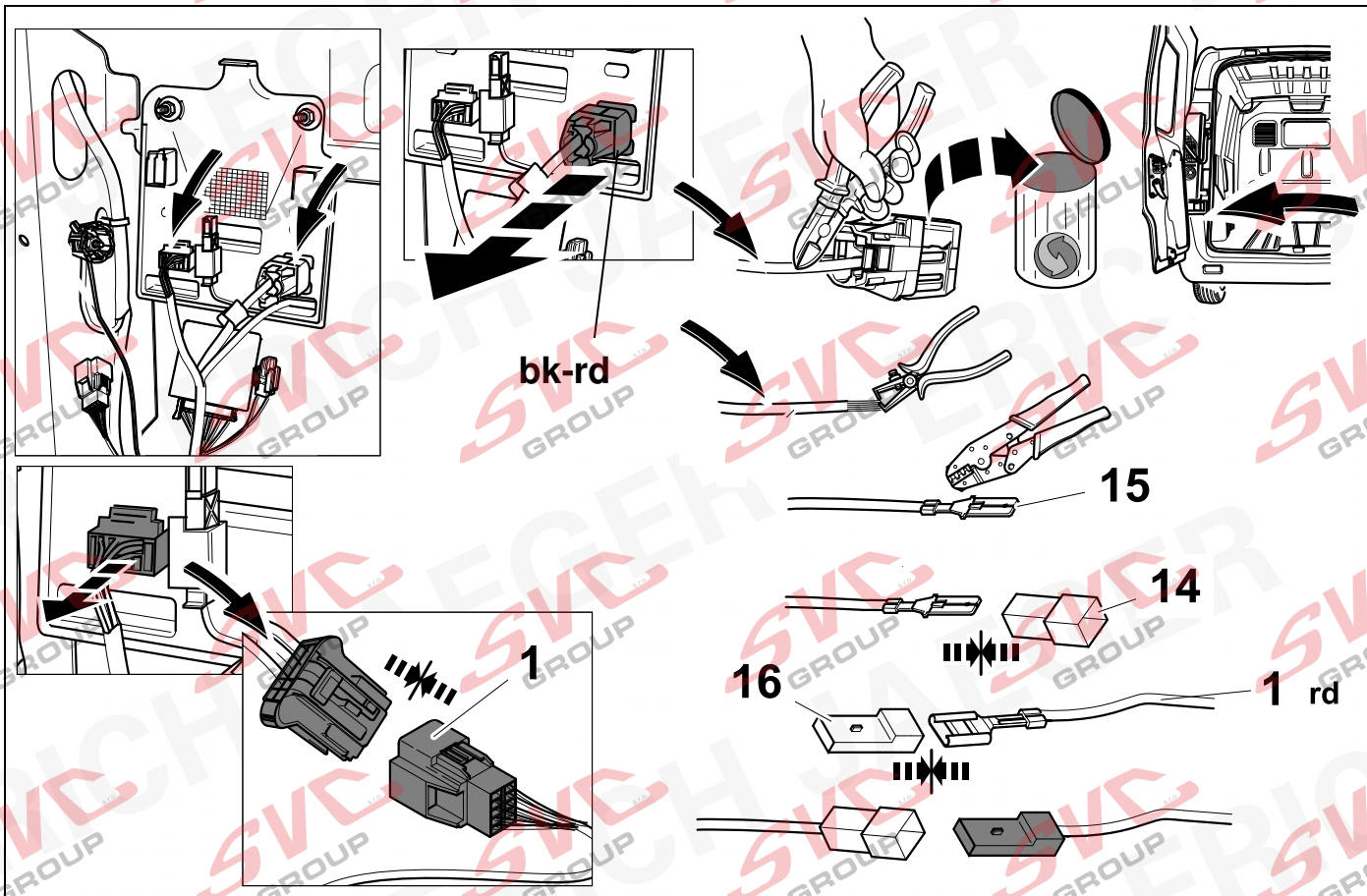

69

Expert



74

Jumpy / Scudo

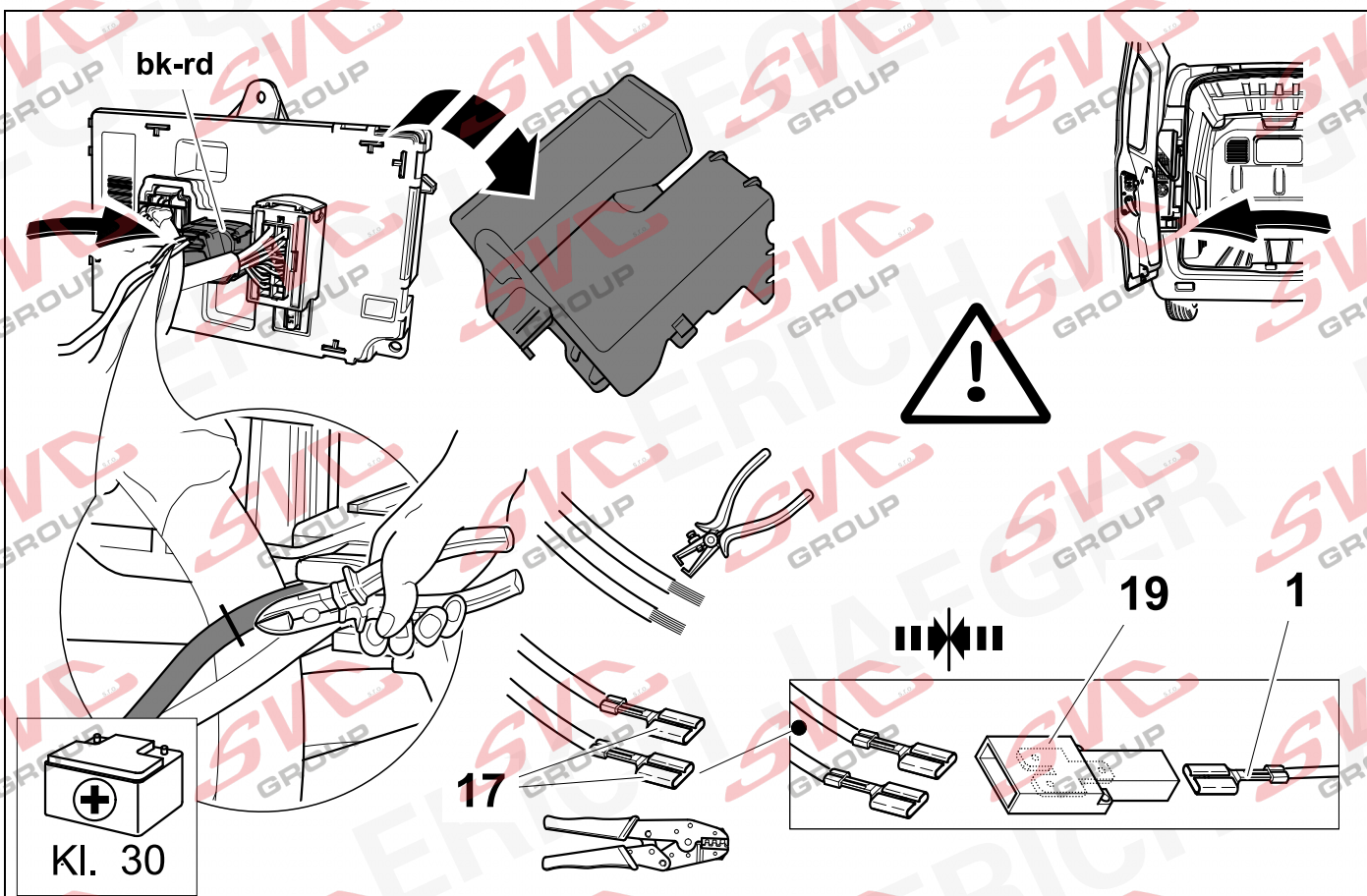

70

Expert

Jumpy

Scudo

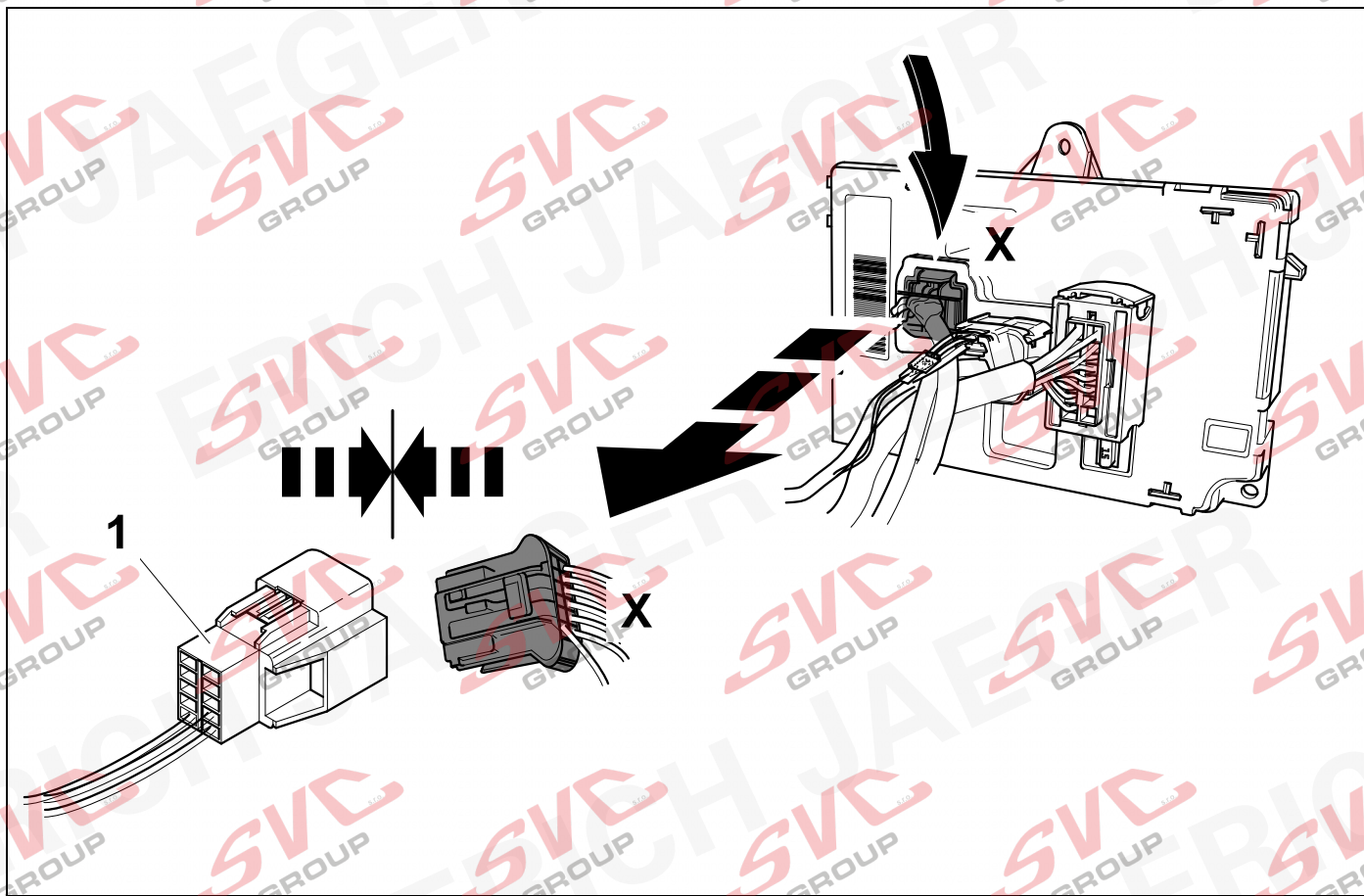

71

Expert

Jumpy

Scudo

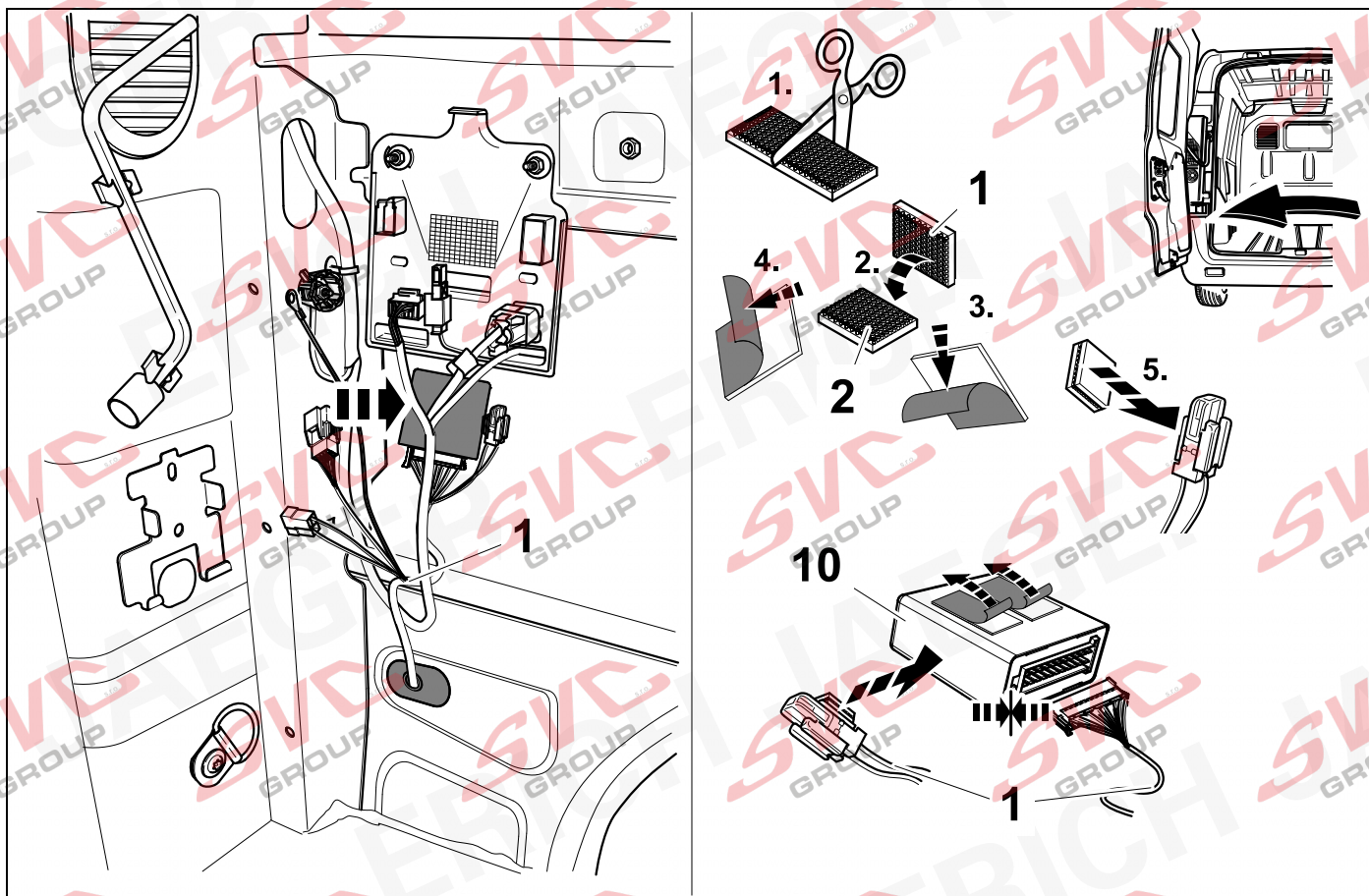

72

Expert

Jumpy

Scudo

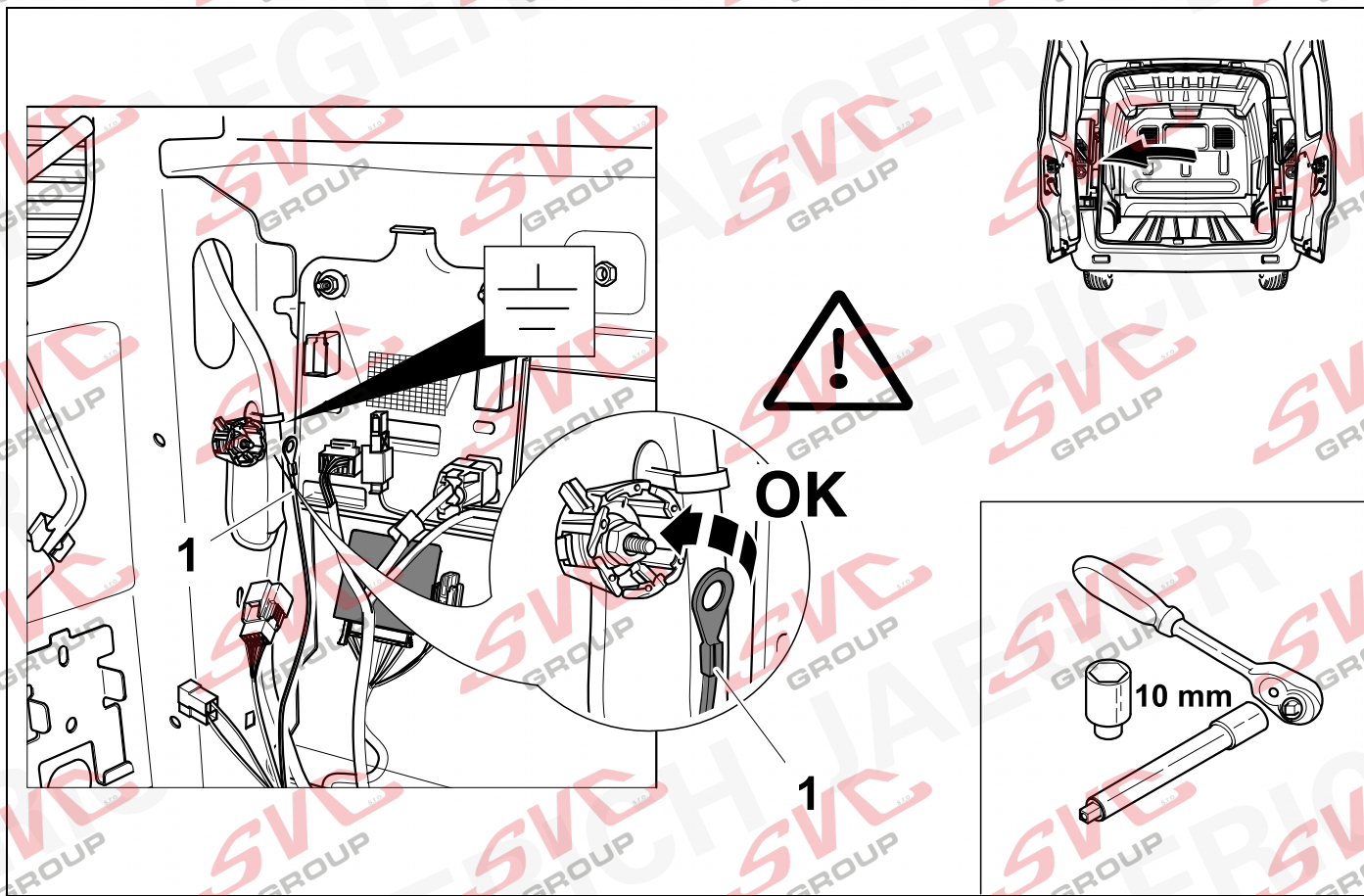

73

Expert

Jumpy

Scudo

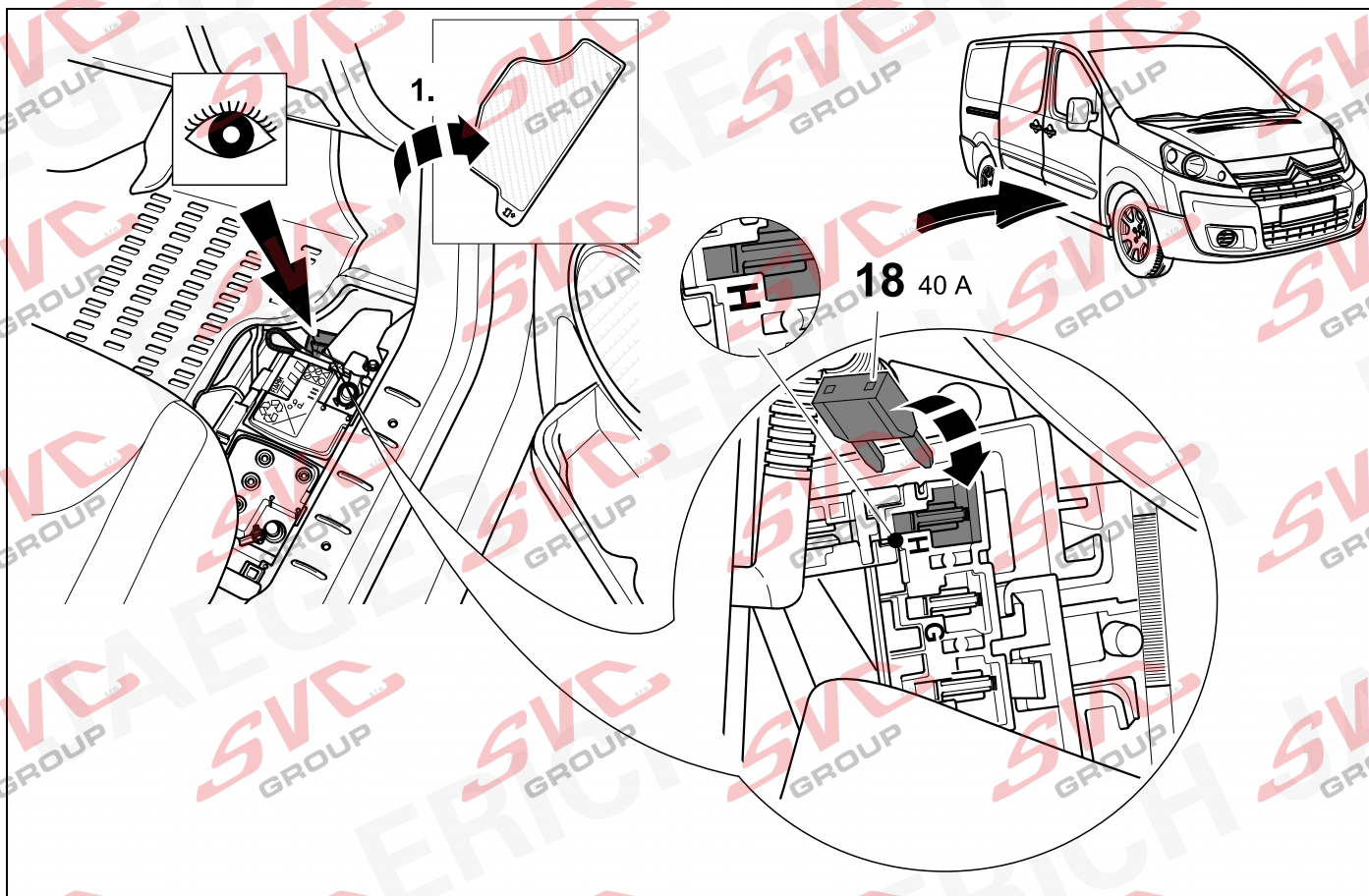

74

736941

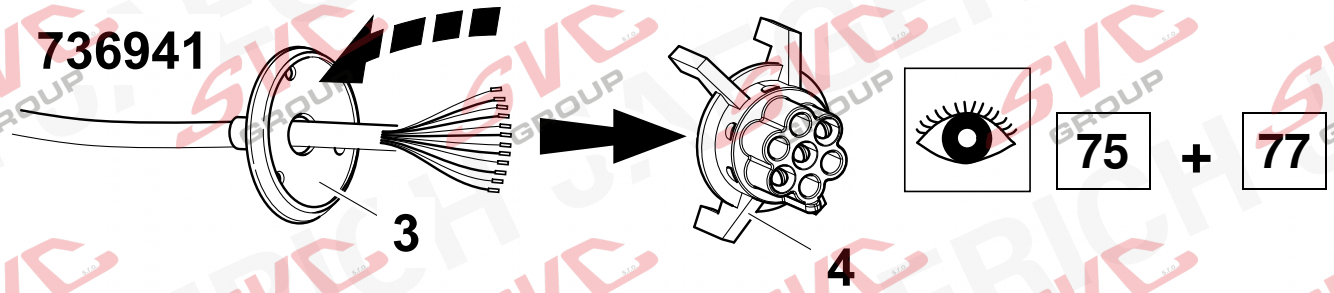

748841

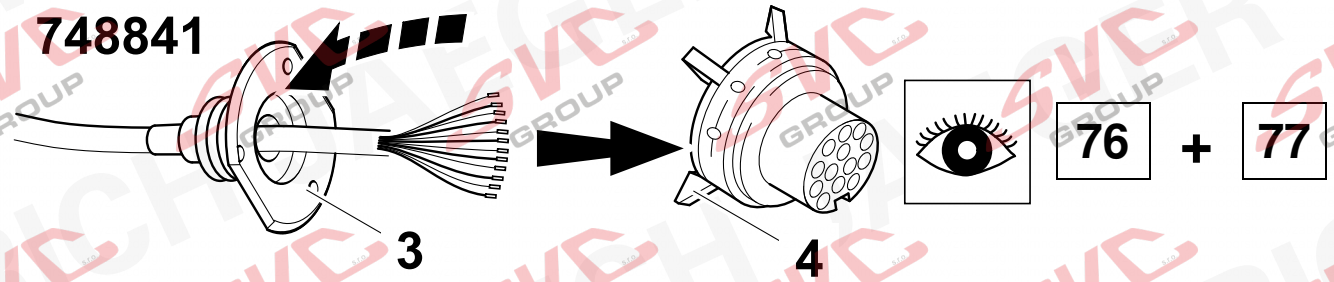

75



73

736941

6

1

4

3

2

5

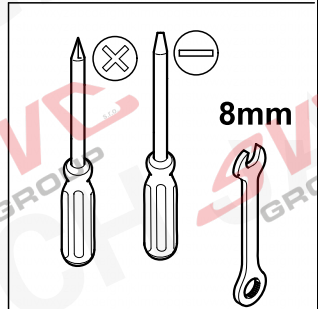
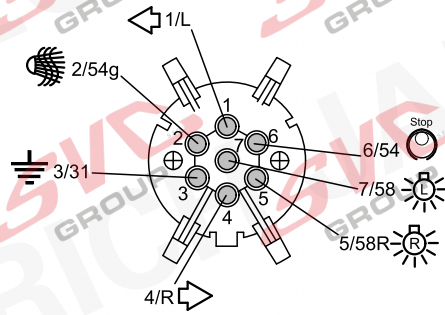

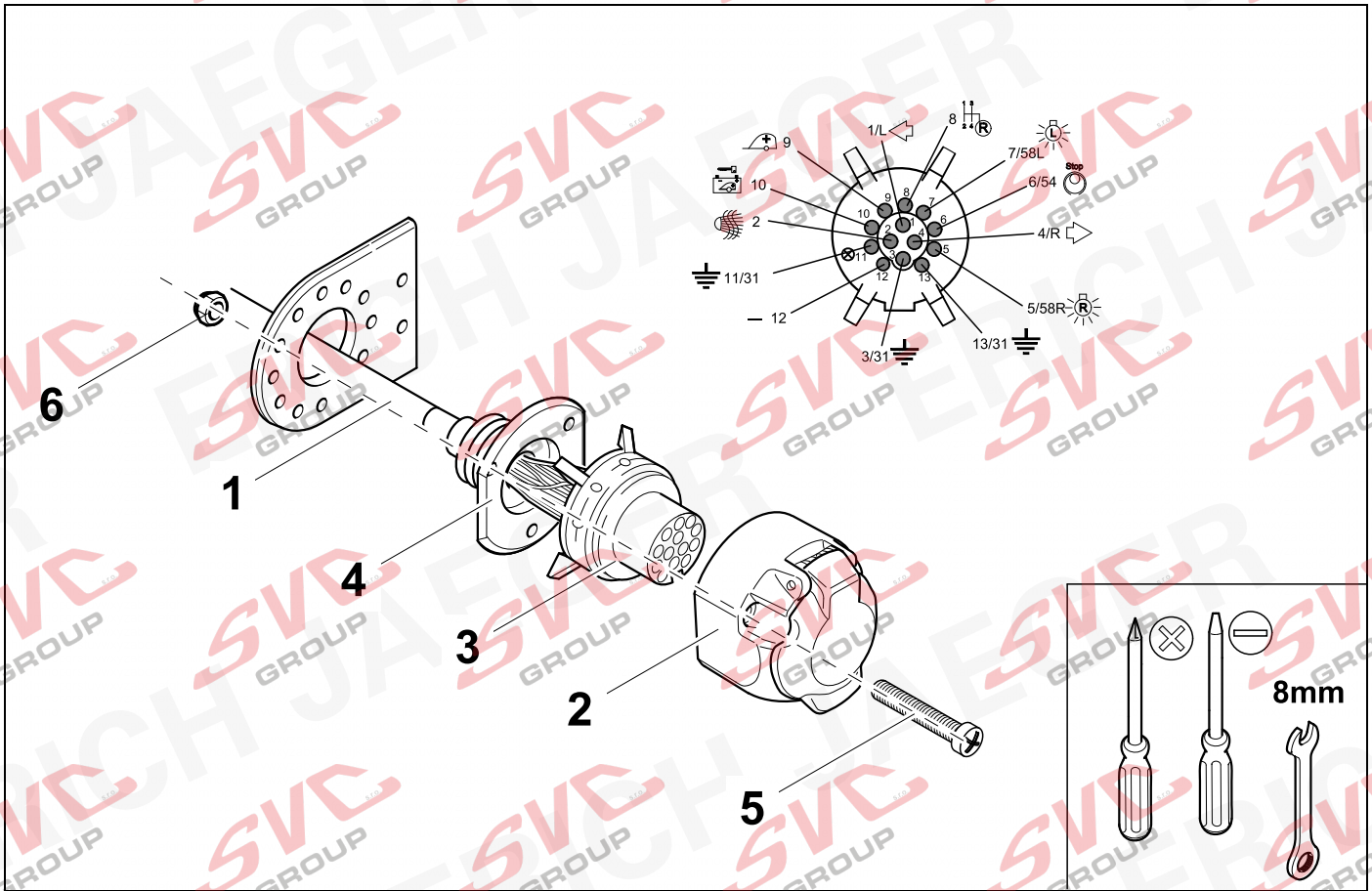



77



78

7 + 13 Pin			13 Pin		
1	bk/wh		8	bu/rd	
2	gy		9	rd/bu	
3	wh/bn		10	no	
4	bk/gn		11	no	
5	gy/rd		12	no	
6	bk/rd		13	bn	
7	gy/bk				

78	bk	wh	gy	gn	rd	bu	ye	bn	pu	or	no
(D)	schwarz	weiss	grau	grün	rot	blau	gelb	braun	violett	orange	nicht belegt
(GB)	black	white	grey	green	red	blue	yellow	brown	purple	orange	not occupied
(F)	noir	blanc	gris	vert	rouge	bleu	jaune	brun	violet	orange	inutilisé
(NL)	zwart	wit	grijs	groen	rood	blauw	geel	bruin	violet	oranje	niet aangesloten
(DK)	sort	hvid	grå	grøn	rød	blå	gul	brun	violet	orange	ikke anvendt
(N)	svart	hvit	grå	grønn	rød	blå	gul	brun	fiolett	oransje	ikke i bruk
(S)	svart	vit	grå	grön	röd	blå	gul	brun	violett	orange	ej använd
(FIN)	musta	valkoinen	harmaa	vihreä	punainen	sininen	keltainen	ruskea	violetti	oranssi	ei varattu
(I)	nero	bianco	grigio	verde	rosso	blu	giallo	marrone	viola	arancione	libero
(E)	negro	blanco	gris	verde	rojo	azul	amarillo	marrón	violeta	anaranja-do	no ocupado
(P)	preto	branco	cinzento	verde	vermelho	azul	amarelo	castanho	violeta	laranja	não ocupado
(GR)	μαύρος	λευκός	Γκρι	πράσινος	κόκκινος	μπλε	κίτρινος	καφέ	Μωβ	πορτοκαλί	δεν είναι κατειλημμένος
(CZ)	černý	bílý	šedý	zelený	červený	modrý	žlutý	hnědý	fialový	oranžový	neobsazen
(TR)	siyah	beyaz	gri	yeşil	kırmızı	mavi	sarı	kahverengi	mor	portakal rengi	boş
(H)	fekete	fehér	szürke	zöld	piros	kék	sárga	barna	ibolyakék	narancssárga	ném foglalt
(HR)	crno	bijelo	sivo	zeleno	crveno	plavo	zuto	smeđe	ljubičasto	narandasto	nije zauzeto
(BUL)	черен	бял	сив	зелен	червен	син	жълт	кафяв	виолетов	оранжев	свободно
(RO)	negru	alb	gri	verde	roșu	albastru	galben	maro	violet	portocaliu	liber
(RU)	черный	белый	серый	зеленый	красный	голубой	желтый	коричневый	пурпурный	оранжевый	свободно
(LT)	juoda	balta	pilka	žalia	raudona	mėlyna	geltona	ruda	purpurinė	oranžinė	laisva
(LV)	melna	balta	pelēka	zaļa	sarkana	zila	dzeltena	brūna	purpur-sarkana	oranža	brīvs
(EST)	must	valge	hall	roheline	punane	sinine	kollane	pruun	purpur-punane	oraanž	vaba
(SLO)	črna	bela	siva	zelena	rdeča	modra	rumena	smeđ	vijoličast	oranžen	ni zasedeno
(SK)	čierny	biely	šedý	zelený	červený	modrý	žltý	hnedý	fialový	pomarančový	neobsadený
(PL)	czarny	biały	szary	zielony	czerwony	niebiesko	żółty	brazowy	fioletowy	pomaran-czowy	wolny

79

748841

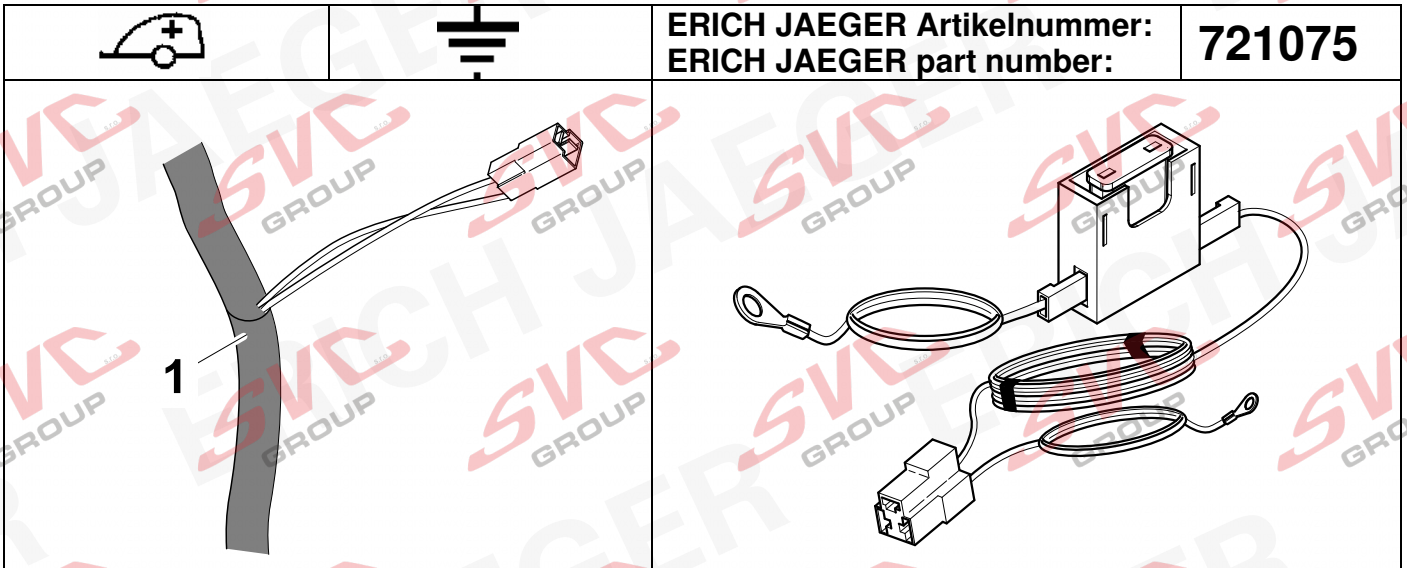

80

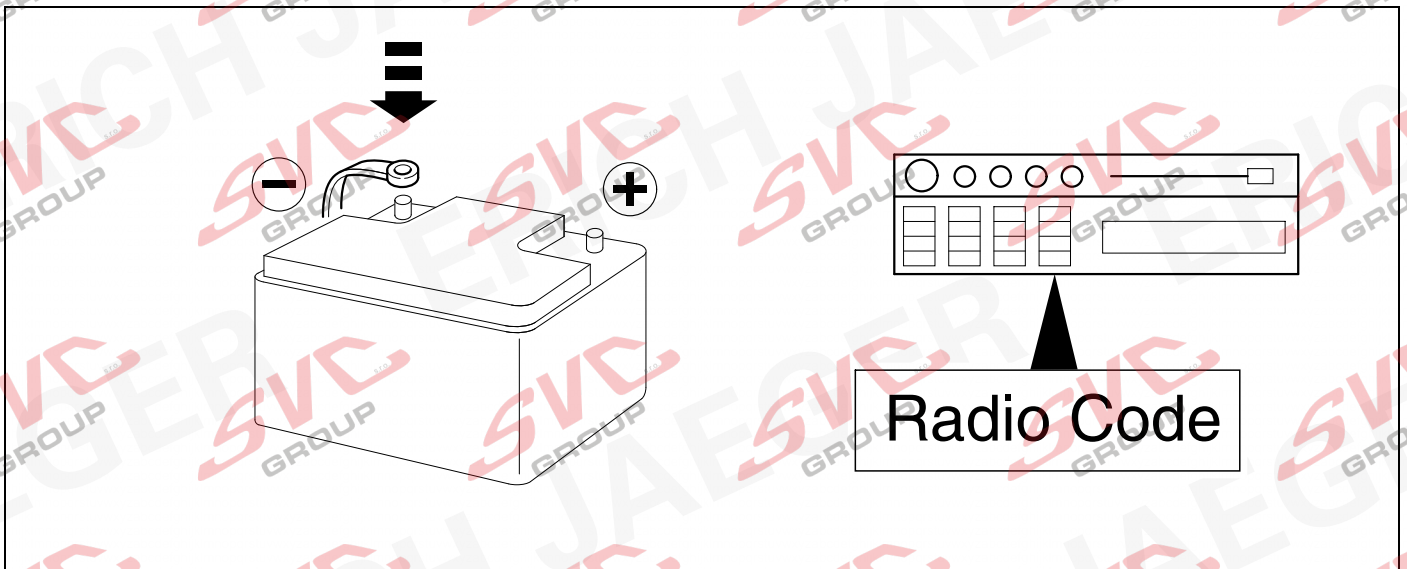

81

- |                               |                                |
|-------------------------------|--------------------------------|
| (D) Funktionen kontrollieren! | (PL) Sprawdź działanie!        |
| (GB) Check functions!         | (TR) İşlevleri kontrol edin!   |
| (F) Contrôler les fonctions!  | (H) Ellenőrizze a funkciókat!  |
| (NL) Controleer functies!     | (HR) Kontrolirati funkcije!    |
| (DK) Kontrollér funktionerne! | (BUL) Проверете функциите!     |
| (N) Kontrollér funksjonene!   | (RO) Controlați funcțiile!     |
| (S) Kontrollera funktionerna! | (RU) Проверить функции!        |
| (FIN) Tarkista toiminnot!     | (LT) Patikrinti funkcijas!     |
| (I) Controllare le funzioni!  | (LV) Pārbaudīt funkcijas!      |
| (E) Compruebe las funciones!  | (EST) Kontrollida funktsioone! |
| (P) Verifique as funções!     | (SLO) Preverite delovanje!     |
| (GR) Ελέγξτε τις λειτουργίες! | (SK) Skontrolovat' funkcie!    |
| (CZ) Zkontrolujte funkce!     |                                |

82

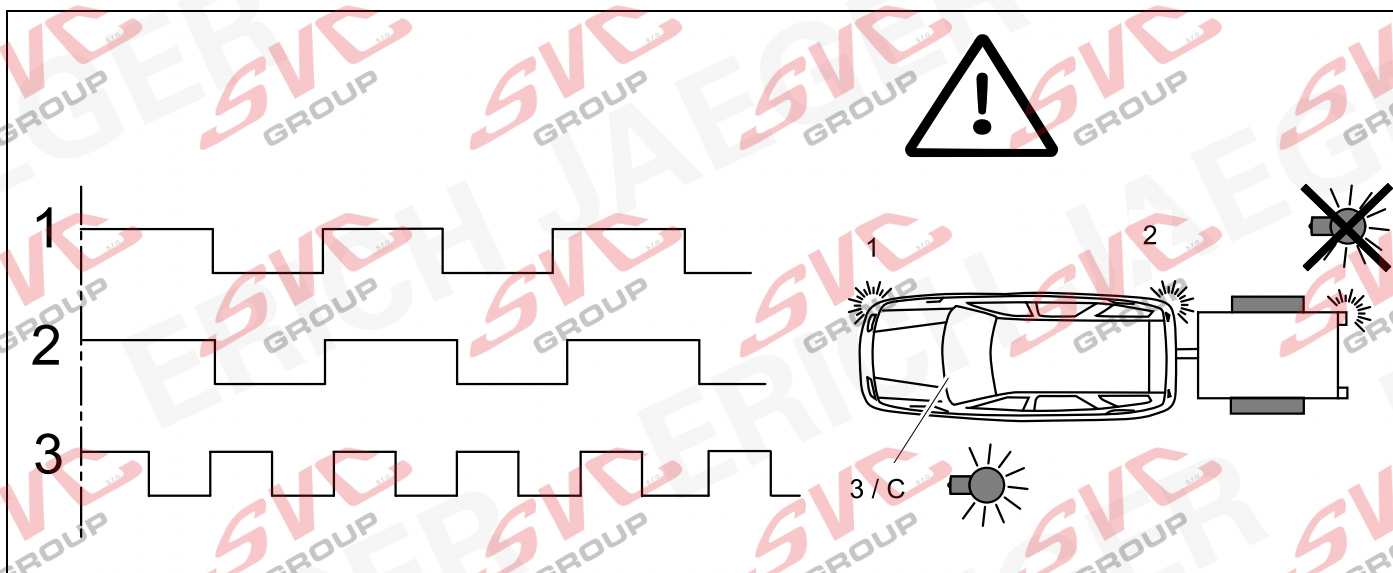

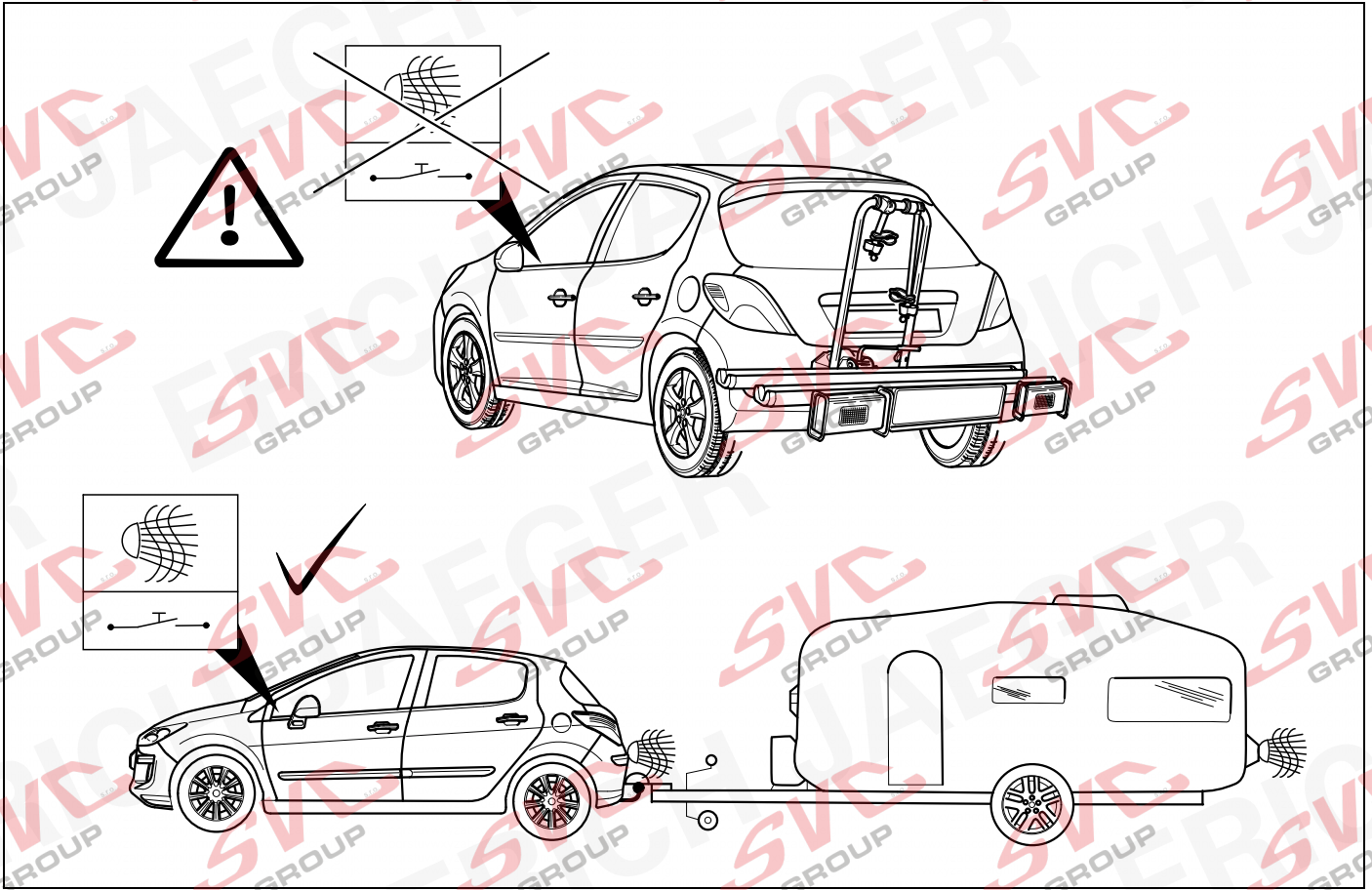

**Erweiterungssatz zur Nebelschlusslichtabschaltung**  
**Extension set for rear fog light cut-off**

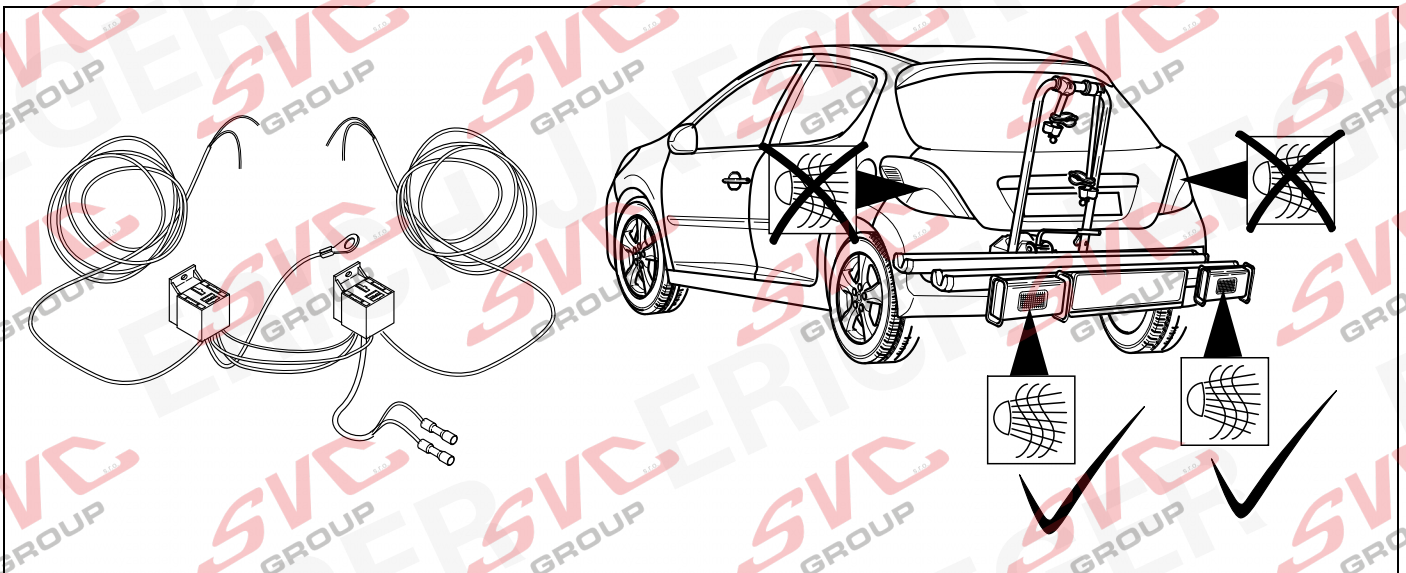



2x 11

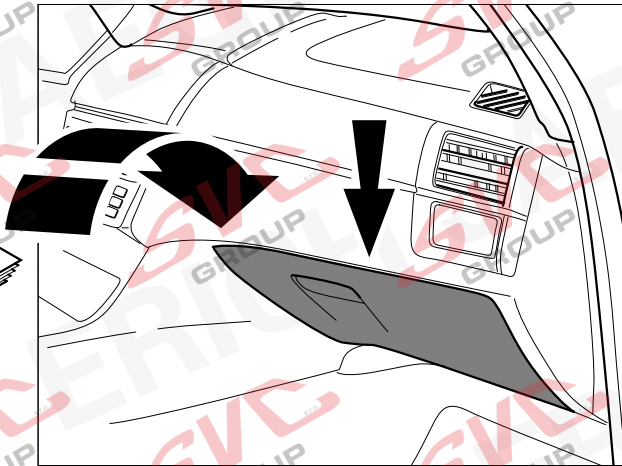
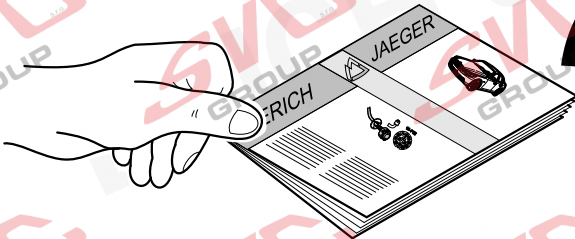
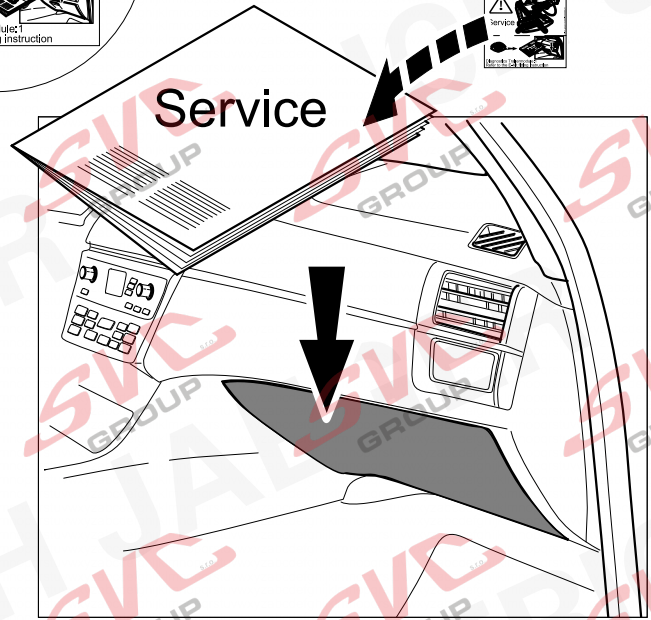
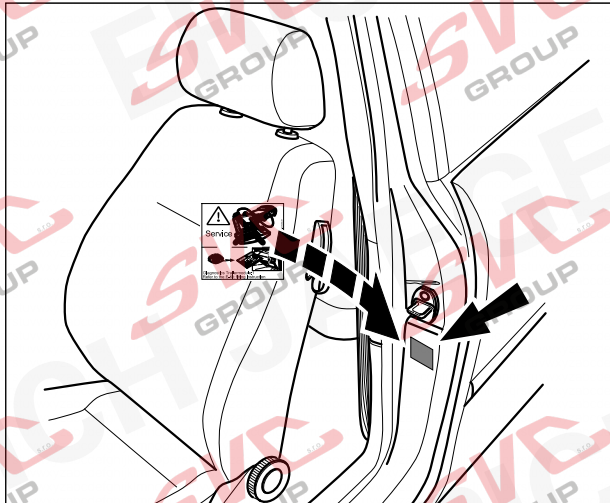
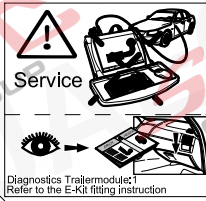









<b>D</b>	Änderungen bezüglich Konstruktion, Ausstattung Farbe sowie Irrtum vorbehalten. Angaben und Abbildungen unverbindlich	<b>PL</b>	Zastrzega się prawo do zmian dot. konstrukcji, wykończenia, kolorystyki oraz pomyłek. Dane i ilustracje niewiążące.
<b>GB</b>	Subject to change in terms of construction, equipment and colour, and may contain errors. The information and illustrations are non-binding.	<b>TR</b>	Tasarım, donanım ve renk bakımından değişiklik yapma hakkı ve hata ve eksiklik mahfuzdur. Veriler ve resimler bağlayıcı değildir.
<b>F</b>	ous réserve de modifications de la construction, de équipement, de la couleur et sous réserve d'erreurs. Les indications et les illustrations sont sans engagement.	<b>H</b>	A szerkezet, a kivitelt és a szín változtatása, valamint a változások joga fenntartva. Az adatok és az ábrák nem kötelező érvényűek.
<b>NL</b>	Wijzigingen met betrekking tot constructie, uitvoering en kleur evenals vergissingen voorbehouden. Gegevens en afbeeldingen niet bindend.	<b>HR</b>	Pravo promjena u svezi konstrukcije, opreme, boje kao i zabune oridžavamo. Podaci i ilustracije su neobavezne.
<b>DK</b>	Ændringer med hensyn til konstruktion, udstyr, farver samt fejl forbeholdes. Oplysninger og illustrationer er uforpligtende.	<b>BUL</b>	Запазени права по отношение на конструкцията, обзавеждането, цвета и грешки. Данните и изображенията не са обвързващи.
<b>N</b>	Ændringer angående konstruksjon, utstyr, farge og feiltagelse forbeholdes. Oplysninger og illustrasjoner uforbindtlig.	<b>RO</b>	Ne rezervăm dreptul unor modificări ale construcției, dotării, culorii și dreptul la erori Datele indicate și imaginile sunt orientative.
<b>S</b>	Med reservation för ändringar vad det gäller konstruktion, utrustning, färg samt för misstag. Uppgifterna och bilderna är inte bindande.	<b>RU</b>	Права на внесение изменений относительно конструкции, оснащения, окраски, а также на ошибки сохраняются. Данные и иллюстрации имеют примерный характер.
<b>FIN</b>	Pidätämme oikeuden rakennetta, varustusta, väriä koskeviin sekä erehdyksestä johtuviin muutoksiin. Tiedot ja kuvat eivät ole sitovia.	<b>LT</b>	Pasilikama konstrukcijos, įrangos bei reikmenų, spalvos pakeitimų ir klaidų teisė. Duomenys ir iliustracijos neįpareigojantys.
<b>I</b>	Con riserva di modifiche relative a progettazione, dotazione, colore ed errori. Le indicazioni e figure sono fornite senza impegno.	<b>LV</b>	Tiek paturētas tiesības uz konstrukcijas, iekārtu, krāsu izmaiņām, kā arī kļūdišanās. Dati un attēli bez saistībām.
<b>E</b>	Reservadas las modificaciones respecto a diseño, equipamiento, color, así como error. Indicaciones y figuras sin compromiso.	<b>EST</b>	Konstruktsiooni, varustuse ja värvi osas muudatused ning eksimine lubatud. Andmed ja joonised on mittesiduvad.
<b>P</b>	Reservamos o direito de alterações relativamente ao desenho, equipamento, cor, bem como de erro. Os dados e as gravuras não implicam compromisso da nossa parte.	<b>SLO</b>	Zadržana pravica do sprememb glede konstrukcije, opreme, barve ter pomote. Podatki in slike so neobvezne.
<b>GR</b>	Διατηρώνουμε κάθε επιφύλαξη ως προς αλλαγές σε σχέση με κατασκευή, εξοπλισμό, διαρρύθμιση, χρωματισμούς και λάθη παραδρομής.	<b>SK</b>	Zmeny, ktoré sa týkajú konštrukcie, vybavenia, farby, ako aj omyly sú vyhradené. Údaje a zobrazenia sú nezáväznú. pl
<b>CZ</b>	Změny, týkající se konstrukce, vybavení, barvy, jakož i omyly jsou vyhrazeny. Údaje a vyobrazení jsou nezávazné.		

**ERICH JAEGER Artikelnummer: 311069**  
**ERICH JAEGER part number:**

**ERICH JAEGER Artikelnummer: 311105**  
**ERICH JAEGER part number:**

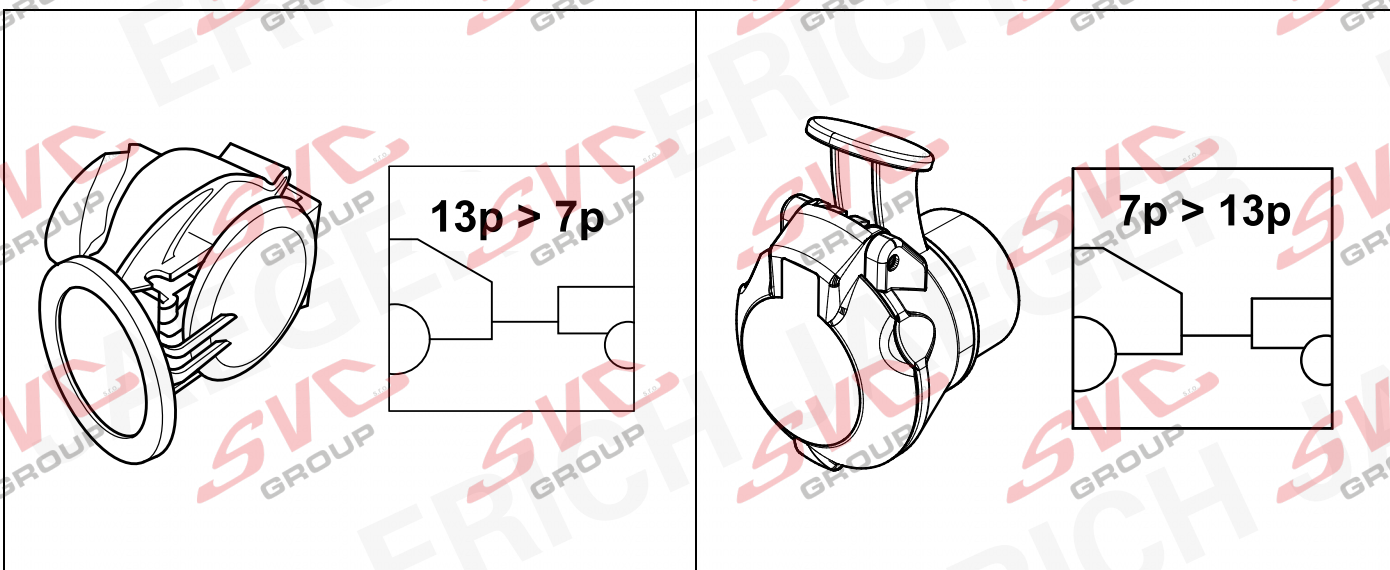

Nevíte si rady? Potřebujete poradit?

# Náš zákaznický servis je vám k dispozici

 +420 491 421 021

 [svc@svcgroup.cz](mailto:svc@svcgroup.cz)



Opravdový specialista a Certifikovaný výrobce tažných zařízení s největším sortimentem v ČR. Rodinná firma s více jak 30letou ověřenou tradicí výroby, prodeje a montáže.

[www.svcgroup.cz](http://www.svcgroup.cz)